

"innovation in its most functional form"

PRODUCT DATA SHEET

SW9TM

MECHANICAL FLANGE

SPREADER

SPREADING FORCE:

150 ft/lbs (203 N/m) = 9.4 T (94 kN)

It is recommended that tools are used in pairs giving
 $2 \times 9.4 = 18.8 \text{ T (188 kN)}$

TOOL WEIGHT = 5.5kg (12.13 lbs)

KIT COMPONENTS

- 1 x SW9TM Wedgehead
- 1 x 150 ft/lbs (203 N/m) Torque Wrench with 22mm socket
- 1 x Safety Block
- 1 x Instruction Manual
- 1 x Cardboard Packaging
- Product Code: SW90TMMIN



WEIGHTS AND DIMENSIONS

Tool Weight	= 5.5 kg (12.13 lb)	Packaging Dimensions:
Torque Wrench	= 1.5 kg (3.31 lb)	190 x 180 x 320mm (7.48" x 7.09" x 12.60")
Safety Block	= 0.5 kg (1.10 lb)	
Gross Weight	= 7.5 kg (16.53 lb)	

TOOL DIMENSIONS - CLOSED

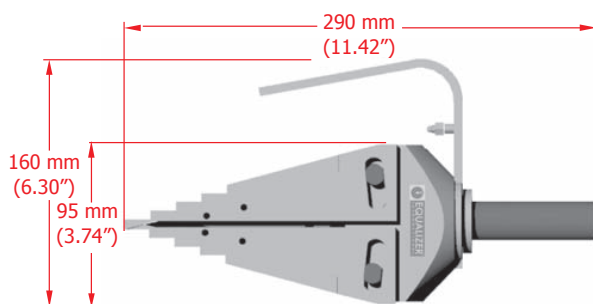

TOOL DIMENSIONS - OPEN

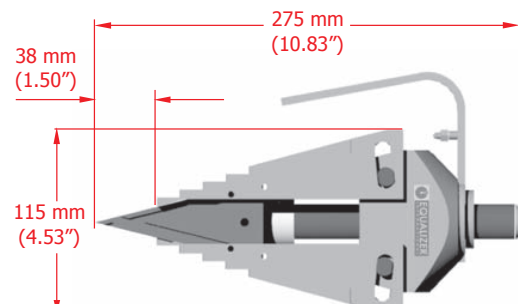

TOOL DIMENSIONS - CLOSED

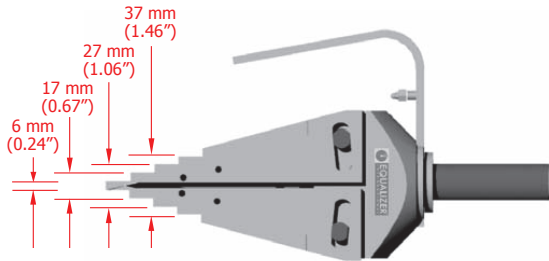

TOOL DIMENSIONS - OPEN

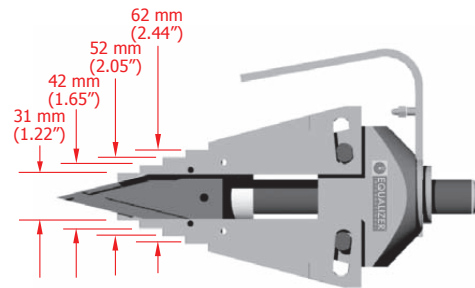

SAFETY BLOCK

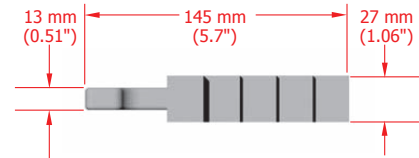
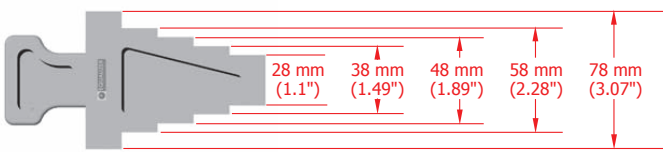

RANGE OF APPLICATION

All flanges with a minimum access gap of 6 mm (0.24")

ITEM	PART No.	DESCRIPTION	QUANTITY
01	060101-01	WHITE PLASTIC CAP	01 each
02		SERIAL NO STICKER	01 each
03		PINCH POINT STICKER	02 each
04		GREASE POINT STICKER	02 each
05		BADGE LOGO	02 each
06		SWL STICKER	02 each
07	300101-01	WEDGE	01 each
08*		M5X6 SCKT SCREW	01 set of 4
09*		SLIDE PIN	01 set of 4
10	301102-01	MAIN BODY	01 each
11	301201-01	SPIROL PIN	01 set of 8
12*		M6X12 GRAB SCREW	01 each
13*		M14 HALF NUT	01 each
14*		BEARING CARRIER	01 each
15	301901-01	M/F ADAPTOR	01 each
16	302001-01	HANDLE	01 each
17	302101-01	EXTERNAL CIRCLIP	01 each
18*		PUSH ROD	01 each
19	310601-01	M6 GREASE NIPPLE	01 each
20	312302-01	HANDLE SLEEVE	01 each
21*		THRUST WASHER	02 each
22*		THRUST RACE	01 each
23	300203-02	FORGED JAW	01 set of 2
24	320901-01	22 MM 1/2" SOCKET	01 each
25	634001-01	TORQUE WRENCH	01 each

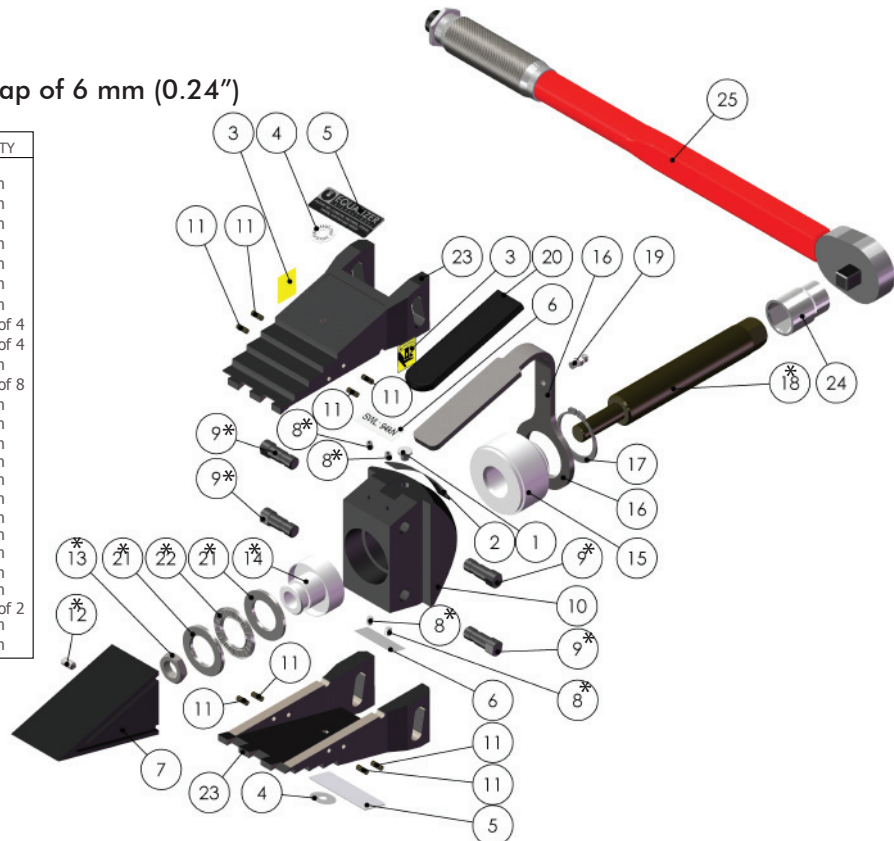

*Items 8, 9, 12, 13, 21 & 22 are supplied in Repair Kit Part No: 310501-01
 *Items 14 & 18 are supplied in Repair Kit Part No: 310502-01

STEPPED BLOCKS

Stepped Blocks can be used singly or in pairs to increase the maximum spreading distance of the SW9TM to 81mm

STEPPED BLOCK KIT (AVAILABLE AS AN OPTION)

KIT COMPONENTS

- 2 x Stepped Blocks
- 2 x M6 x 10 mm Countersunk Screws
- 1 x 4mm Hex Key
- Kit Part No: 303301-01

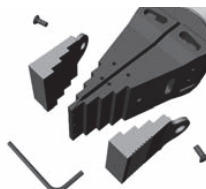

WEIGHTS AND DIMENSIONS

Stepped Block = 0.52 kg (1.14 lb)
 GROSS WEIGHT = 1.5 kg (3.5 lb)

