

SPX Hydraulic Technologies  
5885 11th Street  
Rockford, IL 61109-3699 USA  
[powerteam.com](http://powerteam.com)

Tech. Services: (800) 477-8326  
Fax: (800) 765-8326  
Order Entry: (800) 541-1418  
Fax: (800) 288-7031

### *Electric-Powered* **10 Series Hydraulic Pump**





# Table of Contents

Description . . . . .	2
PE10-Series Electric / Hydraulic Pumps . . . . .	2
Control Valves . . . . .	3
Safety Symbols and Definitions . . . . .	4
Safety Precautions . . . . .	4
Initial Setup . . . . .	8
Operating Instructions . . . . .	12
Performance Specifications . . . . .	13
General Maintenance . . . . .	14
Troubleshooting Guide . . . . .	16
Power Team Facilities . . . . .	19

## Description

The 10 series hydraulic pumps are designed to have a maximum of 690 bar (10,000 psi) at a flow rate of 164 cc/min (10 cu. in./min). A pump can be valved for use with either single- or double-acting cylinders. All pumps come fully assembled, less fluid, and ready for work.

### PE10-Series Electric / Hydraulic Pumps

#### Electric Driven Motor

Motors are available in 0.186 kW (1/4 HP) in three voltages: 110/115VAC, 220/230 VAC, and 12 VDC.



Figure 1. PE10

# Control Valves

Max. Capacity: 690 bar (10,000 psi)

	Valve Function	Use with Cylinder Type	Valve No.
PE102 PE102-220 PR102	<p><b>Advance</b> Pump "ON" Hold Position</p>  <p><b>Return</b> Pump "OFF" Return Position</p> 	Single-acting	9561 2-way/auto dump, advance return (auto)
	<b>Diagrams</b>		
			
PE102A PE102A-220 PR102A	<p><b>Advance</b> Pump "ON"</p>  <p><b>Return</b> Pump "OFF"</p> 	Single-acting	9562 auto dump, advance return
	<b>Diagrams</b>		
			
PE104 PE104-220 PR104	<p><b>Position "A"</b></p>  <p><b>Center Position</b></p>  <p><b>Position "B"</b></p> 	Single- and double-acting	9563 4-way, advance hold return
	<b>Diagrams</b>		
			

Table 1. Pump Configurations

# Safety Symbols and Definitions

The safety signal word designates the degree or level of hazard seriousness.

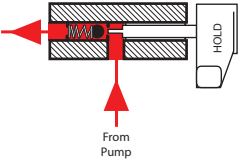
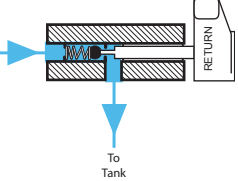
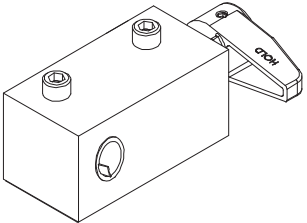
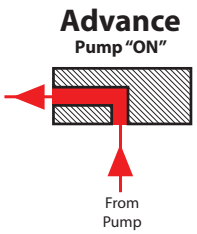
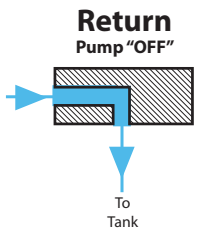
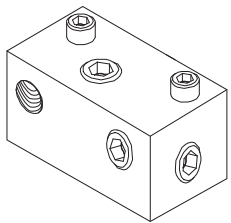
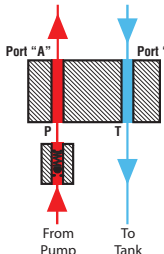
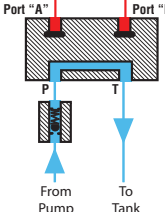
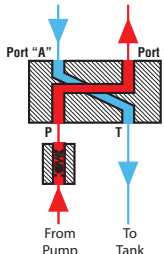
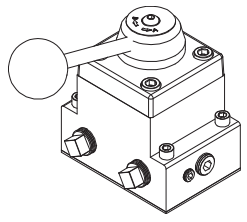

**DANGER:** Indicates an imminently hazardous situation which, if not avoided, will result in death or serious injury.



**WARNING:** Indicates a potentially hazardous situation which, if not avoided, could result in death or serious injury.



**CAUTION:** Indicates a potentially hazardous situation which, if not avoided, may result in minor or moderate injury.

**CAUTION:** Used without the safety alert symbol indicates a potentially hazardous situation which, if not avoided, may result in property damage.

**IMPORTANT:** Important is used when action or lack of action can cause equipment failure, either immediate or over a long period of time.

## Safety Precautions



### WARNING:



- The following procedures must be performed by qualified, trained personnel who are familiar with this equipment. Operators must read and understand all safety precautions and operating instructions included with the pump. If the operator cannot read these instructions, operating instructions and safety precautions must be read and discussed in the operator's native language.

- These products are designed for general use in normal environments. These products are not designed for lifting and moving people, agri-food machinery, certain types of mobile machinery, or in special work environments such as: explosive, flammable, or corrosive. Only the user can decide the suitability of this product in these conditions or extreme environments. Power Team will supply information necessary to help make these decisions. Consult your nearest Power Team facility.



- Safety glasses must be worn at all time by the operator and anyone within sight of the unit. Additional personal protection equipment may include: face shield, goggles, gloves, apron, hard hat, safety shoes, and hearing protection.



- The owner of this tool must ensure that safety-related decals are installed, maintained, and replaced if they become hard to read.



- Shut OFF the motor before opening any connections in the system.
- The guide cannot cover every hazard or situation so always do the job with SAFETY FIRST.

### Pump



### WARNING:

- Do not exceed the hydraulic pressure rating noted on the pump nameplate or tamper with the internal high pressure relief valve. Creating pressure beyond rated capacities can result in personal injury.
- Retract the system before adding fluid to prevent overflowing the pump reservoir. An overflow can cause personal injury due to excess reservoir pressure created when cylinders are retracted.
- The load must be under operator control at all times.

## Safety Precautions continued

- Do not connect pump to hydraulic system powered by another pump.

### Electric-Driven Motor



#### WARNING:

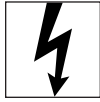

- Electrical work must be performed and tested by a qualified electrician per local directives and standards.
- Disconnect the pump from the power supply and relieve pressure before removing the motor case cover or performing maintenance or repair.
- Check the total amperage draw for the electrical circuit you will be using. *For example: Do not connect a pump that may draw 25 amps to a 20 amp fused electrical circuit.*
- Never use an ungrounded power supply with this unit.
- Changing the voltage is an involved and, if incorrectly performed, hazardous procedure. Consult the manufacturer for specific information before attempting rewiring.
- Wire pump motors for counterclockwise rotation when viewed from the shaft end of the motor.



- Do not attempt to increase the power line capacity by replacing a fuse with another fuse of higher value. Overheating the power line may result in fire.
- Exposing electric pumps to rain or water could result in an electrical hazard.
- Avoid conditions that can cause damage to the power cord, such as abrasion, crushing, sharp cutting edges, or corrosive environment. Damage to the power cord can cause an electrical hazard.

### Hoses



#### WARNING:



- Before operating the pump, tighten all hose connections using the correct tools. Do not overtighten. Connections should be only secure and leak-free. Overtightening can cause premature thread failure or high pressure fittings to split at pressures lower than their rated capacities.
- Should a hydraulic hose rupture, burst, or need to be disconnected, immediately shut off the pump and shift the control valve twice to release pressure. Never attempt to grasp a leaking hose under pressure with your hands. The force of escaping hydraulic fluid could cause serious injury.



- Do not subject the hose to potential hazard, such as fire, sharp surfaces, heavy impact, or extreme heat or cold. Do not allow the hose to kink, twist, curl, or bend so tightly that the fluid flow within the hose is blocked or reduced. Periodically inspect the hose for wear, because any of these conditions can damage the hose and possibly result in personal injury.
- Do not use the hose to move attached equipment. Stress can damage the hose and possibly cause personal injury.
- Hose material and coupler seals must be compatible with the hydraulic fluid used. Hoses also must not come in contact with corrosive material such as creosote-impregnated objects and some paints. Consult the manufacturer before painting a hose. Never paint the couplers. Hose deterioration due to corrosive materials may result in personal injury.

## Safety Precautions continued

---

- Avoid straight line tubing connections in short runs. Straight line runs do not provide for expansion and contraction due to pressure and/or temperature changes.
- Eliminate stress in the tube lines. Long tubing runs should be supported by brackets or clips. Tubes through bulkheads must have bulkhead fittings. This makes easy removal possible and helps support the tubing.
- Carefully inspect all hoses and fittings prior to use. Before each use, check entire hose for cuts, leaks, abrasion or bulging of cover, or damage or movement of couplings. If any of these conditions exist, replace the hose immediately. NEVER attempt to repair the hose.

### Cylinder



#### **DANGER:**

- Do not exceed rated capacities of the cylinders. Excess pressure may result in personal injury.
- Avoid off-center loads that could damage the cylinder and/or cause loss of the load.
- Read and understand all safety and warning decals and instructions for devices attached.
- Inspect each cylinder and coupler before each shift or usage to prevent unsafe conditions from developing.
- Do not use cylinders if they are damaged, altered or in poor condition.
- Do not use cylinders with bent or damaged couplers or damaged port threads.
- Under certain conditions, the use of an extension with a hydraulic cylinder may not be advisable and could present a dangerous condition.
- Avoid pinch points or crush points that can be created by the load or parts of the cylinder.
- To help prevent material fatigue if the cylinder is to be used in a continuous application, the load should not exceed 85% of the rated capacity or stroke.
- Cylinder must be on a stable base which is able to support the load while pushing or lifting.
- To help prevent personal injury, use shims, friction material or constraints to prevent slippage of the base or load.
- Do not set poorly-balanced or off-center loads on a cylinder.
- The load can tip or the cylinder can “kick out” and cause personal injury.
- Do not use the locking collar on a threaded piston as a stop. The threads may shear resulting in loss of the load.
- If this component is used to lift or lower loads, be certain that the load is under operator control at all times and that others are clear of the load.
- Do not drop the load.
- As the load is lifted, use blocking and cribbing to guard against a falling load.
- To help prevent personal injury, do not allow personnel to go under or work on a load before it is properly cribbed or blocked. All personnel must be clear of the load before lowering.
- Never use extreme heat to disassemble a hydraulic cylinder or ram. Metal fatigue and/or seal damage will result and can lead to unsafe operating conditions.





### IMPORTANT

- **Keep the cylinder clean at all times.**
- **While at a job site, when the cylinder is not in use, keep the piston rod fully retracted and upside down.**
- **Always use protective covers on disconnected quick couplers.**
- **When mounting cylinders or rams using the internal piston rod threads, collar threads, threaded tie rods or base mounting holes, the threads must be fully engaged. Always use SAE grade 8 or better fasteners when attaching components to cylinders or rams and tighten securely.**
- **Limiting the stroke and pressure on all cylinders will prolong their life.**

# Initial Setup

1. Remove all packing materials from the assembled unit.
2. Inspect the unit upon arrival. The carrier, not the manufacturer, is responsible for any damage resulting from shipment.

## Filling the Pump Reservoir/Bladder

Most pumps are shipped without hydraulic fluid in the reservoir or bladder. Hydraulic fluid may have been shipped in a separate container, but if hydraulic fluid is needed, use only approved Power Team hydraulic fluid rated at 47 cSt @ 38°C (215 SUS @ 100°F).

1. Clean the area around the filler cap to remove debris. Debris in the hydraulic fluid can damage the polished surfaces and precision-fit components of this pump.
2. Remove the filler cap and insert a clean funnel with filter.
3. Fill bladder to the top of filler. All air must be out of bladder.
4. Replace the filler cap.

**IMPORTANT: Tighten filler cap 1/2 - 1 turn after o-ring contacts sealing surface. Overtightening can cause pump damage.**

## Hydraulic Connections

1. Clean the areas around the fluid ports of the pump and cylinders.
2. Inspect all threads and fittings for signs of wear or damage, replace as needed.
3. Clean all hose ends, couplers or union ends.
4. Remove the thread protectors from the hydraulic fluid outlets.
5. Connect the hose assembly to the hydraulic fluid outlet, and couple the hose to the cylinder.



**CAUTION: To prevent personal injury from leaking hydraulic fluid, seal all hydraulic connections with a high-quality, non-hardening, pipe thread sealant.**



**IMPORTANT: Sealant tape or non hardening sealer tape can be used to seal hydraulic connections if only one layer of tape is used. Apply tape carefully, two threads back, to prevent it from being pinched by the coupler and broken off inside the system. Loose pieces of sealant could travel through the system and obstruct the flow of fluid or cause jamming of precision-fit parts.**

## Electric Motor Operation

Motor voltages are not changeable. They are:

12 VDC - 11-14 VDC

120 VAC - 90-130 VAC 50/60 Hz

220 VAC - 190-240 VAC 50/60 Hz

1. Verify the hydraulic valve is in the neutral or hold position.
2. Connect the motor to a power supply.

### Caution:

- **The correct voltage is required for the pump to operate. Verify the voltage rating on the pump motor name plate matches the outlet or power source you are using. Low voltage may cause: an overheated motor; a motor that fails to start under load; motor surging when trying to start; or a stalled motor before maximum pressure is reached.**

- Check the voltage at the motor with the pump running at full pressure.
  - Never run the motor on long, light gauge extension cords. Refer to Table 2. Minimum Recommended Gauge Table.
3. Start the pump and shift as required.
  4. Turn off the pump when not in use.

AMPS at Maximum Hyd. Pressure	Electrical Cord Size AWG (mm <sup>2</sup> ) 3.2 Volt Drop Length of Electrical Cord							
	mm <sup>2</sup>				AWG			
	0-8 m	8-15 m	15-30 m	30-46 m	0-25 ft	25-50 ft	50-100 ft	100-150 ft
6	0.75	1	1.5	2.5	18	16	14	12
10	0.75	1.5	2.5	4	18	14	12	10
14	1	2.5	4	6	16	12	10	8
18	1.5	2.5	6	6	14	12	8	8
22	1.5	4	6	10	14	10	8	6
26	2.5	4	6	10	12	10	8	6
30	2.5	4	10	16	12	10	6	4

**Table 2. Minimum Recommended Gauge Table**

### Bleeding Air from the System

After all connections are made, the hydraulic system must be bled of any trapped air. See Figure 2. With no load on the system and the pump vented and positioned higher than the hydraulic device, cycle the system several times. Check the reservoir fluid level and fill to proper level with Power Team hydraulic fluid as necessary. If there is a problem contact Power Team.

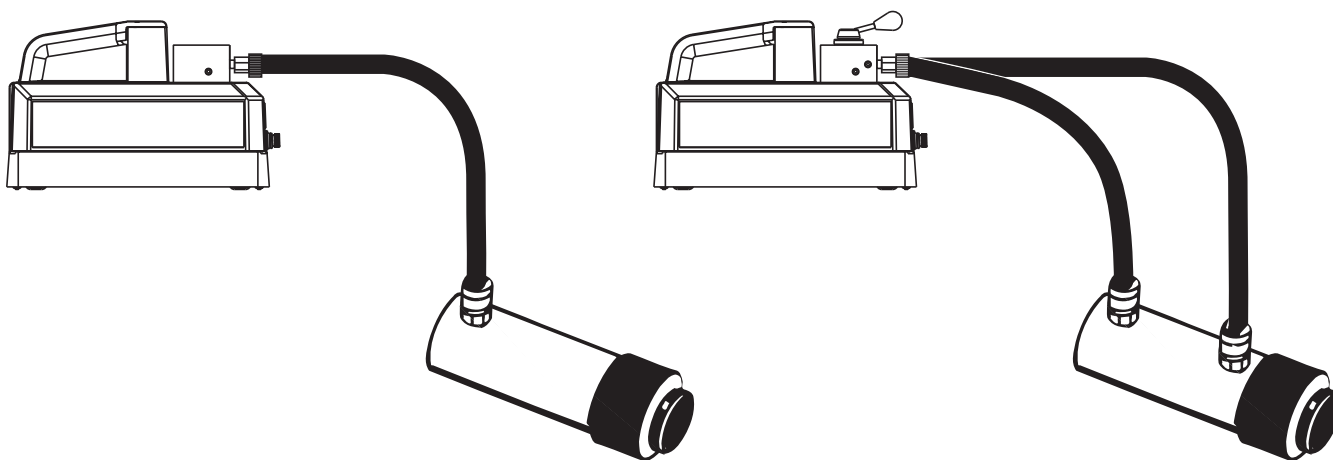

**Figure 2. System Bleeding**

## Initial Setup continued

**IMPORTANT:** Some spring return cylinders have a cavity in the rod which forms an air pocket. This type of cylinder should be bled when positioned upside down or lying on its side with the port facing upward.

### Hydraulic Pressure Gauge (optional)

#### Automatic Dump Valve

To monitor line pressure when using an automatic dump valve, a T-adapter is used between the valve and the pressure switch to adapt a hydraulic pressure gauge.

#### Posi-Check Valve

If a Posi-Check valve is used, a hydraulic gauge shows zero pressure when the valve is switched to the neutral (hold) position. Cylinder pressure, however, is held without loss. If reading the cylinder pressure, a gauge must be installed in the outlet port of the valve.

To install a hydraulic pressure gauge (for PE102):

1. A T-adapter (PN 9760) is necessary. See Figure 3. Install T-adapter.
2. Install sealant tape or non-hardening sealer to a T-adapter. Install the T-adapter as shown.
3. Install sealant tape or non-hardening sealer to the gauge.
4. Install the pressure gauge.

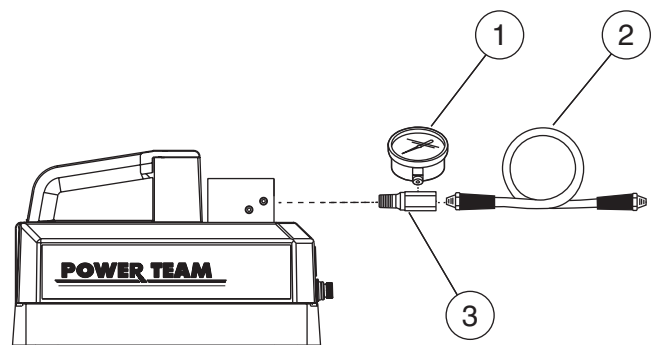

Item	Description
1	Gauge
2	Hose
3	T-adapter

Figure 3. 10 Series Gauge

To install a hydraulic pressure gauge (for PE104):

1. See Figure 4. Remove the pipe plug from the valve's gauge port.

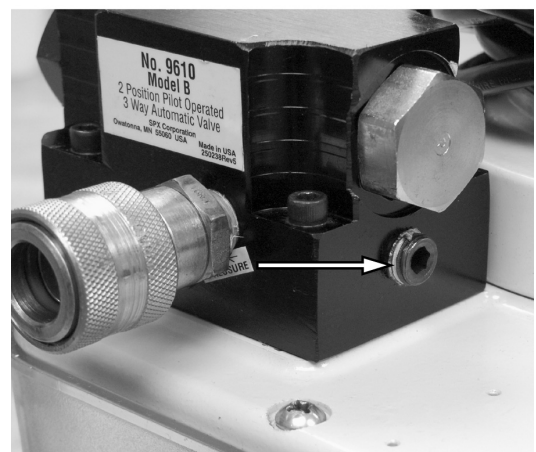

Figure 4. Gauge Port

## Initial Setup continued

2. See Figure 5. Install sealant tape or non hardening sealer to a 45 degree elbow (PN 9678). Install the elbow as shown.
3. Install sealant tape or non hardening sealer to the gauge.



**Figure 5. Elbow Installation**

4. See Figure 6. Install the pressure gauge.

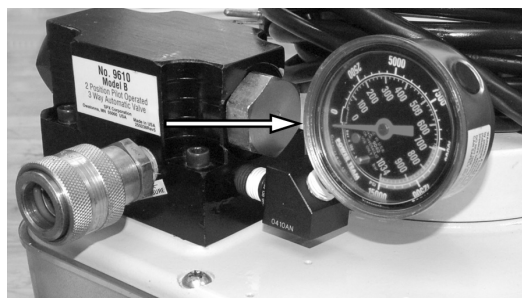

**Figure 6. Pressure Gauge Installation**

# Operating Instructions

## Bleeding Air from the System

1. Cycle the hydraulic system until operation is smooth and consistent.
2. Check the pump reservoir level. Add Power Team hydraulic fluid as needed.

## Motor Control Operation

1. If necessary, connect the power cord to an appropriate power source.
2. See Figure 7. Place the motor control switch located in the handle in the ON position.

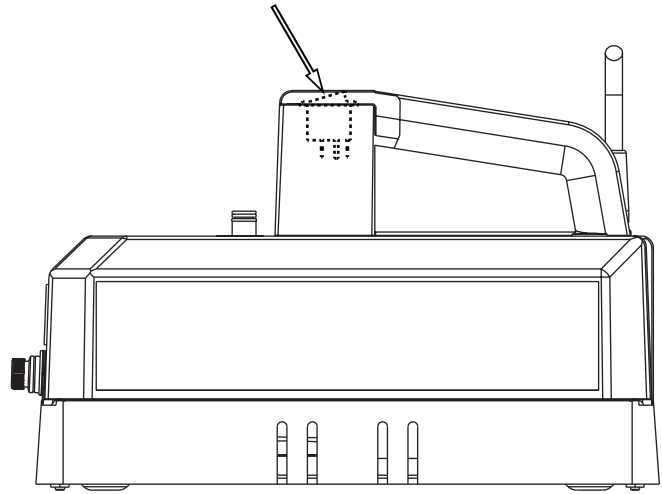

**Figure 7. PE10 Motor Control Switch**

# Performance Specifications

The information in the following charts can be used as a basis to determine if the system is performing as expected during operation.

Pump	RPM	Amp Draw at 690 bar (10,000 psi) (115V)	Amp Draw at 690 bar (10,000 psi) (230V)	dBa at Idle and 690 bar (10,000 psi)	Air Supply Req'd bar (psi)
PE10		6	3	68-74	N/A

**Table 3. Drive Unit Requirements**

Pump	Max. Pressure Output bar (psi)	Fluid Delivery** (cu. in./min. @)					
		0 bar (0 psi)	7 bar (100 psi)	50 bar (700 psi)	70 bar (1,000 psi)	345 bar (5,000 psi)	690 bar (10,000 psi)
PE10	690 bar (10,000 psi)	120	-	-	-	-	10

\*\* Typical delivery. Actual flow varies with field conditions.

**Table 4. Fluid Pressure Chart**

# General Maintenance



## WARNING:



- **Disconnect the unit from the power supply before performing maintenance or repair procedures.**
- **Repairs and maintenance are to be performed in a dust-free area by a qualified technician.**

## System Evaluation

The components of your hydraulic system — cylinders, pumps, hoses, and couplings — all must be:

- Rated for the same maximum operating pressure.
- Correctly connected.
- Compatible with the hydraulic fluid used.

A system that does not meet these requirements can fail, possibly resulting in serious injury. If you are in doubt about the components of your hydraulic system, contact Power Team Technical Support.

## Inspection

Keep a dated and signed inspection record of the equipment. Before each use, the operator or other designated personnel should visually inspect for the following conditions:

- Cracked or damaged cylinder.
- Excessive wear, bending, damage, or insufficient thread engagement.
- Leaking hydraulic fluid.
- Scored or damaged piston rod.
- Incorrectly functioning or damaged heads and caps.
- Loose bolts or cap screws.
- Damaged or incorrectly assembled accessory equipment.
- Modified, welded, or altered equipment.
- Bent or damaged couplers or port threads.

## Periodic cleaning



**WARNING: Contamination of the hydraulic fluid could cause the valve to malfunction. Loss of the load or personal injury could result.**

Establish a routine to keep the hydraulic system as free from debris as possible.

- Seal unused couplers with dust covers.
- Keep hose connections free of debris. Equipment attached to a cylinder must be kept clean.
- Keep the breather-hole in the filler cap clean and unobstructed.
- Use only Power Team hydraulic fluid. Replace hydraulic fluid as recommended, or sooner if the fluid becomes contaminated. Never exceed 300 hours of use between fluid changes.

## Hydraulic Fluid Level

1. Check the fluid level in the reservoir after each 10 hours of use. The fluid level should be checked when all cylinders are retracted.
2. Drain, flush, and refill the reservoir with an approved Power Team hydraulic fluid after every 300 hours of use. The frequency of fluid changes depends upon general working conditions, severity of use, the overall cleanliness and care given to the pump. Fluid should be changed more frequently when the system is not operated regularly indoors.



### Adding Hydraulic Fluid to the Reservoir or Bladder

1. Retract the cylinder(s) devices.
2. Disconnect the power supply.
3. Clean the entire area around the filler plug.
4. Remove the filler plug, and install a clean funnel with a filter.
5. Use only Power Team hydraulic fluid 47 cSt @ 38°C (215 SUS @ 100°F).

### Sound Reduction - Electrically Powered Motor

The electrically powered hydraulic pump operates in the 90-95 dBA range. If further sound reduction is desired, any of the following options will help reduce the sound level.

1. Install a pressure switch to automatically shut off the motor when maximum pressure is reached (holding cycle).
2. Contact Power Team Hydraulic Technology technical support for products more suitable to your application.

### Hose Connections



**CAUTION:** To prevent personal injury from leaking hydraulic fluid, seal all hydraulic connections with a high-quality, non-hardening, pipe thread sealant.



**IMPORTANT:** Sealant tape or non-hardening sealer tape can be used to seal hydraulic connections if only one layer of tape is used. Apply tape carefully, two threads back, to prevent it from being pinched by the coupler and broken off inside the system. Loose pieces of sealant could travel through the system and obstruct the flow of fluid or cause jamming of precision-fit parts.

### Storage

Store the unit in a dry, well-protected area where it will not be exposed to corrosive vapors, dust, or other harmful elements. If a unit has been stored for an extended period of time, it must be thoroughly inspected before it is used.

# Troubleshooting Guide



## WARNING:

- Repair work or troubleshooting must be performed by qualified personnel who are familiar with this equipment.
- Disconnect the power supply before removing the electrical cover. Electrical work should be performed by a qualified electrician.
- Check for system leaks by using a hand pump to apply pressure to the suspect area. Watch for leaking fluid and follow it back to its source. Never use your hand or other body parts to check for a possible leak.



## Notes:

- For a detailed parts list or to locate a Power Team Authorized Hydraulic Service Center, contact your nearest Power Team facility.
- Plug the outlet ports of the pump when checking for leakage to determine if the leakage is in the pump, in the cylinder, or in the tool.

Problem	Cause	Solution
<b>Electric motor does not run.</b>	1. Pump not turned ON.	1. Position switch to RUN position.
	2. Unit is not plugged in.	2. Plug in unit.
	3. No voltage supply.	3. Check line voltage. Check reset button on power panel.
	4. Worn brushes.	4. Replace brushes.
	5. Circuit breaker tripped because total amperage draw too high for existing circuit.	5. Use an alternate circuit or have a qualified electrician add an additional circuit.
	6. Overheated motor (single-phase motor). Magnetic starter disengaged (three-phase motor). Thermal protector open.	6. Wait for motor to cool before restarting. Reset thermal protector. (Single-phase motor will reset automatically.)
	7. Faulty thermal protector (single-phase motor). Faulty magnetic starter (three-phase motor).	7. Replace defective parts.
<b>Electric motor will not shut off.</b>	1. Defective motor controls.	1. Disconnect unit from power supply; contact a Power Team Service Center.
<b>Electric motor stalls, surges, overheats, or will not start under load.</b>	1. Low voltage	1. Refer to electric motor information in Initial Setup section.
	2. Electrical cord size too small.	2. Refer to electrical cord chart in Initial Setup section.
<b>Electrical overload protector keeps tripping.</b>	1. Wired incorrectly.	1. Disconnect unit from power supply; have qualified electrician review motor and circuit wiring.

## Troubleshooting Guide continued

Problem	Cause	Solution
<b>Pump delivers excess fluid pressure.</b>	1. Faulty pressure gauge.	<i>1. Replace gauge.</i>
	2. Relief valve set incorrectly.	<i>2. Contact a Power Team Service Center.</i>
<b>Pump is not delivering fluid, or delivers only enough fluid to advance connected components partially or erratically or operation to slow.</b>	1. Fluid level too low.	<i>1. Add fluid, refer to filling the pump reservoir in Initial Setup section.</i>
	2. Loose-fitting coupler to component.	<i>2. Verify quick-disconnect couplings to cylinders are completely coupled. Couplers may need to be replaced because ball check does not stay open due to wear.</i>
	3. Air in system.	<i>3. Refer to Initial Setup in this manual to bleed air from system.</i>
	4. Air leak in suction line.	<i>4. Check and tighten suction line.</i>
	5. Debris in pump or filter plugged.	<i>5. Clean pump filter. If problem persists, disconnect from power supply contact authorized Power Team service center.</i>
	6. Fluid bypasses through the double-acting cylinder.	<i>6. Remove cylinder; cap hoses. Check pump and valve for leaks.</i>
	7. Cold fluid or fluid too heavy. (Hydraulic fluid is of a higher viscosity than necessary.)	<i>7. Drain, flush, and refill reservoir using a lighter weight fluid. Refer to General Maintenance section.</i>
	8. External relief valve or low pressure unloading valve out of adjustment.	<i>8. Refer to Adjusting the Pressure Regulating Valve.</i>
	9. Power unit/reservoir capacity is too small for the size of the cylinder(s) used.	<i>9. Use smaller cylinder(s) or larger reservoir.</i>
	10. Vacuum in reservoir.	<i>10. Clean plugged vent in filler plug.</i>
<b>Pump builds pressure but cannot maintain pressure.</b>	1. Fluid leakage.	<i>1. Look for external leaks. If no fluid leakage is visible, the problem is internal. If using a double-acting cylinder, remove it from the system to ensure the leak is not in the cylinder. Seal leaking pipe fittings with pipe sealant.</i>
	2. Leaking pressure switch seal.	<i>2. Replace pressure switch.</i>

## Troubleshooting Guide continued

<b>Problem</b>	<b>Cause</b>	<b>Solution</b>
<b>Pump does not build to full pressure.</b>	1. Faulty pressure gauge.	<i>1. Replace pressure gauge.</i>
	2. Check for external leakage.	<i>2. Seal faulty pipe fittings with pipe sealant.</i>
	3. Check external pressure regulator. Check relief valve setting.	<i>3. Refer to Adjusting the Pressure Regulating Valve.</i>
	4. Look for internal leakage in double-acting cylinders.	<i>4. Remove cylinder from pump. If pump builds full pressure, cylinder is defective.</i>
	5. Inadequate air pressure (air motor only).	<i>5. Refer to Initial Setup section.</i>
<b>Erratic action</b>	1. Air in system.	<i>1. Check for leaks. Refer to bleeding procedure.</i>
	2. Internal leakage in attached components.	<i>2. Refer to manufacture's information for attached component.</i>
	3. Attached component sticking or binding.	<i>3. Refer to manufacture's information for attached component.</i>
	4. Malfunctioning valve.	<i>4. Verify connections. Contact authorized Power Team Service Center.</i>

## Power Team Facilities



UNITED  
STATES

SPX Hydraulic Technologies  
5885 11th Street  
Rockford, IL 61109-3699  
USA  
Telephone: 1-815-874-5556  
FAX: 1-815-874-7853

Cust. Service/Order Entry  
Tel: 1-800-541-1418  
FAX: 1-800-288-7031  
E-mail:  
info@powerteam.com

Technical Services  
Tel: 1-800-477-8326  
FAX: 1-800-765-8326

CHINA

No. 1568 Hua Shan Road  
International Park Center  
Shanghai 200052, China  
Tel: 86 (21) 2208-5888  
FAX: 86 (21) 2208-5682  
E-mail  
infochina@powerteam.com

FAR EAST

7 Gul Circle  
Singapore 629563  
Singapore  
Tel: (65) 6265-3343  
FAX: (65) 6265-6646  
E-mail:  
infoasia@powerteam.com

EUROPE

Albert Thijsstraat 12  
6471 WX Eygelshoven  
The Netherlands  
Tel: 31 (45) 5678877  
FAX: 31 (45) 5678878  
E-mail  
infoeurope@powerteam.com

For more information, Internet address: <http://www.powerteam.com>



## Operating Instructions for:

PE102	PE102A-220-FE	PE104-220
PE102A	PE102A-AERO	PR102
PE102-28-DC	PE102A-COR	PR102-AMP
PE102-28-220DC	PE102A-EMP	P2102-ANCHOR
PE102-28-FSC	PE102A-ETT	PR102A
PE102-220	PE102AR	PR102A-FE
PE102-ANCHOR	PE102AR-220	PR104
PE102A-220	PE104	PR102-HURST-EPR

## ELECTRIC HYDRAULIC PUMP

Max. Capacity: 10,000 PSI

### NOTE:

- Inspect the pump upon arrival.
- Read and carefully follow these instructions. Most problems with new equipment are caused by improper operation or installation.

NOTE: These instructions cover several standard pumps. Some special units may appear different or have different specifications. Direct any questions to an appropriate Authorized Hydraulic Service Center or our Technical Services Department.

## SAFETY PRECAUTION



### WARNING

- All WARNING statements must be carefully observed to prevent personal injury.

### General Operation

- Before operation the pump, all hose connections must be tightened with proper tools. Do not overtighten. Connections need only be tightened securely and leak-free. Overtightening may cause premature thread failure or may cause high pressure fittings to split at pressures lower than their rated capacities.
- Should a hydraulic hose ever rupture, burst, or need to be disconnected, immediately shut off the pump and shift the control valve twice to release all pressure. Never attempt to grasp a leaking hose under pressure with your hands. The force of escaping hydraulic fluid could cause serious injury.
- Do not subject the hose to potential hazard such as fire, extreme heat or cold, sharp surfaces, or heavy impact. Do not allow the hose to kink, twist, curl, or bend so tightly that the oil flow within the hose is blocked or reduced. Periodically inspect the hose for wear because any of these conditions can damage the hose and possibly result in personal injury.
- Do not use the hose to move attached equipment. Stress may damage the hose and possibly cause personal injury.
- Hose material and coupler seals must be compatible with the hydraulic fluid used. Hoses also must not come in contact with corrosive materials such as creosote-impregnated objects and some paints. Consult the manufacturer before painting a hose. Never paint the couplers. Hose deterioration due to corrosive materials may result in personal injury.

## Safety Precautions (Continued)

### Pump

- Do not exceed the PSI hydraulic pressure rating noted on the pump name plate or tamper with the internal high pressure relief valve. Creating pressure beyond rated capacities may result in personal injury.
- Before replenishing the oil level, retract the system to prevent overfilling the pump bladder. An overfill may cause personal injury due to excess bladder pressure created when cylinders are retracted.

### Cylinder

- Do not exceed rated capacities of the cylinders. Excess pressure may result in personal injury.
- Do not set poorly-balanced or off-center loads on a cylinder. The load may tip and cause personal injury.

### Electrical Supply

- Do not use an ungrounded (two-prong) extension cord (except for 12 VDC).
- Avoid conditions which could create an electrical hazard.
- If the power cord is damaged or wiring exposed, replace or repair immediately.

## SET-UP AND OPERATION

### Electric Motor



**WARNING** To help avoid possible personal injury,

- Any electrical work must be done by a qualified electrician.
- Disconnect the power supply before removing the motor casing cover or performing repairs or maintenance.

### Voltages

Motor voltages are not changeable. They are:

12 VDC	-	11-14 VDC
120 VAC	-	90-130 VAC 50/60 Hz
220 VAC	-	190-240 VAC 50/60 Hz

### Hydraulic Set-up

1. Clean the areas around the oil ports of the pump and hydraulic cylinders.
2. Inspect the threads and fittings for signs of wear or damage and replace as needed. Clean all hose ends, couplers, and union ends.
3. Remove the thread protectors from the hydraulic outlets. Connect the hose assembly to the valve and couple the hose to the cylinder.
4. Seal all pipe connections with a high quality pipe thread sealant. PTFE tape can be used to seal hydraulic connections provided only one layer of tape is used. Apply the tape carefully, two threads back, to prevent it from being pinched by the coupler and broken off inside the pipe end. Any loose pieces of tape could travel through the system and obstruct the flow of oil or cause jamming of precision-fit parts.

### Filling the Bladder

1. Thoroughly clean the area around the filler cap with a clean cloth to prevent contamination of the oil by foreign particles.
2. Retract all cylinders.
3. Remove the filler cap and insert a clean funnel with filter. Bladder must be filled to the top of filler. All air must be out of bladder.
4. Replace filler cap. **IMPORTANT: Tighten filler cap 1/2 - 1 turn after o-ring contacts sealing surface. Overtightening can cause pump damage.**



**Valve Operation**

**2-Position, 2-Way Manual Valves used with Single-acting Cylinders**

1. To build pressure, turn the valve control handle counterclockwise (CCW).
2. Start the pump by pressing the motor control ON/OFF switch.  
**NOTE: Oil advances the cylinder when the unit is activated.**
3. When the cylinder has advanced to the desired position, release the motor control ON/OFF switch.
4. To retract the cylinder, turn the valve control clockwise (CW).

**NOTE: The valve works the same as the manifold if the pump is operated with the valve in the RETURN position. In this position, the cylinder advances when the pump is running and retracts when the motor is stopped.**

**When the valve is in the HOLD position, the cylinder advances when the pump is running and holds when the motor is stopped. The cylinder can be retracted, with the pump off, by moving the valve to the RETURN position.**

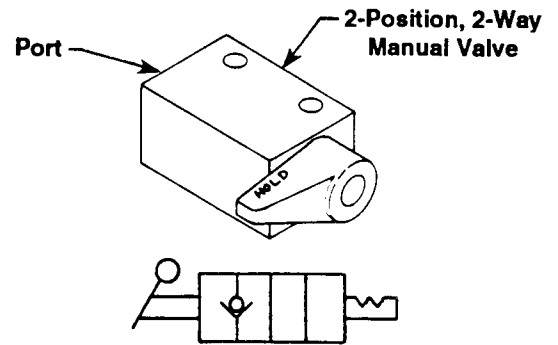

**Manifold Assembly used with Single-acting Cylinders or Remote Valves**

1. Start the pump by pressing the motor control ON/OFF switch.  
**NOTE: Oil advances the cylinder when the unit is activated.**
2. When the cylinder has advanced to the desired position, release the motor control ON/OFF switch. The cylinder will retract.

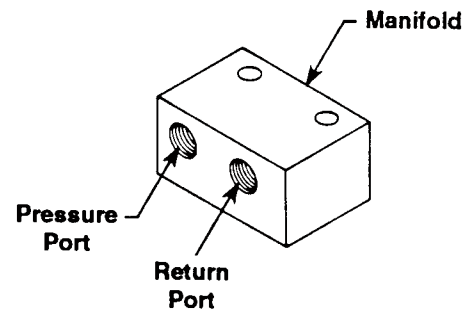

**Tandem Center 4-Way Control Valve used with Double-acting Cylinders**

1. Place the valve control lever in the NEUTRAL or hold position.
2. Start the pump by pressing the motor control ON/OFF switch.
3. Advance the cylinder by shifting the valve control lever to the ADVANCE position.
4. When the cylinder has advanced to the desired position, release the motor control ON/OFF switch. Cylinder will hold pressure.

**NOTE: The cylinder momentarily loses pressure during the transition between valve positions.**

5. Retract the cylinder by shifting the valve control lever to the RETRACT position and pressing the motor control ON/OFF switch. Cylinder will retract as long as switch is held.

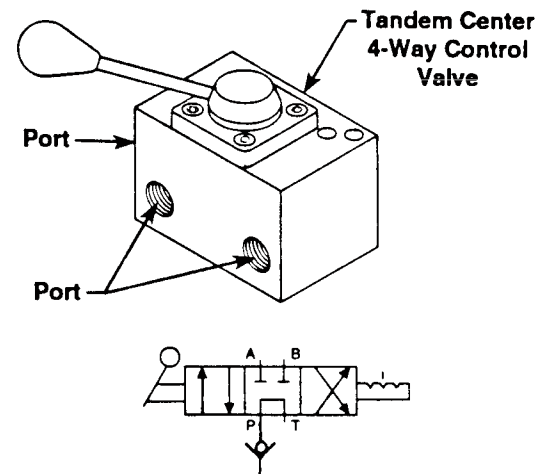

**Pressure Regulator**

A pressure regulator can be adjusted to bypass oil at a desired pressure setting while the pump motor continues to run.

**IMPORTANT: For easy adjustment of the pressure regulator, always adjust the pressure by INCREASING it to a desired pressure setting. The pressure range for these pumps is from 1,000 PSI to 10,000 PSI.**

1. Loosen the regulator locking nut, and turn the adjusting knob a few turns counterclockwise (CCW) to decrease the pressure setting to a lower than desired pressure.
2. Connect the pump completely. Place the pump's rocker switch in the ON position.
3. Slowly turn the adjusting knob in a clockwise (CW) direction to gradually increase the pressure setting. When the desired pressure setting is reached, lock the adjusting knob into position by tightening the locking nut.

## Pressure Switch

A pressure switch can be adjusted to stop the pump motor at a desired pressure setting and restart the motor when the pressure falls below that setting.

It is recommended that a pressure switch be used with a pressure regulating valve to insure accuracy when setting a maximum PSI level. A pressure switch alone will break the motor's energy supply at a selected setting, but the hydraulic pump will continue building pressure as it slows to a stop. The pressure regulating valve is adjusted at a setting slightly above the pressure switch setting to compensate by releasing the pressure developed by the hydraulic pump as it "coasts" to a stop. As a result, the pressure limit requirement can be held to approximately 300 PSI.

## Adjusting The Pressure Switch Setting

1. Loosen the locknut on the pressure switch. Slowly turn the pressure switch adjusting screw in a counterclockwise (CCW) direction, decreasing the pressure switch setting until the pump motor shuts off. Tighten the locknut to lock the adjusting screw.
2. Release the hydraulic pressure. Run the pump to check the pressure setting and automatic shutoff of the motor. It may be necessary to make a second fine adjustment.

## PREVENTIVE MAINTENANCE



**WARNING** To help avoid possible personal injury,

- **Disconnect the pump from the power supply before performing maintenance or repair procedures.**
- **Repairs and maintenance should be performed in a dust-free area by a qualified technician.**

## Bleeding Air from the System

Air can accumulate in the hydraulic system. This air causes the cylinder to respond in an unstable or slow manner. To remove the air:

1. Position hydraulic cylinder(s) on their sides with the couplers located upward and at a lower level than the pump.
2. Remove any load from the cylinder(s), and cycle the hydraulic system through several cycles (fully extend and retract the cylinders).
3. The bladder must be vented and refilled (see "Filling the Bladder" section on sheet 2 of 3).

## Hydraulic Fluid Level

1. Check the oil level in the bladder after each 10 hours of use. With all cylinders retracted and the pump in the upright (or vertical) position, the oil level should be at the top of the filler hole.
2. When adding oil, use Power Team approved, high-grade hydraulic oil (215 SSU @ 100°F). Retract the cylinders and disconnect the power supply. Clean the area around the filler plug, remove the plug, and insert a clean funnel with filter.
3. The frequency of oil changes will depend upon the general working conditions, severity of use, and overall cleanliness and care given the pump. Three hundred hours of use under general shop conditions is considered a standard change interval. Drain, flush, and refill the bladder with Power Team approved, high-grade hydraulic oil (215 SSU @ 100°F).

## Maintenance and Cleaning

1. Keep the pump's outer surface as free from dirt as possible.
2. Seal all unused couplers with thread protectors.
3. Keep all hose connections free of dirt and grime.
4. Equipment connected to the pump must be kept clean.
5. Use only Power Team approved, high-grade hydraulic oil in this pump.  
Change as recommended (approx. every 300 hours).

**ELECTRICAL SCHEMATIC 115/230 V., 50/60 Hz,  
SINGLE PHASE**

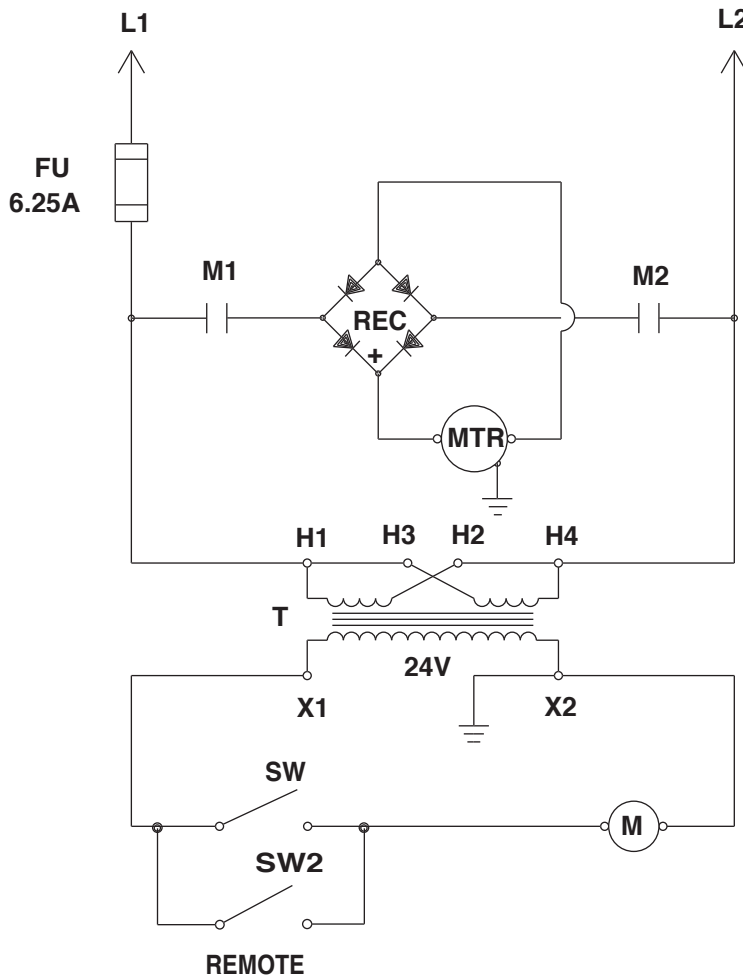

Transformer Connections:

**For 115 VAC**  
 H1 & H3 to L1  
 H2 & H4 to L2

**For 230 VAC**  
 H1 to L1  
 H2 to H3  
 H4 to L2

## ELECTRICAL SCHEMATIC 12 VDC (CCW ROTATION FROM LEAD END)

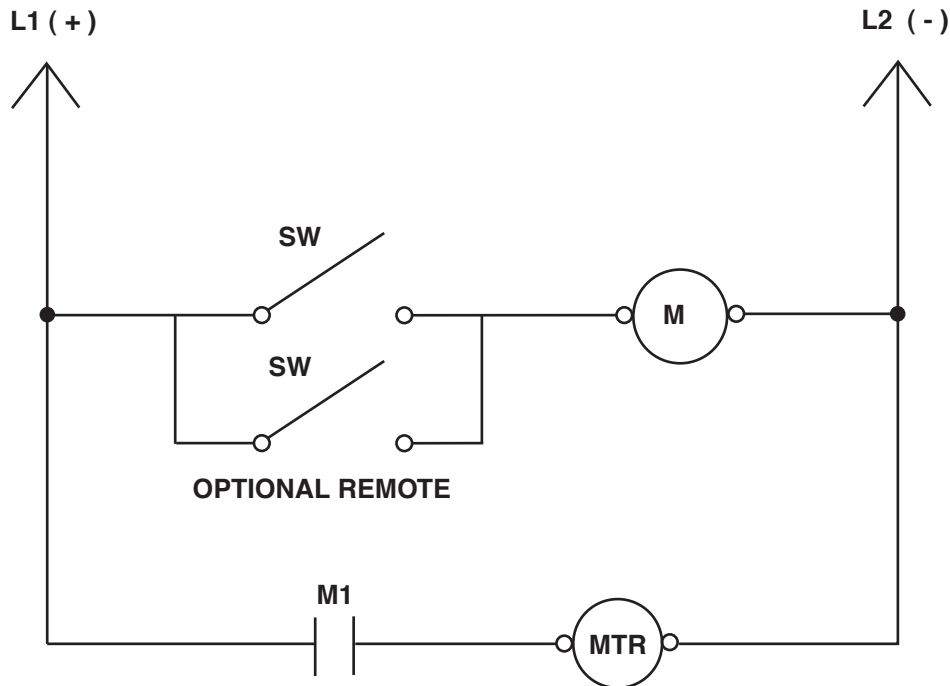

# POWER TEAM®



WORLD HEADQUARTERS  
THE AMERICAS CUSTOMER  
SERVICE CENTER  
5885 11TH STREET  
ROCKFORD, ILLINOIS 61109  
TEL: 1-815-874-5556  
CUSTOMER SERVICE/ORDER ENTRY  
TEL: 1-800-541-1418  
FAX: 1-800-288-7031

E-MAIL: [INFO@POWERTEAM.COM](mailto:INFO@POWERTEAM.COM)



EUROPEAN CUSTOMER  
SERVICE CENTER  
ALBERT THIJSSRAAT 12  
6471 WX EYGELSHOVEN  
THE NETHERLANDS  
TEL: (31) 45 5678877  
FAX: (31) 45 5678878

E-MAIL: [INFOEUROPE@POWERTEAM.COM](mailto:INFOEUROPE@POWERTEAM.COM)

ASIA PACIFIC CUSTOMER  
SERVICE CENTER  
7 GUL CIRCLE  
SINGAPORE 629563, SINGAPORE  
TEL: (65) 6265-3343

E-MAIL: [INFOASIA@POWERTEAM.COM](mailto:INFOASIA@POWERTEAM.COM)

CHINA (CCSC)

NO: 1568, HUA SHAN ROAD,  
TREASURY BUILDING,  
11TH FLOOR,  
SHANGHAI 200052, CHINA  
TEL: 86 (21) 2208 5888  
FAX: 86 (21) 2208 5682

E-MAIL: [INFOCHINA@POWERTEAM.COM](mailto:INFOCHINA@POWERTEAM.COM)