

SG4™, SG6™ SG11™

SECURE-GRIP MECHANICAL FLANGE SPREADERS

Operator Instruction Manual



EQUALIZER[™]
INTERNATIONAL

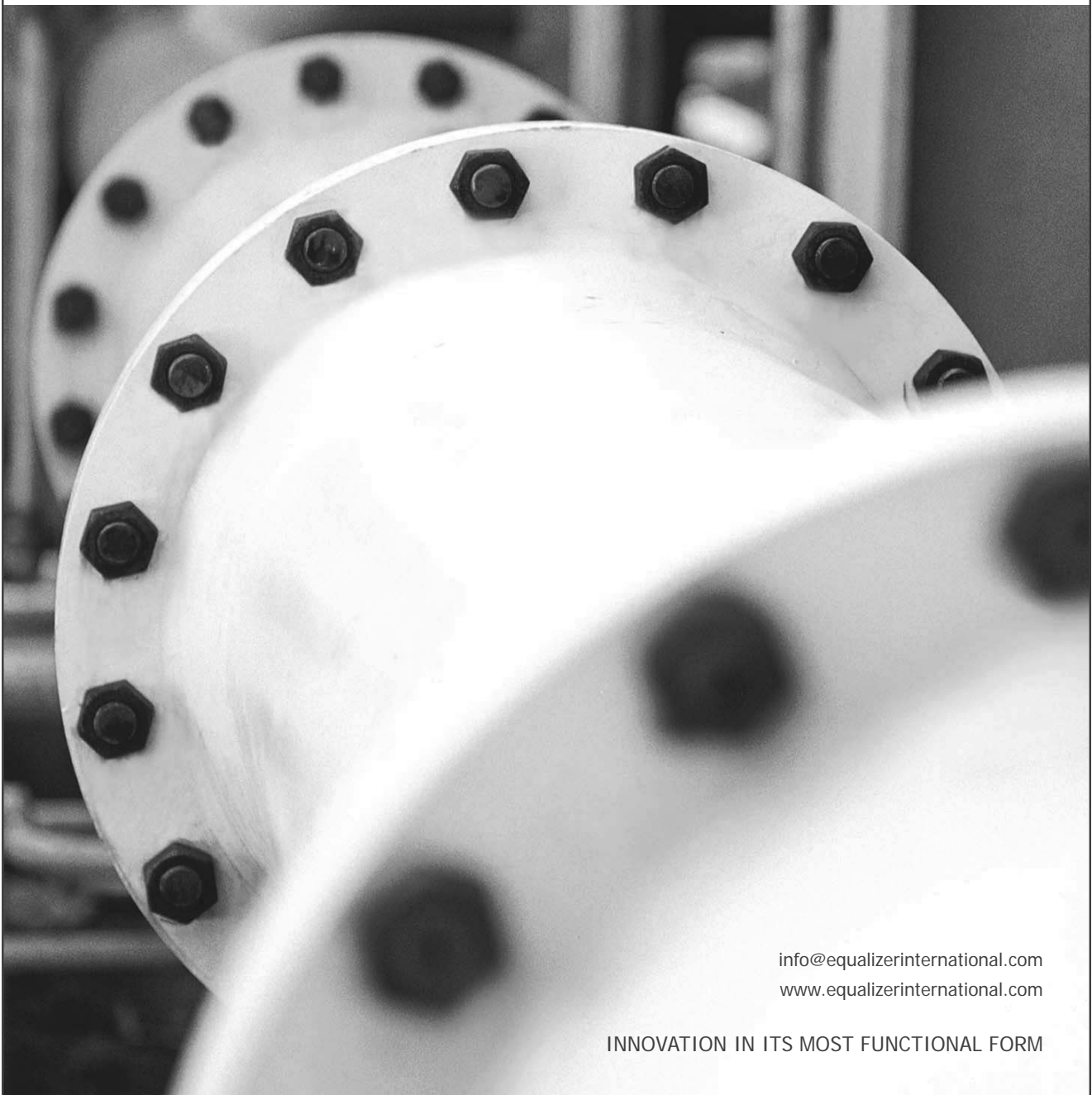

info@equalizerinternational.com
www.equalizerinternational.com

INNOVATION IN ITS MOST FUNCTIONAL FORM



INDEX

SECTION	CONTENTS	PAGE NO.
1	INTRODUCTION	1
2	SAFETY INFORMATION	2-3
3	SG4 TM KIT COMPONENTS & TECHNICAL DATA	4
4	SG6 TM KIT COMPONENTS & TECHNICAL DATA	5
5	SG11 TM KIT COMPONENTS & TECHNICAL DATA	6
6	HOW THE SECURE-GRIP MECHANICAL TOOLS WORK	7
7	INSTALLATION AND OPERATION	8-18
	7.1 COLLET SELECTION BASED ON FLANGE SPECIFICATION	8
	7.2 COLLET SELECTION BASED ON BOLT-HOLE MEASUREMENT	9-11
	7.3 COLLET REMOVAL AND REPLACEMENT	12
	7.4 INSTALLATION AND OPERATION	13-18
	7.5 VALVE, SPADE OR BLIND REMOVAL, INSTALLTION AND OPERATION	19-20
8	EXAMINATION, MAINTENANCE AND STORAGE	21-23
9	PARTS LISTS	24-26
10	WEIGHTS AND DIMENSIONS	27
11	TROUBLESHOOTING	28-29
12	SECURE-GRIP TOOL RANGE	30
13	RANGE OF APPLICATION CHARTS	31-40

1. INTRODUCTION

The Equalizer Secure-Grip Flange Spreading Tools are a range of tools designed to assist in the maintenance and installation of pipeline flange assemblies.

The Mechanical Secure-Grip Flange Spreading Tools are used to spread flanges with little or no access gap producing a spreading force of up to:

- **7.4 T (74 kN)** for the **SG4TM** when used in pairs
- **12 T (120 kN)** for the **SG6TM** when used in pairs
- **22 T (220 kN)** for the **SG11TM** when used in pairs



2. SAFETY INFORMATION

The operator MUST read this manual prior to using the tools.

Failure to comply with the following cautions and warnings could cause equipment damage and personal injury; read the manual fully!

Read all the following instructions, warnings and cautions carefully. Follow all safety precautions to avoid personal injury or property damage during system operation.

Equalizer International Ltd cannot be responsible for damage or injury resulting from unsafe product use, lack of maintenance or incorrect product and/or system operation. Contact Equalizer International Ltd when in doubt as to the safety precautions and applications.

In all installations the site safety requirements must be adhered to. ALSO the safety of the operator, and when present, any assisting personnel, is of paramount importance along with the safety of others including, when present, the general public.

These instructions are only to cover the safe operation of THE EQUALIZER SG4™, SG6™ & SG11™ SECURE-GRIP MECHANICAL TOOLS during normal maintenance/installation operations. All other safety aspects must be controlled by the operation supervisor.



A **CAUTION** is used to indicate correct operating or maintenance procedures and practices to prevent damage to, or destruction of equipment or other property.

A **WARNING** indicates a potential danger that requires correct procedures or practices to avoid personal injury.

A **DANGER** is only used when your action or lack of action may cause serious injury or even death.



IMPORTANT: Operator must be competent in the use of mechanical equipment. The operator must have read and understood all instructions, safety issues, cautions and warnings before starting to operate the Equalizer equipment.



WARNING: Do not overload equipment. Overloading causes equipment failure and possible personal injury.



CAUTION: Make sure that all system components are protected from external sources of damage, such as excessive heat, flame, moving machine parts, sharp edges and corrosive chemicals.



WARNING: Immediately replace worn or damaged parts with genuine Equalizer parts. Equalizer parts are designed to fit properly and withstand rated loads. For repair or maintenance service contact your Equalizer distributor or service centre.



DANGER: To avoid personal injury keep hands and feet away from the tool and workpiece during operation.



WARNING: Always wear suitable clothing and Personal Protective Equipment (PPE).



WARNING: Never place fingers in a joint held by an activated tool



CAUTION: Never hammer nor force the tool into a bolt hole; if it does not fit easily you are using the wrong size of tool.



CAUTION: Do not operate the equipment without lubricating all moving parts as in section 8. Use only high pressure molybdenum disulphide grease.



3. SG4TM KIT COMPONENTS & TECHNICAL DATA

SG4TM KIT COMPONENTS

- 1 x SG4TM Tool
- 1 x 150 mm (6") Vernier Calliper
- 1 x 3/8" Drive Torque Wrench and 16 mm Socket
- 1 x Safety Block
- 2 x M16 (5/8") Collets
- 2 x M20 (3/4") Collets
- 1 x Instruction Manual
- 1 x Carry-Case with Protective Foam Inserts



Product Code: SG4TMSTD

SG4TM TECHNICAL DATA

Spreading force = 3.7 T (37 kN) per tool

It is recommended that tools are used in pairs positioned 180° apart, giving
2 x 3.7 = 7.4 T (74 kN)

The spreading force can be determined by pre-setting the torque wrench. The torque settings will produce a spreading force as set out below.

					Max.
Torque wrench setting	N/m	27	34	41	47
	ft/lb	20	25	30	35
Spreading force	T	2.2	2.5	3.3	3.7
	kN	22	25	33	37

Spreading distance = 0 - 75 mm (0 - 2.95")



4. SG6TM KIT COMPONENTS & TECHNICAL DATA

SG6TM KIT COMPONENTS

- 1 x SG6TM Tool
- 1 x 150 mm (6") Vernier Calliper
- 1 x 3/8" Drive Torque Wrench and 21 mm Socket
- 1 x Safety Block
- 2 x M24 (7/8") Collets
- 2 x M27 (1") Collets
- 1 x Instruction Manual
- 1 x Carry-Case with Protective Foam Inserts



Product Code: SG6TMSTD

SG6TM TECHNICAL DATA

Spreading force = 6 T (60 kN) per tool

It is recommended that tools are used in pairs positioned 180° apart, giving
2 x 6 = 12 T (120 kN)

The spreading force can be determined by pre-setting the torque wrench. The torque settings will produce a spreading force as set out below.

						Max.
Torque wrench setting	N/m	54	67	81	95	108
	ft/lb	40	50	60	70	80
Spreading force	T	2.8	3.5	4.5	5	6
	kN	28	35	45	50	60

Spreading distance = 0 - 80 mm (0 - 3.16")



5. SG11TM KIT COMPONENTS & TECHNICAL DATA

SG11TM KIT COMPONENTS

- 1 x SG11TM Tool
- 1 x 150 mm (6") Vernier Calliper
- 1 x ½" Drive Torque Wrench and 24 mm Socket
- 1 x Safety Block
- 2 x M30 (1 ⅛") Collets
- 2 x M33 (1 ¼") Collets
- 2 x M36 (1 ⅜") Collets
- 1 x Instruction Manual
- 1 x Carry-Case with Protective Foam Inserts



Product Code: SG11TMSTD

SG11TM TECHNICAL DATA

Spreading force = 11 T (110 kN) per tool

It is recommended that tools are used in pairs positioned 180° apart, giving
2 x 11 = 22 T (220 kN)

The spreading force can be determined by pre-setting the torque wrench. The torque settings will produce a spreading force as set out below.

						Max.
Torque wrench setting	N/m	40	60	80	100	120
	ft/lb	26	40	55	70	85
Spreading force	T	3.7	5.5	7.4	9.2	11
	kN	37	55	74	92	110

Spreading distance = 0 - 90 mm (0 - 3.55")



6. HOW THE SECURE-GRIP MECHANICAL TOOLS WORK

1. The two halves of the mechanical Secure-Grip tool are inserted into opposing flange bolt-holes

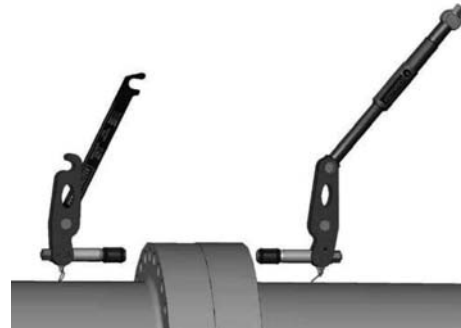

2. Both drive nuts are tightened locking the tool in to the flange bolt-holes

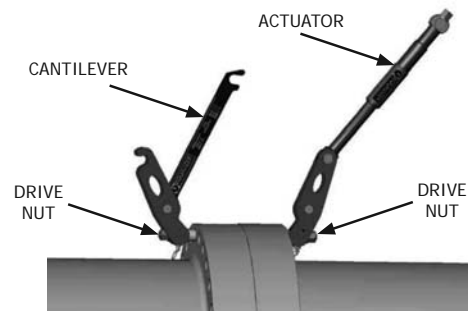

3. The cantilever followed by the actuator are swung and locked into position

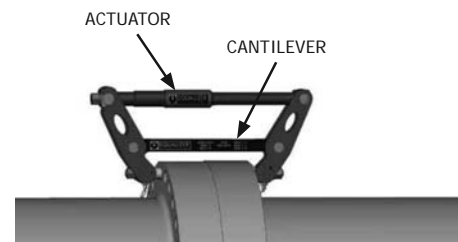

4. The actuator is tensioned spreading the flange to the maximum load capacity or maximum spreading distance of the tool





7. INSTALLATION AND OPERATION

7.1 COLLET SELECTION BASED ON FLANGE SPECIFICATION



It is important that the correct size of collet is used!
An undersized collet could allow the collet holder to pull through its bore!
An oversized collet has the potential to become jammed in the bolt-hole!

To select the applicable tool and collet for your flange please refer to the Secure-Grip application charts at the back of this manual (section 12, pages 26-35).

The Secure-Grip mechanical tools have a range of collets which are applicable to the following bolts and flange bolt-hole diameters:

Collet type	Minimum bolt-hole diameter	Maximum bolt-hole diameter	Metric coarse bolt	UNC bolt	Tool
M16 5/8"	17.5 mm / 0.69"	19.5 mm / 0.77"	M16	5/8"	SG4TM
M20 3/4"	20.5 mm / 0.81"	23 mm / 0.91"	M20	3/4"	SG4TM
M24 7/8"	24 mm / 0.94"	26.5 mm / 1.04"	M24	7/8"	SG6TM
M27 1"	27.5 mm / 1.1"	30 mm / 1.18"	M27	1"	SG6TM
M30 1 1/8"	30 mm / 1.18"	33 mm / 1.30"	M30	1 1/8"	SG11TM
M33 1 1/4"	32 mm / 1.26"	36 mm / 1.42"	M33	1 1/4"	SG11TM
M36 1 3/8"	35 mm / 1.38"	39 mm / 1.54"	M36	1 3/8"	SG11TM

If the specification of the flange is unknown then the vernier calliper supplied in the kit should be used to determine the correct collet as shown in the section 7.2, pages 9-11.



Important: The Secure-Grip collets are consumable items. The lifespan of a collet will vary depending on the flange materials with which it is used. To increase the lifespan of the collets it is recommended that they are flipped through 180 degrees on the collet holder, this will produce more even wear across the four ridges on the outer profile of the collet. See section 7.3 (page 12) for details on collet removal and replacement.



7.2 COLLET SELECTION BASED ON BOLT-HOLE MEASUREMENT



Note: It is important that the vernier calliper is held in the middle of the bolt-hole, and not held at an angle to the flange face, nor used on a bolt-hole which is worn, damaged or distorted, as these actions may result in the selection of an incorrect size of collet

1. To ensure a true measurement is taken, hold the vernier calliper:
 - square to the flange face
 - in the middle of the bolt-hole

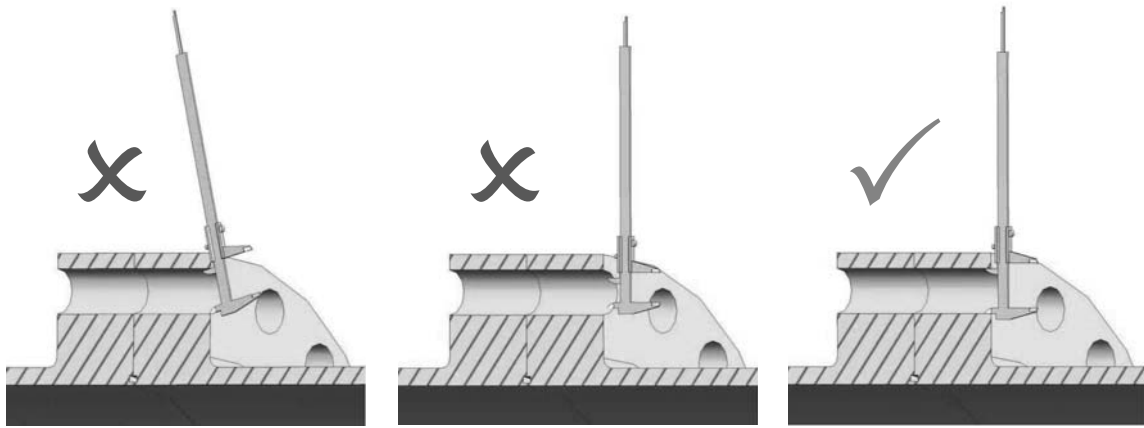

2. To determine whether the bolt-hole is round, take two separate measurements with the vernier calliper turned through 90° between measurements

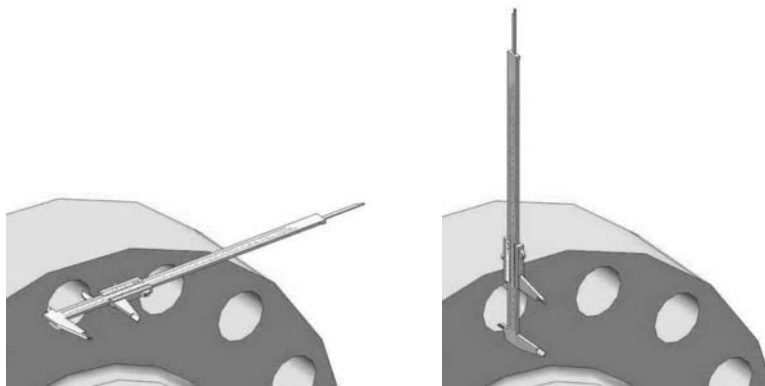



3. To read the measurement from the vernier calliper, scan along the desired scale from left to right. In this example, the major figure is 60mm, this is added to the minor figure of 8mm (indicated by where the vernier scale aligns with the main scale), giving a total measurement of 68mm.

With a bolt-hole size of 68mm, the operator can determine which collet and tool is appropriate to this flange by referring to the Secure-Grip Tool Range chart in section 11, page 25. For example: 68mm falls within the 63mm minimum and 69mm maximum bolt-hole sizes. Therefore collet identification is M64 / 2½" and the tool to be used is the SG18TE.

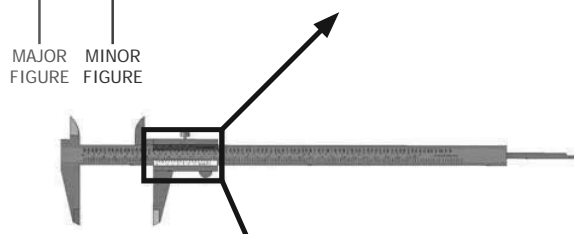
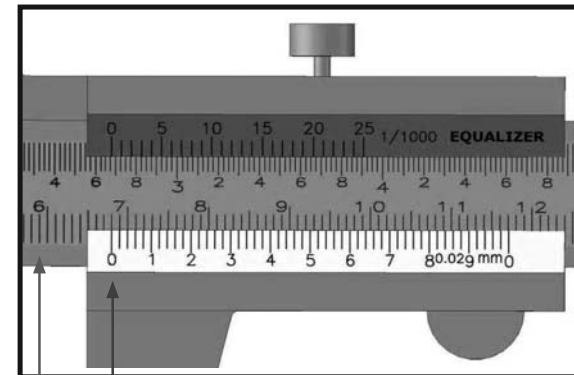

4. If the measurement contains fractions of a millimetre the method of reading the vernier calliper is slightly different. In this example, the major figure is 40mm (read in the same way as previously described). The minor figure is 7mm (read to the left of the zero). The fraction is 0.5mm (read from where the vernier scale lines up with the main scale). This gives a total measurement of 47.5mm.

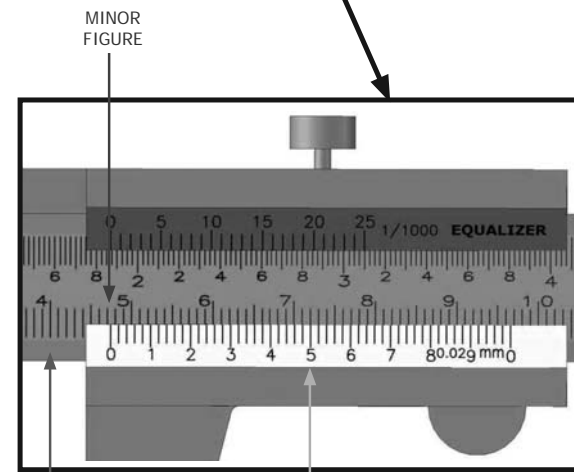



6. Each tool in the Secure-Grip range comes with the appropriate sizes of collets for that tool. If the collet labelling is worn or missing then the collet can be measured to ensure that the correct size is selected. An accurate measurement can only be obtained with the collet mounted on the collet holder. To do this:
- remove the collet head assembly from the tool and disassemble (see section 7.3, page 12 for details)
 - slide the collet over the collet holder
 - measure the centre section of the collet with the vernier calliper
 - identify the collet using the chart below, and select the correct size for the flange

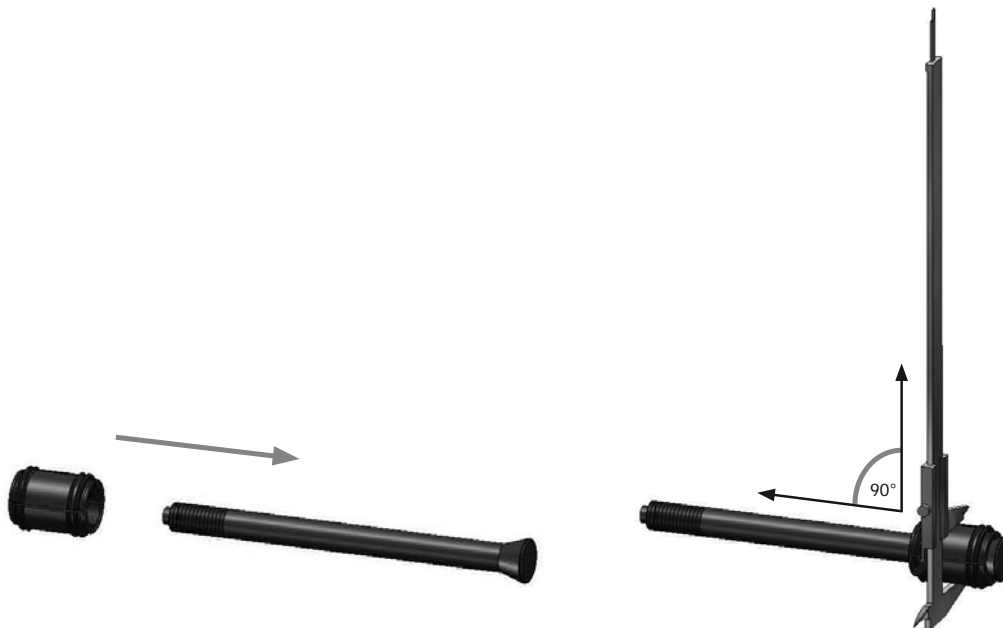

Centre section Ø	Collet type	Min. bolt-hole Ø	Max. bolt-hole Ø	Metric coarse bolt	UNC bolt
16 mm	M16 5/8"	17.5 mm / 0.69"	19.5 mm / 0.77"	M16	5/8"
19 mm	M20 3/4"	20.5 mm / 0.81"	23 mm / 0.91"	M20	3/4"
22.5 mm	M24 7/8"	24 mm / 0.94"	26.5 mm / 1.04"	M24	7/8"
25.5 mm	M27 1"	27.5 mm / 1.1"	30 mm / 1.18"	M27	1"
27 mm	M30 1 1/8"	30 mm / 1.18"	33 mm / 1.30"	M30	1 1/8"
29.5 mm	M33 1 1/4"	32 mm / 1.26"	36 mm / 1.42"	M33	1 1/4"
32.5 mm	M36 1 3/8"	35 mm / 1.38"	39 mm / 1.54"	M36	1 3/8"



7.3 COLLET REMOVAL AND REPLACEMENT

Once the correct collet has been selected it may be necessary to change the collet on the tool:

1. Place the tool on its side on a work bench or flat surface and unscrew and remove the drive nut



2. Pull the collet plunger ring out, and remove the collet head assembly from the tool

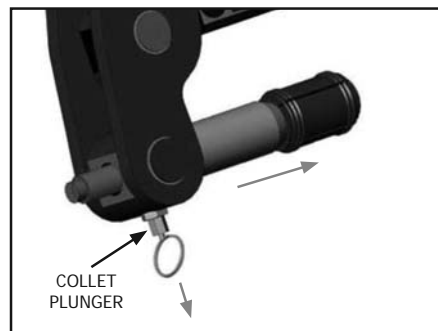

3. Slip the drive cone off the collet holder



4. Remove the collet from the collet holder and replace it with the correct collet for the flange to be separated

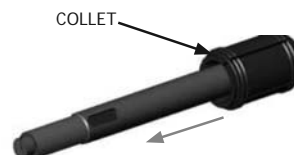

5. Reverse the above procedure to re-assemble the tool. Care should be taken to ensure the slot in the collet holder is aligned with the collet plunger



7.4 INSTALLATION AND OPERATION

Once the correct collet has been selected and mounted, tool operation can commence



Before attaching the tool ensure at least two flange bolts remain in place 180 degrees apart with nuts loosened sufficiently enough for flange work to be carried out. These bolts will reduce lateral flange movement during flange spreading.

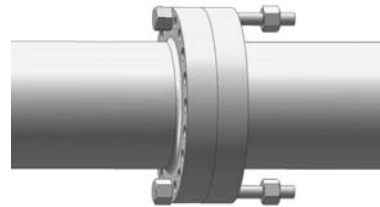

How to use the torque wrench

Balance the wrench in your left hand and unlock the knurled handle by turning the locking knob anti-clockwise. Set the torque amount by turning the knurled handle - see example 40-46 N/m

1. Turn the handle till 0 on fine scale reach 40 N/m on base scale
2. To set 46 turn handle till fine scale reach 6
3. Lock handle by turning the locking knob clockwise

Install the proper socket and attach to the tool. Pull handle till you feel and/or hear the wrench click. Setting of ft/lb scale is done in the same way as above.



Newton Scale (N/m)

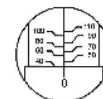

40 N/m

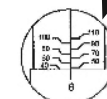

46 N/m
(1 on fine scale = 1 N/m)

Foot Pound (Ft.lb)

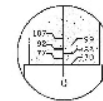

70 ft/lb

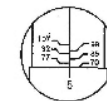

75 ft/lb
(1 on fine scale = 0.74 ft/lb)



Do not pull after the wrench clicks. Use special care at low torque settings. If the wrench has not been used for some time: operate it several times at low torque to allow internal lubricant to recoat. When not in use set to lowest torque setting. Don't turn handle below lowest torque setting. Your torque wrench is a precision measuring instrument and should be treated as such. Clean only by wiping, do not use any type of cleaner which may affect the special internal lubricant with which this wrench is packed at the factory.



1. Do not attempt to turn the grip while it is locked
2. Do not turn the grip more than one turn below the lowest scale reading or above the highest scale reading



1. Measure the thickness of the flange using the vernier calliper provided. Lock the calliper in position by tightening the locking screw

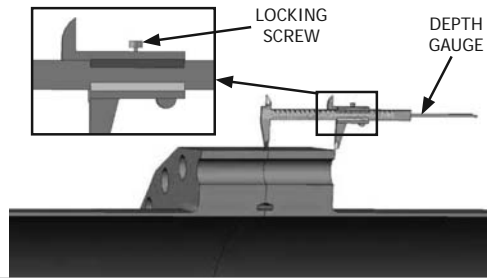

2. Select a suitable bolt-hole in which to attach the tool. Insert the depth gauge part of the vernier calliper into the bolt-hole keeping the base of the calliper flush with the bolting face of the flange

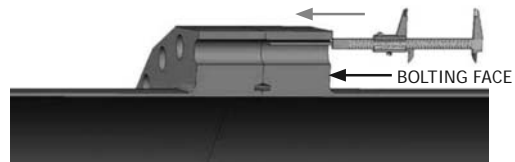

3. Insert the collet on the cantilever half of the tool into the opposite end of the same bolt-hole until it touches the end of the depth gauge (so that the collet is fully through one flange but not entering the other)

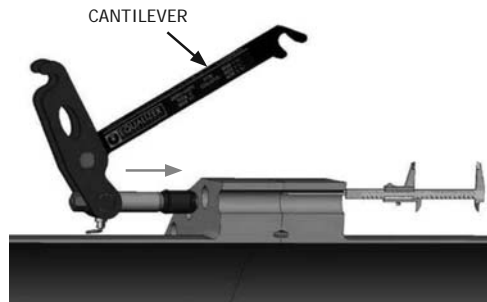

4. Set the torque wrench to 30 N/m (22 ft/lb) and tighten the drive nut until the torque wrench clicks. The cantilever half of the tool will now have a secure hold in the bolt-hole

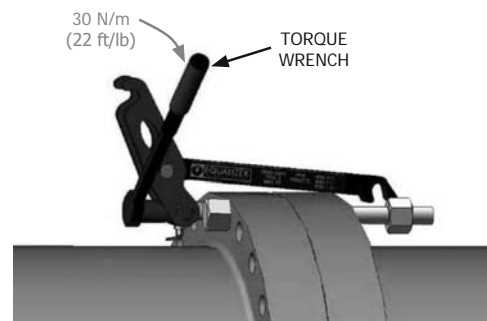



5. Insert the collet on the actuator half of the tool in to the bolt-hole until it touches the collet on the cantilever half of the tool, and tighten the drive nut with the torque wrench preset to 30 N/m (22 ft/lb) until it clicks. The actuator half of the tool will now have a secure hold in the bolt-hole

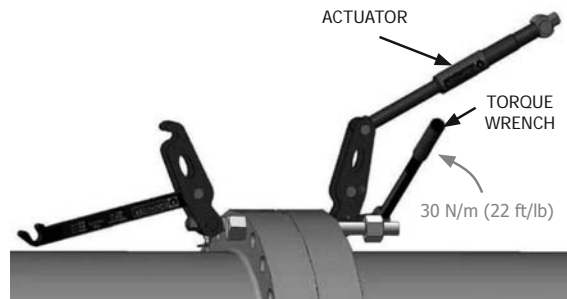

6. Rotate the cantilever into position hooking it over the cantilever pin in the actuator half of the tool. You will feel a click from the spring plunger when it is locked fully home



WARNING: operating the tool without the cantilever fully locked into position may result in personnel injury and damage to the tool

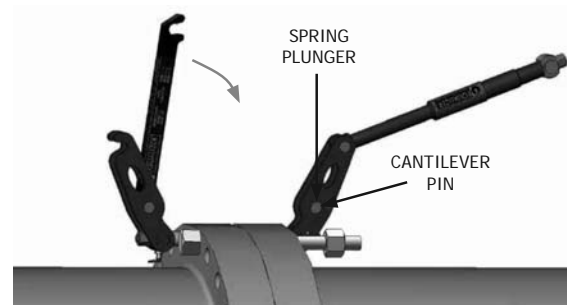

7. Ensure the actuator bolt is fully unscrewed then swing the actuator down into position

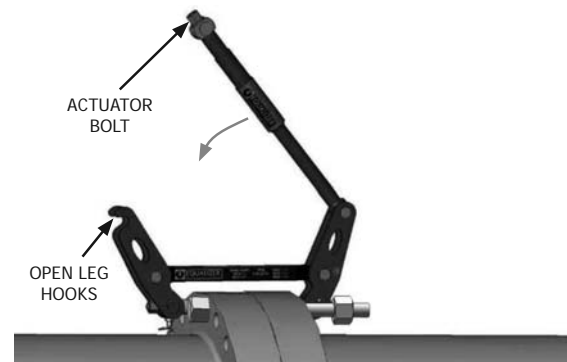

8. Tighten the actuator bolt until the lugs on the actuator union engage in the hooks on the open legs





9. Select the bolt-hole 180° opposite the tool you have just attached and repeat steps 2 to 8 for the second tool



Note: If more than two tools are being used they should be attached at an equal spacing around the flange joint

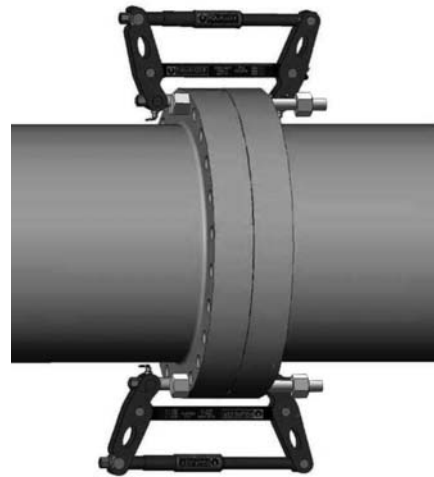

10. With the torque wrench set at 30 N/m (22 ft/lb) tighten the actuator bolt on one tool until the torque wrench clicks and then torque the actuator bolt on the other tool.

Continue tensioning the actuator bolts maintaining an equal tension in both tools until the flange spreads or the torque wrench clicks

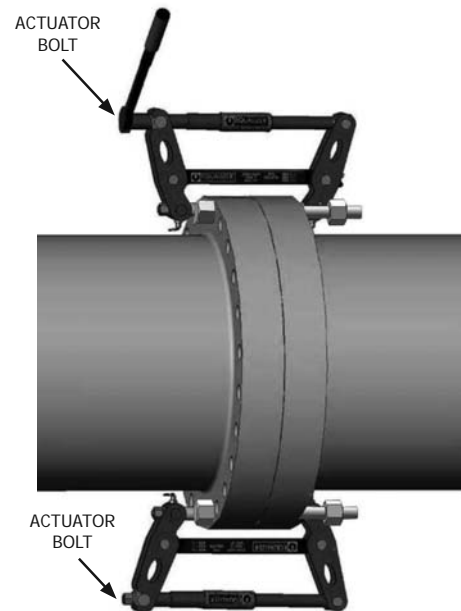



11. When the torque wrench clicks stop and increase the torque wrench setting by 10 N/m (6.5 ft/lb) then continue to tension both tools evenly until the flange spreads or the torque wrench clicks

If the torque wrench clicks continue increasing the torque wrench setting in 10 N/m (6.5 ft/lb) increments until the maximum for the tool has been reached (see table below)



If a greater spreading force is required then further tools can be added around the flange joint



WARNING: overloading the tool will cause tool failure which may result in injury to you and others around you

		SG4TM	SG6TM	SG11TM
Max. torque wrench setting	N/m	47	108	120
	ft/lb	35	80	85
Max. spreading force	T	3.7	6	11

12. Continue spreading the flange until the access gap required has been achieved or until the maximum tool travel has been reached



Important: the Secure-Grip mechanical tools are fitted with an internal mechanical stop which limits the travel. Forcing the tool to travel further will result in tool failure

TOOL	Max. distance
SG4TM	75 mm (2.95")
SG6TM	80 mm (3.15")
SG11TM	90 mm (3.5")

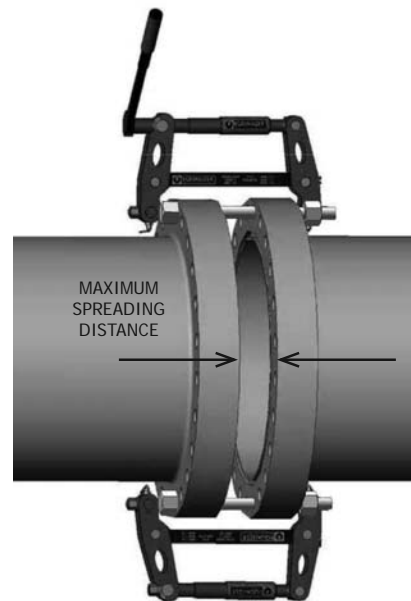



13. Once the flange has been separated and prior to any maintenance works the safety blocks must be inserted between the flanges. These are held in position by replacing two of the flange bolts.



WARNING: never place hands or fingers in a joint held by an activated tool

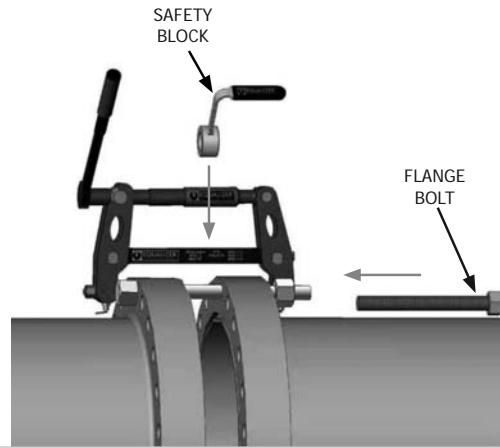

14. Following any maintenance works and prior to closing the flange joint, the safety blocks must be removed.

To reduce the load on each tool rotate the actuator bolt one full rotation. Repeat this on both tools in turn until the tools have no load on them and the joint is closed.

The tools can then be removed from the flange by reversing the installation procedure (steps 3 - 9)

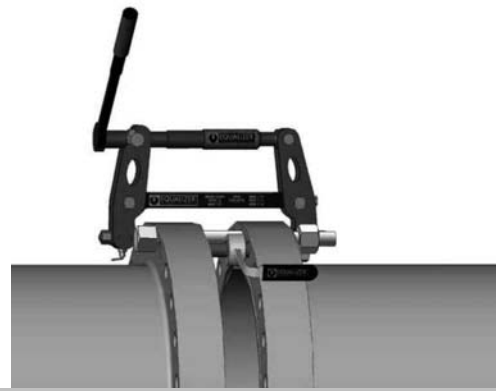



7.5 VALVE, SPADE OR BLIND REMOVAL, INSTALLATION AND OPERATION



The Secure-Grip mechanical tools are also ideal for the removal and insertion of blinds, spades and valves. Equalizer International can supply Short Collet Holder (SCH) Kits for each tool that will increase its relative stroke.

TOOL	Configuration	C ₁ (Closed)	C ₂ (Open)
SG4TM	standard tool (i)	0mm (0")	75mm (2.95")
	single SCH kit (ii)	42mm (1.65")	117mm (4.61")
	double SCH kit (iii)	84mm (3.31")	159mm (6.26")
SG6TM	standard tool (i)	0mm (0")	80mm (3.15")
	single SCH kit (ii)	60mm (1.42")	140mm (4.57")
	double SCH kit (iii)	120mm (4.72")	200mm (7.87")
SG11TM	standard tool (i)	0 mm (0")	90mm (3.50")
	single SCH kit (ii)	13mm (0.51")	103mm (4.06")
	double SCH kit (iii)	26mm (1.02")	116mm (4.57")

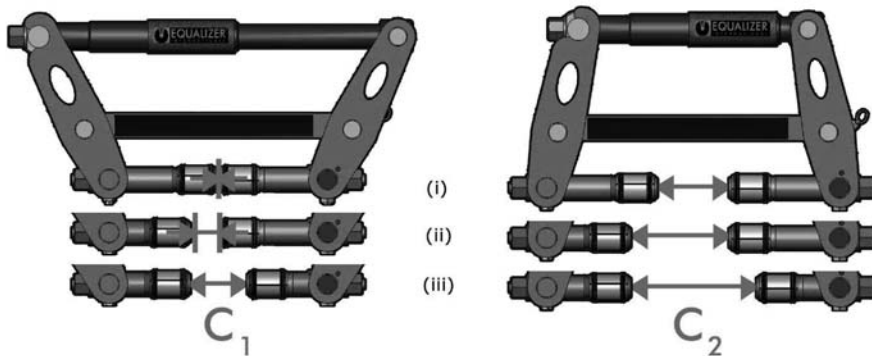

1. please refer to section 7.3 notes 1-4 for instruction on how to remove the standard collet holder and drive tube. The Short Collet Kit replaces one collet holders and drive cone, and is supplied with Collet fitted. The SG11TM Short Collet Kit comprises a pair of short collet holders and drive cones, but is not supplied with collets or springs.

2. Please follow section 7.4 for instruction on how to attach and activated the secure-grip mechanical tool.





7.6 SHORT COLLET HOLDER KIT CONTENTS

SG4TM SHORT COLLET HOLDER KIT - PART NUMBER: 610100-01		
ITEM No.	DESCRIPTION	QUANTITY
1	SHORT COLLET HOLDER	2
2	SHORT DRIVE CONE	2
3	M16 COLLET	1
4	M16 SPRING RING	2
5	M20 COLLET	1
6	M20 SPRING RING	2

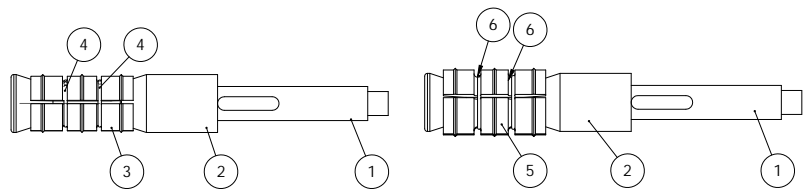

SG6TM SHORT COLLET HOLDER KIT - PART NUMBER: 620100-01		
ITEM No.	DESCRIPTION	QUANTITY
1	SHORT COLLET HOLDER	2
2	SHORT DRIVE CONE	2
3	M24 COLLET	1
4	M27 COLLET	1
5	M24 SPRING RING	2
6	M20 SPRING RING	2

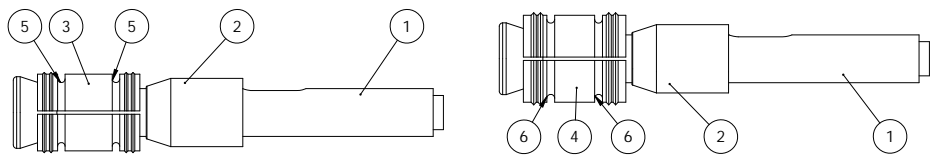

SG11TM SHORT COLLET HOLDER KIT - PART NUMBER: 630100-01		
ITEM No.	DESCRIPTION	QUANTITY
1	SHORT COLLET HOLDER	2
2	SHORT DRIVE CONE	2

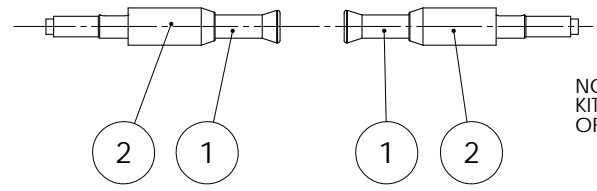

NOTE:
KIT CONTAINS 2x
OF EACH PART



8. MAINTENANCE AND LUBRICATION

On return from each job and before allocation against subsequent work the completeness of the Equalizer Secure-Grip mechanical tool kits must be established and items examined to ensure that they are serviceable.

At regular intervals and specifically after exposure to salt water Secure-Grip mechanical tools should be dismantled and lubricated as follows:

1. Lay the tool on a bench or flat surface with the right hand side face down



2. Remove the collet union, actuator and cantilever retaining rings. Care should be taken not to over-stretch the retaining rings during removal or replacement

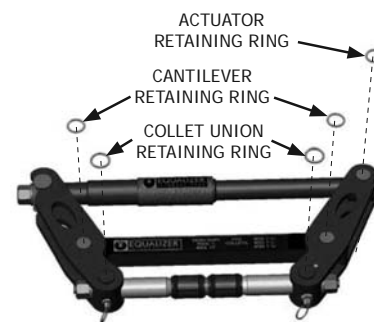

3. Remove the open leg l/h and closed leg l/h from the tool

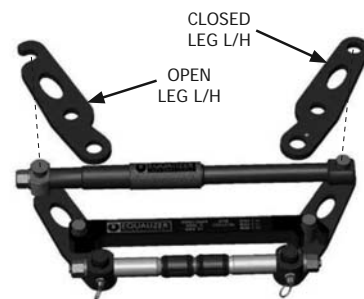

4. Remove the actuator and cantilever from the tool

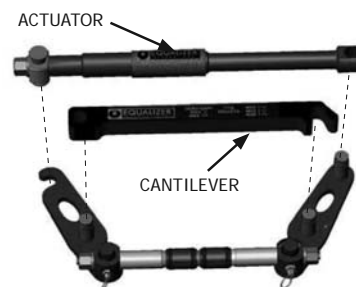



5. The left hand side of the tool can now be cleaned and lubricated. Care should be taken to ensure the centring springs do not jump out of their recess



Note: it is recommended that the tool is wiped down with a clean rag and WD40 or similar cleaning fluid to remove any dirt or grit and then liberally greased with a high load bearing grease (Rocol sapphire high load 2 or similar) in the areas shown

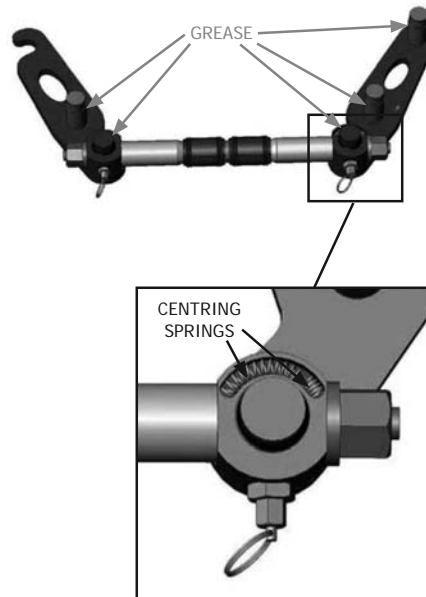

6. The tool can now be reassembled by reversing the dismantling procedure



Note: care should be taken to ensure the dowel protruding from the l/h closed leg of the tool is engaged between the two centring springs

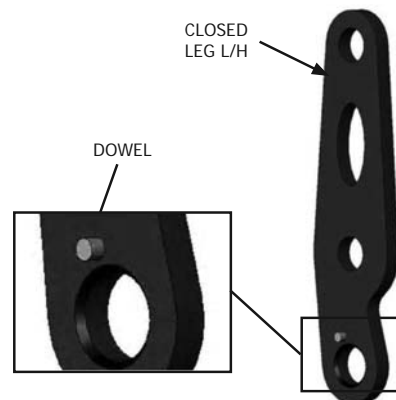

7. Once the tool is rebuilt, flip the tool over and repeat the above procedure with the other side of the tool



Following the cleaning and lubricating of the left and right hand sides of the tool the actuator can now be dismantled, cleaned and lubricated as follows:

- 8.** Remove the actuator sleeve retaining screw using a 2.5 mm allen key

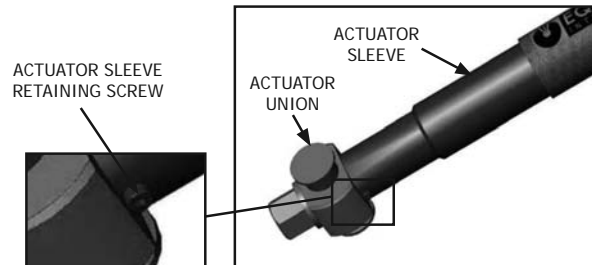

- 9.** Pull the actuator sleeve back - this will expose the actuator union retaining circlip. Expand the circlip with circlip pliers and slide it up the actuator bolt by about 50 mm (2")

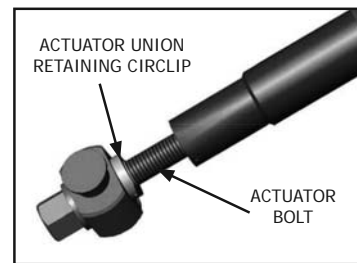

- 10.** SG11TM ONLY:
Slide the actuator union up the actuator bolt - this will expose the thrust washers and thrust race

Clean the thrust washers and thrust race with a clean cloth and WD40 (or similar cleaning fluid) to remove any grit or dirt. Liberally grease with a high load bearing grease (Rocol sapphire high load 2 or similar)

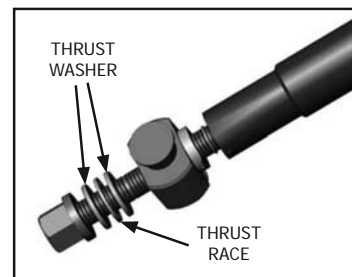

- 11.** The actuator is reassembled by reversing the dismantling procedure (steps 8-10)

- 12.** The collet head assembly is dismantled by following the procedure in section 7.3. The various components can then be cleaned and reassembled.



9. PARTS LISTS

SG4™ PARTS LIST

ITEM	PART No.	DESCRIPTION	QUANTITY
01	611501	CANTILEVER RETAINING RING*	10
02	611401	OPEN LEG R/H	01
03	611801	CLOSED LEG R/H	01
04		SEE ACTUATOR PARTS LIST	
05	612101	CANTILEVER	01
06	612001	CANTILEVER PLUNGER	01
07	611701	CANTILEVER PIN	03
08	611901	CLOSED LEG L/H	01
09		SEE COLLET HEAD PARTS LIST	
10	611301	OPEN LEG L/H	01

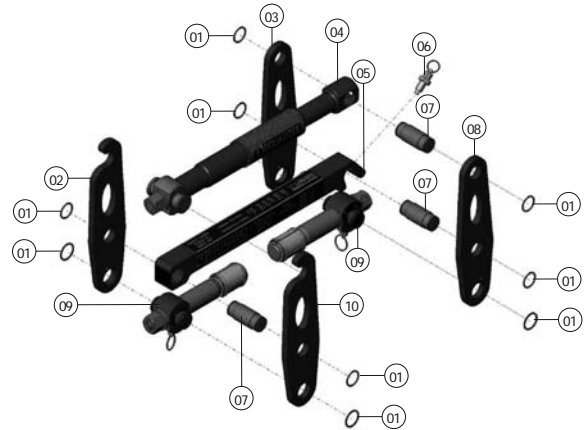

SG4™ COLLET HEAD PARTS LIST

ITEM	PART No.	DESCRIPTION	QUANTITY
01	610101	COLLET HOLDER	02
02	611001	M16 SPRING RING*	04
	611101	M20 SPRING RING*	04
03	610201	M16 COLLET*	02
	610301	M20 COLLET*	02
04	610501	DRIVE CONE	02
05	610601	COLLET UNION	02
06	610701	CENTRING SPRING 1	02
07	610801	COLLET NUT	02
08	900502	COLLET SPRING PLUNGER*	02

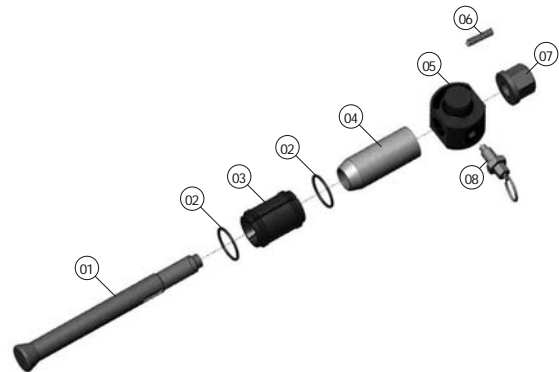

SG4™ ACTUATOR PARTS LIST

ITEM	PART No.	DESCRIPTION	QUANTITY
01	612201	ACTUATOR BOLT	01
02	612501	OPEN ACTUATOR UNION	01
03	401301	ACTUATOR RETAINING RING*	01
04	612701	ACTUATOR SLEEVE	01
05	612801	FOAM GRIP	01
06	612901	CLOSED ACTUATOR UNION	01
07	613001	ACTUATOR RETAINING BOLT	01

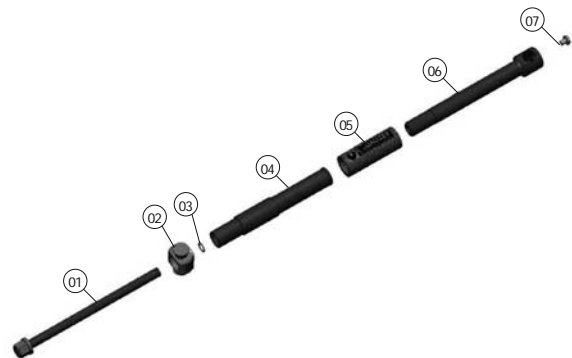



SG6TM PARTS LIST

ITEM	PART No.	DESCRIPTION	QUANTITY
01	621501	CANTILEVER RETAINING RING*	10
02	621401	OPEN LEG R/H	01
03	621801	CLOSED LEG R/H	01
04		SEE ACTUATOR PARTS LIST	
05	622101	CANTILEVER	01
06	632001	CANTILEVER PLUNGER	01
07	621701	CANTILEVER PIN	02
08	621901	CLOSED LEG L/H	01
09		SEE COLLET HEAD PARTS LIST	
10	621301	OPEN LEG L/H	01
11	632401	CANTILEVER SPACER	01
12	623501	CANTILEVER WASHER	01
13	623601	HOOK PIN	01

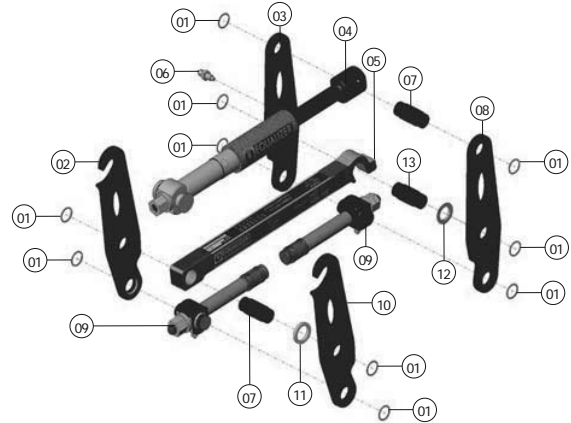

SG6TM COLLET HEAD PARTS LIST

ITEM	PART No.	DESCRIPTION	QUANTITY
01	620401	COLLET HOLDER	02
02	621001	M24 SPRING RING*	04
	621101	M27 SPRING RING*	04
03	620201	M24 COLLET*	02
	620301	M27 COLLET*	02
04	620501	DRIVE CONE	02
05	620601	COLLET UNION	02
06	620701	CENTRING SPRING 1	02
07	620801	COLLET NUT	02
08	632001	COLLET SPRING PLUNGER*	02

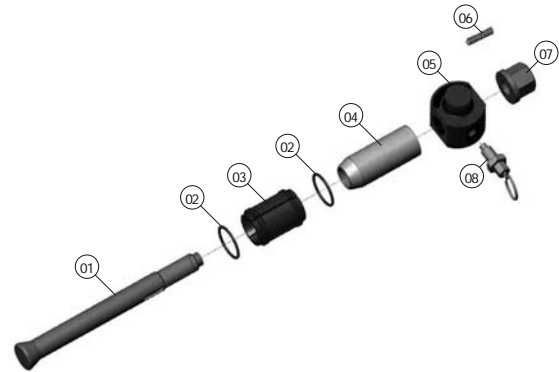

SG6TM ACTUATOR PARTS LIST

ITEM	PART No.	DESCRIPTION	QUANTITY
01	622201	ACTUATOR BOLT	01
02	622501	OPEN ACTUATOR UNION	01
03	623101	ACTUATOR RETAINING RING*	01
04	622701	ACTUATOR SLEEVE	01
05	622801	FOAM GRIP	01
06	622901	CLOSED ACTUATOR UNION	01
07	623001	ACTUATOR RETAINING BOLT	01

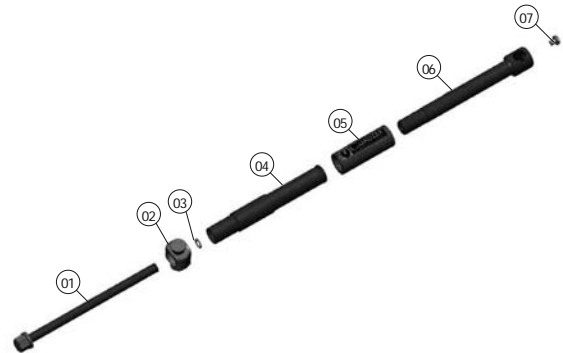



SG11TM PARTS LIST

ITEM	PART No.	DESCRIPTION	QUANTITY
01	631601	COLLET RETAINING RING*	04
02	631501	CANTILEVER RETAINING RING*	06
03	631401	OPEN LEG R/H	01
04	631901	CLOSED LEG R/H	01
05		SEE ACTUATOR PARTS LIST	
06	632101	CANTILEVER	01
07	632001	CANTILEVER PLUNGER	01
08	631701	CANTILEVER PIN	03
09	631801	CLOSED LEG L/H	01
10		SEE COLLET HEAD PARTS LIST	
11	631301	OPEN LEG L/H	01

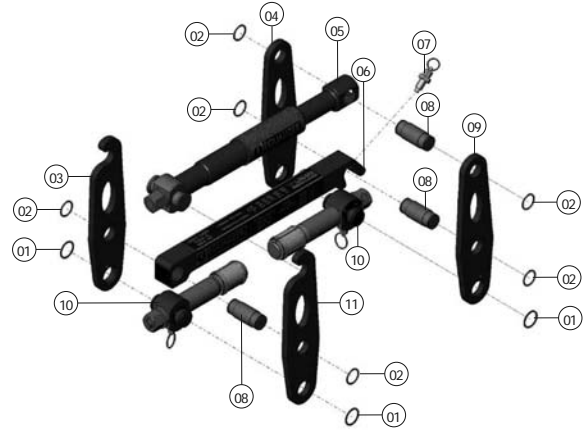

SG11TM COLLET HEAD PARTS LIST

ITEM	PART No.	DESCRIPTION	QUANTITY
01	630101	COLLET HOLDER	02
02	631001	M30 SPRING RING*	04
	631101	M33 SPRING RING*	04
	631201	M36 SPRING RING*	04
03	630201	M30 COLLET*	02
	630301	M33 COLLET*	02
	630401	M36 COLLET*	02
04	630501	DRIVE CONE	02
05	630601	COLLET UNION	02
06	630701	CENTRING SPRING 1	02
	633201	CENTRING SPRING 2	02
07	630801	COLLET NUT	02
08	900502	COLLET SPRING PLUNGER*	02

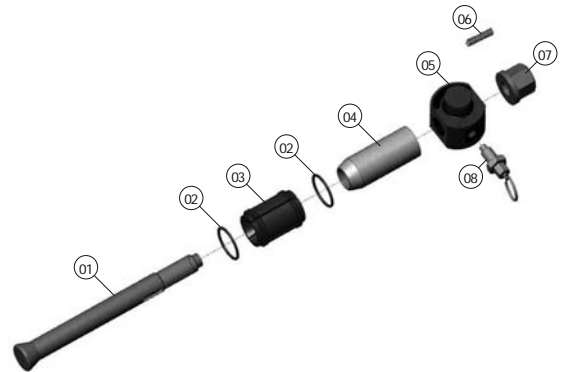

SG11TM ACTUATOR PARTS LIST

ITEM	PART No.	DESCRIPTION	QUANTITY
01	632201	ACTUATOR BOLT	01
02	632301	THRUST BEARING*	01
03	632501	OPEN ACTUATOR UNION	01
04	401301	ACTUATOR RETAINING RING*	01
05	632701	ACTUATOR SLEEVE	01
06	632801	FOAM GRIP	01
07	632901	CLOSED ACTUATOR UNION	01
08	633001	ACTUATOR RETAINING BOLT	01

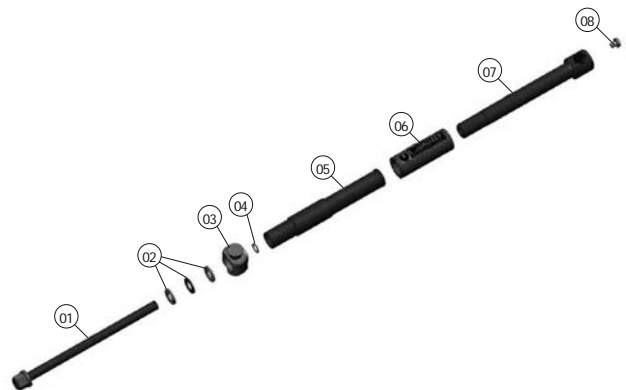



10. WEIGHTS AND DIMENSIONS

CLOSED TOOL DIMENSIONS

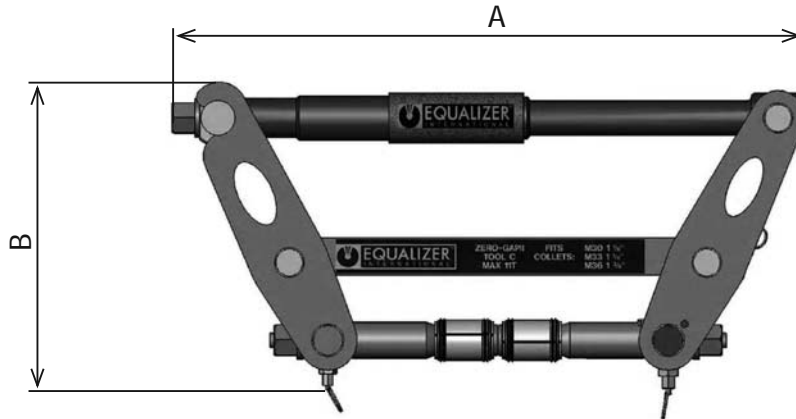

OPEN TOOL DIMENSIONS

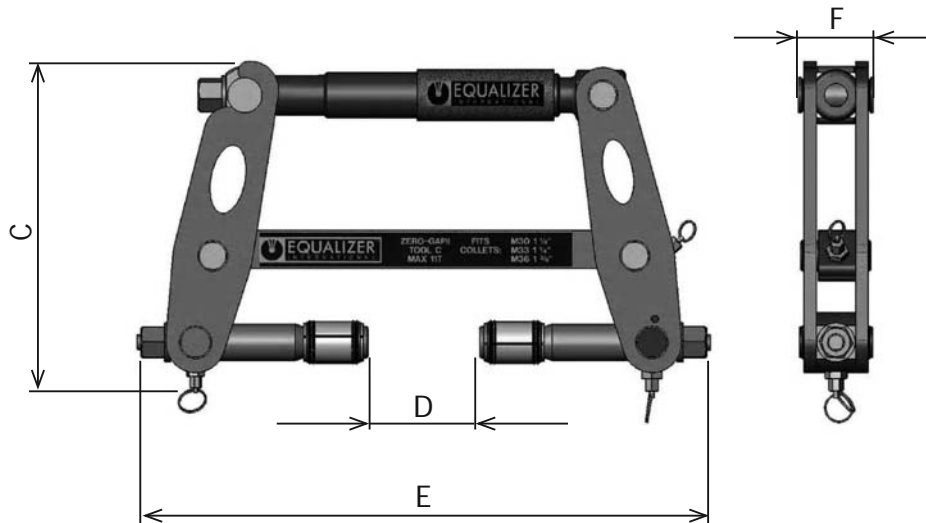

TOOL	A	B	C	D	E	F	TOOL WEIGHT	KIT WEIGHT
SG4™	398mm (15.67")	190mm (7.48")	190mm (7.48")	75mm (2.95")	385mm (15.16")	48mm (1.89")	4.5kg (10lbs)	13kg (28.5lbs)
SG6™	468mm (18.42")	245mm (9.65")	252mm (9.96")	80mm (3.15")	444mm (17.48")	52mm (2.05")	7.5kg (16.5lbs)	16kg (35 lbs)
SG11™	516mm (20.31")	250mm (9.84")	263mm (10.35")	90mm (3.55")	462mm (18.19")	60mm (2.36")	10.5kg (23.2lbs)	20kg (44 lbs)



11. TROUBLESHOOTING

Problem: The tools have been tensioned to their maximum torque value but the joint will not spread

- The pressure required to spread the joint is greater than that of the two tools you are using
- Add another one or two tools and distribute them equally around the joint (120° apart with 3 tools and 90° apart with 4 tools) and try again

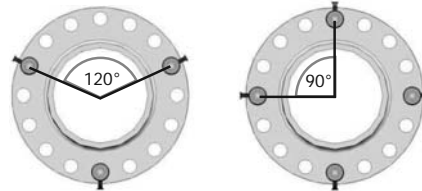

Problem: One collet is jammed in a bolt-hole

- A collet which is too small or large has been selected, or the collet has been inserted into a damaged or non-round bolt-hole
- Removal can be achieved as follows:

1. Pull the collet spring plunger ring out, and remove the rest of the tool, leaving the collet head assembly in the bolt hole
2. Unscrew the drive nut and remove the drive cone and collet cone
3. Screw the drive nut back onto the collet holder until it is 1-2mm off the end
4. Using a hammer and a suitable drift, move the collet holder until the drive nut is against the flange
5. Remove the drive nut and push the collet holder through the flange and out of the other end of the bolt-hole
6. Drive the collet out using the collet holder

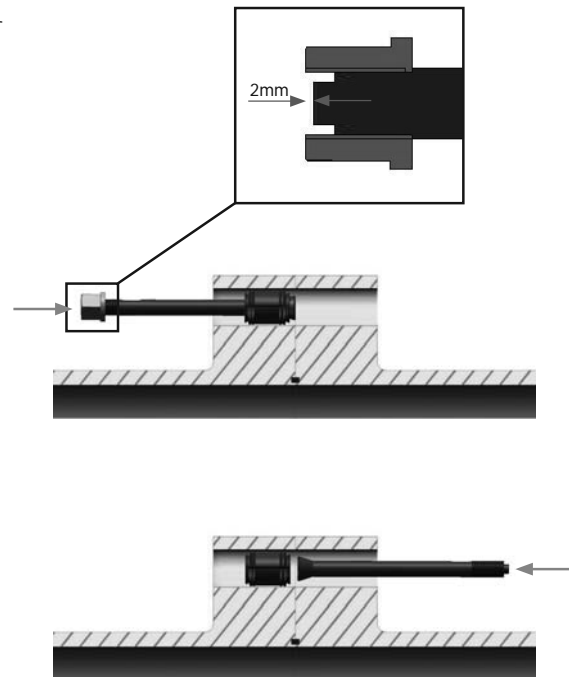



Problem: A pair of collets are jammed in a bolt-hole

↳ A collet which is too small or large has been selected, or the collet has been inserted into a damaged or non-round bolt-hole

➔ The flange must be spread before removal can be attempted. This can be done using another pair of Zero-Gap tools, or another method if available. Removal can then be achieved as follows:

1. On both sides, pull the collet spring plunger ring out, and remove the rest of the tool, leaving the collet head assemblies in the bolt-hole

2. On both sides, unscrew the drive nut and remove the drive cone and collet cone

3. On the left-hand side, screw the drive nut back onto the collet holder until it is 1-2mm off the end

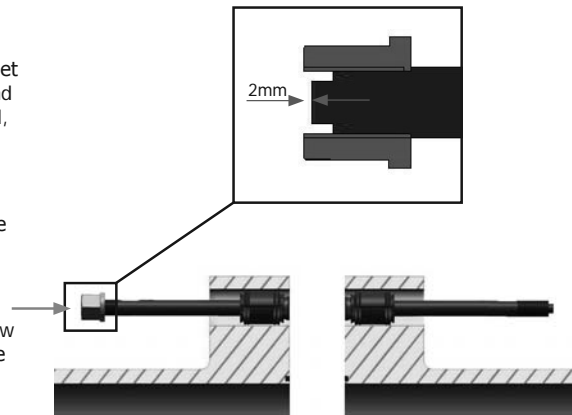

4. Using a hammer and a suitable drift, move the collet holder until it is possible to cut off the tapered end of the collet holder

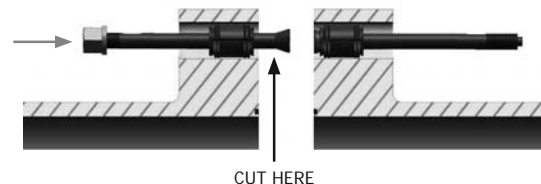

5. Cut off the tapered end with a hack saw or other cutting tool

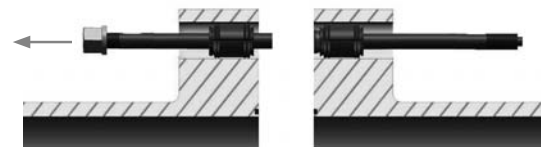

6. Withdraw the collet holder from the bolt-hole

7. Using a hammer and a suitable drift, move the collet holder on the right-hand side up to the left-hand side collet and drive it out



8. Drive the right-hand side collet out using the collet holder

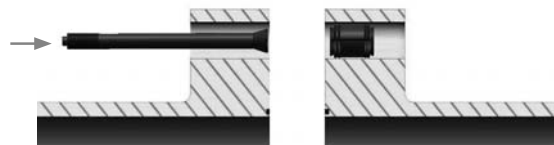



12. SECURE-GRIP TOOL RANGE

Collet identification	Tool type	Operation type	SWL (ton)	Min. bolt-hole diameter	Max. bolt-hole diameter
M16 5/8"	SG4TM	manual	4	17.5	19.5
M20 3/4"	SG4TM	manual	4	20.5	23
M24 7/8"	SG6TM	manual	6	24	26.5
M27 1"	SG6TM	manual	6	27.5	30
M30 1 1/8"	SG11TM	manual	11	30	33
M33 1 1/4"	SG11TM	manual	11	32	36
M36 1 3/8"	SG11TM	manual	11	35	39
M39 1 1/2"	SG13TE	hydraulic	13	38	42
M42 1 5/8"	SG13TE	hydraulic	13	41	45
M45 1 3/4"	SG13TE	hydraulic	13	44	49
M48 1 7/8"	SG15TE	hydraulic	15	47.5	52
M52 2"	SG15TE	hydraulic	15	50.5	56
M56 2 1/4"	SG15TE	hydraulic	15	55.5	62
M60	SG18TE	in-line hydraulic	18	59.5	63
M64 2 1/2"	SG18TE	in-line hydraulic	18	63	69
M70 2 3/4"	SG18TE	in-line hydraulic	18	69	75
M76 3"	SG25TE	in-line hydraulic	25	75	81
M80 3 1/4"	SG25TE	in-line hydraulic	25	79	86
M84	SG25TE	in-line hydraulic	25	83	88
M90 3 1/2"	SG25TE	in-line hydraulic	25	88	94
M95 3 3/4"	SG25TE	in-line hydraulic	25	94	101
M100 4"	SG25TE	in-line hydraulic	25	99	107



13. RANGE OF APPLICATION CHARTS

Use the charts on the following pages to determine which Secure-Grip tool (and which collet size) is suitable for a particular flange.

The charts are categorised as per flange type.

SPO		→	see page 29
ANSI	compact	→	see page 30
	orifice	→	see page 30
	reducing	→	see page 31
DIN	blind	→	see page 32
	threaded	→	see page 32
	weldneck	→	see page 33
	flat	→	see page 33
	lapped	→	see page 33
ASME	series A weld neck	→	see page 34
	series A lapped	→	see page 35
	series A socket welded	→	see page 35
	series B weld neck and blind	→	see page 35
API	6B weld neck	→	see page 36
	6B blind and threaded	→	see page 36
	6BX weld neck	→	see page 36
	6BX blind and test	→	see page 36
BS		→	see page 37



SPO

Nominal pipe size	Class															
	150		300		600		900		1500		2500		4500i			
	collet	tool	collet	tool	collet	tool	collet	tool	collet	tool	collet	tool	collet	tool		
1 1/2"														M16 5/8"	SG4TM	
2"														M16 5/8"	SG4TM	
2 1/2"														M20 3/4"	SG4TM	
3"														M20 3/4"	SG4TM	
4"														M16 5/8"	SG4TM	
5"														M24 7/8"	SG6TM	
6"														M27 1"	SG6TM	
8"														M30 1 1/8"	SG11TM	
10"														M30 1 1/8"	SG11TM	
12"														M39 1 1/2"	SG13TE	
14"														M48 1 7/8"	SG15TE	
16"	M16 5/8"	SG4TM	M20 3/4"	SG4TM	M27 1"	SG6TM	M30 1 1/8"	SG11TM	M33 1 1/4"	SG11TM	M45 1 3/4"	SG13TE	M60	SG18TE	M60	SG18TE
18"	M16 5/8"	SG4TM	M20 3/4"	SG4TM	M30 1 1/8"	SG11TM	M33 1 1/4"	SG11TM	M45 1 3/4"	SG13TE	M60	SG18TE	M60	SG18TE	M64 2 1/2"	SG18TE
20"	M16 5/8"	SG4TM	M24 7/8"	SG6TM	M30 1 1/8"	SG11TM	M36 1 3/8"	SG11TM	M48 1 7/8"	SG15TE	M64 2 1/2"	SG18TE	M84	SG25TE	M84	SG25TE
22"	M16 5/8"	SG4TM	M24 7/8"	SG6TM	M33 1 1/4"	SG11TM	M39 1 1/2"	SG13TE	M52 2"	SG15TE	M76 3"	SG25TE	M90 3 1/2"	SG25TE	M90 3 1/2"	SG25TE
24"	M20 3/4"	SG4TM	M27 1"	SG6TM	M33 1 1/4"	SG11TM	M42 1 5/8"	SG13TE	M60	SG18TE	M84	SG25TE	M100 4"	SG25TE	M100 4"	SG25TE
26"	M20 3/4"	SG4TM	M27 1"	SG6TM	M33 1 1/4"	SG11TM	M45 1 3/4"	SG13TE	M60	SG18TE						
28"	M20 3/4"	SG4TM	M27 1"	SG6TM	M36 1 3/8"	SG11TM	M45 1 3/4"	SG13TE	M60	SG18TE						
30"	M20 3/4"	SG4TM	M30 1 1/8"	SG11TM	M36 1 3/8"	SG11TM	M48 1 7/8"	SG15TE	M64 2 1/2"	SG18TE						
32"	M20 3/4"	SG4TM	M30 1 1/8"	SG11TM	M39 1 1/2"	SG13TE	M52 2"	SG15TE	M64 2 1/2"	SG18TE						
34"	M20 3/4"	SG4TM	M33 1 1/4"	SG11TM	M39 1 1/2"	SG13TE	M60	SG18TE	M70 2 3/4"	SG18TE						
36"	M24 7/8"	SG6TM	M33 1 1/4"	SG11TM	M39 1 1/2"	SG13TE	M60	SG18TE	M84	SG25TE						
38"	M24 7/8"	SG6TM	M33 1 1/4"	SG11TM	M39 1 1/2"	SG13TE	M64 2 1/2"	SG18TE	M90 3 1/2"	SG25TE						
40"	M24 7/8"	SG6TM	M33 1 1/4"	SG11TM	M39 1 1/2"	SG13TE	M64 2 1/2"	SG18TE	M84	SG25TE						
42"	M24 7/8"	SG6TM	M36 1 3/8"	SG11TM	M48 1 7/8"	SG15TE	M64 2 1/2"	SG18TE	M95 3 3/4"	SG25TE						
44"	M24 7/8"	SG6TM	M36 1 3/8"	SG11TM	M48 1 7/8"	SG15TE	M64 2 1/2"	SG18TE	M95 3 3/4"	SG25TE						
46"	M24 7/8"	SG6TM	M39 1 1/2"	SG13TE	M48 1 7/8"	SG15TE	M70 2 3/4"	SG18TE	M95 3 3/4"	SG25TE						
48"	M24 7/8"	SG6TM	M39 1 1/2"	SG13TE	M48 1 7/8"	SG15TE	M76 3"	SG25TE	M95 3 3/4"	SG25TE						



ANSI compact

Nominal pipe size	Class									
	300		600		900		1500		2500	
	collet	tool	collet	tool	collet	tool	collet	tool	collet	tool
1"	no flange		no flange		no flange		no flange		no flange	
1 1/2"										
2"									M16 5/8"	SG4TM
2 1/2"	M16 5/8"	SG4TM	M16 5/8"	SG4TM	M16 5/8"	SG4TM	M16 5/8"	SG4TM	M24 7/8"	SG6TM
3"	M16 5/8"	SG4TM	M16 5/8"	SG4TM	M16 5/8"	SG4TM	M16 5/8"	SG4TM	M16 5/8"	SG4TM
4"	M20 3/4"	SG4TM	M20 3/4"	SG4TM	M20 3/4"	SG4TM	M20 3/4"	SG4TM	M20 3/4"	SG4TM
5"	M20 3/4"	SG4TM	M20 3/4"	SG4TM	M20 3/4"	SG4TM	M20 3/4"	SG4TM	M27 1"	SG6TM
6"	M20 3/4"	SG4TM	M20 3/4"	SG4TM	M20 3/4"	SG4TM	M24 7/8"	SG6TM	M30 1 1/8"	SG11TM
8"	M20 3/4"	SG4TM	M20 3/4"	SG4TM	M20 3/4"	SG4TM	M27 1"	SG6TM	M36 1 3/8"	SG11TM
10"	M20 3/4"	SG4TM	M20 3/4"	SG4TM	M27 1"	SG6TM	M30 1 1/8"	SG11TM	M45 1 3/4"	SG13TE
12"	M20 3/4"	SG4TM	M24 7/8"	SG6TM	M30 1 1/8"	SG11TM	M36 1 3/8"	SG11TM	M52 2"	SG15TE
14"	M20 3/4"	SG4TM	M27 1"	SG6TM	M33 1 1/4"	SG11TM	M36 1 3/8"	SG11TM	M45 1 3/4"	SG13TE
16"	M20 3/4"	SG4TM	M30 1 1/8"	SG11TM	M36 1 3/8"	SG11TM	M42 1 5/8"	SG13TE	M52 2"	SG15TE
18"	M24 7/8"	SG6TM	M33 1 1/4"	SG11TM	M36 1 3/8"	SG11TM	M45 1 3/4"	SG13TE	M56 2 1/4"	SG15TE
20"	M30 1 1/8"	SG11TM	M36 1 3/8"	SG11TM	M39 1 1/2"	SG13TE	M52 2"	SG15TE	M64 2 1/2"	SG18TE
24"	M30 1 1/8"	SG11TM	M39 1 1/2"	SG13TE	M45 1 3/4"	SG13TE	M56 2 1/4"	SG15TE	M64 2 1/2"	SG18TE
30"	M27 1"	SG6TM	M42 1 5/8"	SG13TE	M56 2 1/4"	SG15TE	M70 2 3/4"	SG18TE		
36"	M30 1 1/8"	SG11TM	M45 1 3/4"	SG13TE	M56 2 1/4"	SG15TE	M76 3"	SG25TE		
40"	M30 1 1/8"	SG11TM	M52 2"	SG15TE	M64 2 1/2"	SG18TE	M84	SG25TE		

ANSI orifice

Nominal pipe size	Class											
	300		400		600		900		1500		2500	
	collet	tool	collet	tool	collet	tool	collet	tool	collet	tool		
1"	M16 5/8"	SG4TM	M16 5/8"	SG4TM	M16 5/8"	SG4TM	M24 7/8"	SG6TM	M24 7/8"	SG6TM	M24 7/8"	SG6TM
1 1/2"	M20 3/4"	SG4TM	M20 3/4"	SG4TM	M20 3/4"	SG4TM	M27 1"	SG6TM	M27 1"	SG6TM	M30 1 1/8"	SG11TM
2"	M16 5/8"	SG4TM	M16 5/8"	SG4TM	M16 5/8"	SG4TM	M24 7/8"	SG6TM	M24 7/8"	SG6TM	M27 1"	SG6TM
2 1/2"	M20 3/4"	SG4TM	M20 3/4"	SG4TM	M20 3/4"	SG4TM	M27 1"	SG6TM	M27 1"	SG6TM	M30 1 1/8"	SG11TM
3"	M20 3/4"	SG4TM	M20 3/4"	SG4TM	M20 3/4"	SG4TM	M24 7/8"	SG6TM	M30 1 1/8"	SG11TM	M33 1 1/4"	SG11TM
4"	M20 3/4"	SG4TM	M24 7/8"	SG6TM	M24 7/8"	SG6TM	M30 1 1/8"	SG11TM	M33 1 1/4"	SG11TM	M39 1 1/2"	SG13TE
6"	M20 3/4"	SG4TM	M24 7/8"	SG6TM	M27 1"	SG6TM	M30 1 1/8"	SG11TM	M36 1 3/8"	SG11TM	M52 2"	SG15TE
8"	M24 7/8"	SG6TM	M27 1"	SG6TM	M30 1 1/8"	SG11TM	M36 1 3/8"	SG11TM	M42 1 5/8"	SG13TE	M52 2"	SG15TE
10"	M27 1"	SG6TM	M30 1 1/8"	SG11TM	M33 1 1/4"	SG11TM	M36 1 3/8"	SG11TM	M48 1 7/8"	SG15TE	M64 2 1/2"	SG18TE
12"	M30 1 1/8"	SG11TM	M33 1 1/4"	SG11TM	M33 1 1/4"	SG11TM	M36 1 3/8"	SG11TM	M52 2"	SG15TE	M70 2 3/4"	SG18TE
14"	M30 1 1/8"	SG11TM	M33 1 1/4"	SG11TM	M36 1 3/8"	SG11TM	M39 1 1/2"	SG13TE	M56 2 1/4"	SG15TE		
16"	M33 1 1/4"	SG11TM	M36 1 3/8"	SG11TM	M39 1 1/2"	SG13TE	M42 1 5/8"	SG13TE	M64 2 1/2"	SG18TE		
18"	M33 1 1/4"	SG11TM	M36 1 3/8"	SG11TM	M42 1 5/8"	SG13TE	M48 1 7/8"	SG15TE	M70 2 3/4"	SG18TE		
20"	M33 1 1/4"	SG11TM	M39 1 1/2"	SG13TE	M42 1 5/8"	SG13TE	M52 2"	SG15TE	M76 3"	SG25TE		
24"	M39 1 1/2"	SG13TE	M45 1 3/4"	SG13TE	M48 1 7/8"	SG15TE	M64 2 1/2"	SG18TE	M90 3 1/2"	SG25TE		



ANSI reducing

Nominal pipe size	Class													
	150		300		400		600		900		1500		2500	
	collet	tool	collet	tool	collet	tool	collet	tool	collet	tool	collet	tool	collet	tool
1/2"									M20 3/4"	SG4TM	M20 3/4"	SG4TM	M20 3/4"	SG4TM
3/4"			M16 5/8"	SG4TM	M16 5/8"	SG4TM	M16 5/8"	SG4TM	M20 3/4"	SG4TM	M20 3/4"	SG4TM	M20 3/4"	SG4TM
1"			M16 5/8"	SG4TM	M16 5/8"	SG4TM	M16 5/8"	SG4TM	M24 7/8"	SG6TM	M24 7/8"	SG6TM	M24 7/8"	SG6TM
1 1/4"			M16 5/8"	SG4TM	M16 5/8"	SG4TM	M16 5/8"	SG4TM	M24 7/8"	SG6TM	M24 7/8"	SG6TM	M27 1"	SG6TM
1 1/2"			M20 3/4"	SG4TM	M20 3/4"	SG4TM	M20 3/4"	SG4TM	M27 1"	SG6TM	M27 1"	SG6TM	M30 1 1/8"	SG11TM
2"	M16 5/8"	SG4TM	M16 5/8"	SG4TM	M16 5/8"	SG4TM	M16 5/8"	SG4TM	M24 7/8"	SG6TM	M24 7/8"	SG6TM	M27 1"	SG6TM
2 1/2"	M16 5/8"	SG4TM	M20 3/4"	SG4TM	M20 3/4"	SG4TM	M20 3/4"	SG4TM	M27 1"	SG6TM	M27 1"	SG6TM	M30 1 1/8"	SG11TM
3"	M16 5/8"	SG4TM	M20 3/4"	SG4TM	M20 3/4"	SG4TM	M20 3/4"	SG4TM	M24 7/8"	SG6TM	M30 1 1/8"	SG11TM	M33 1 1/4"	SG11TM
3 1/2"	M16 5/8"	SG4TM	M20 3/4"	SG4TM	M24 7/8"	SG6TM	M24 7/8"	SG6TM	no flange		no flange		no flange	
4"	M16 5/8"	SG4TM	M20 3/4"	SG4TM	M24 7/8"	SG6TM	M24 7/8"	SG6TM	M30 1 1/8"	SG11TM	M33 1 1/4"	SG11TM	M39 1 1/2"	SG13TE
5"	M20 3/4"	SG4TM	M20 3/4"	SG4TM	M24 7/8"	SG6TM	M27 1"	SG6TM	M33 1 1/4"	SG11TM	M39 1 1/2"	SG13TE	M45 1 3/4"	SG13TE
6"	M20 3/4"	SG4TM	M20 3/4"	SG4TM	M24 7/8"	SG6TM	M27 1"	SG6TM	M30 1 1/8"	SG11TM	M36 1 3/8"	SG11TM	M52 2"	SG15TE
8"	M20 3/4"	SG4TM	M24 7/8"	SG6TM	M27 1"	SG6TM	M30 1 1/8"	SG11TM	M36 1 3/8"	SG11TM	M42 1 5/8"	SG13TE	M52 2"	SG15TE
10"	M24 7/8"	SG6TM	M27 1"	SG6TM	M30 1 1/8"	SG11TM	M33 1 1/4"	SG11TM	M36 1 3/8"	SG11TM	M48 1 7/8"	SG15TE	M64 2 1/2"	SG18TE
12"	M24 7/8"	SG6TM	M30 1 1/8"	SG11TM	M33 1 1/4"	SG11TM	M33 1 1/4"	SG11TM	M36 1 3/8"	SG11TM	M52 2"	SG15TE	M70 2 3/4"	SG18TE
14"	M27 1"	SG6TM	M30 1 1/8"	SG11TM	M33 1 1/4"	SG11TM	M36 1 3/8"	SG11TM	M39 1 1/2"	SG13TE	M56 2 1/4"	SG15TE		
16"	M27 1"	SG6TM	M33 1 1/4"	SG11TM	M36 1 3/8"	SG11TM	M39 1 1/2"	SG13TE	M42 1 5/8"	SG13TE	M64 2 1/2"	SG18TE		
18"	M30 1 1/8"	SG11TM	M33 1 1/4"	SG11TM	M36 1 3/8"	SG11TM	M42 1 5/8"	SG13TE	M48 1 7/8"	SG15TE	M70 2 3/4"	SG18TE		
20"	M30 1 1/8"	SG11TM	M33 1 1/4"	SG11TM	M39 1 1/2"	SG13TE	M42 1 5/8"	SG13TE	M52 2"	SG15TE	M76 3"	SG25TE		
22"	no flange		no flange		no flange		no flange		no flange		no flange			
24"	M33 1 1/4"	SG11TM	M39 1 1/2"	SG13TE	M45 1 3/4"	SG13TE	M48 1 7/8"	SG15TE	M64 2 1/2"	SG18TE	M90 3 1/2"	SG25TE		
26"	M33 1 1/4"	SG11TM	M42 1 5/8"	SG13TE	M42 1 5/8"	SG13TE	M48 1 7/8"	SG15TE	M70 2 3/4"	SG18TE				
28"	M33 1 1/4"	SG11TM	M42 1 5/8"	SG13TE	M42 1 5/8"	SG13TE	M52 2"	SG15TE	M76 3"	SG25TE				
30"	M33 1 1/4"	SG11TM	M45 1 3/4"	SG13TE	M45 1 3/4"	SG13TE	M56 2 1/4"	SG15TE	M76 3"	SG25TE				
32"	M39 1 1/2"	SG13TE	M48 1 7/8"	SG15TE	M48 1 7/8"	SG15TE	M56 2 1/4"	SG15TE	M84	SG25TE				
34"	M39 1 1/2"	SG13TE	M48 1 7/8"	SG15TE	M48 1 7/8"	SG15TE	M56 2 1/4"	SG15TE	M90 3 1/2"	SG25TE				
36"	M39 1 1/2"	SG13TE	M52 2"	SG15TE	M52 2"	SG15TE	M56 2 1/4"	SG15TE	M90 3 1/2"	SG25TE				
38"	M39 1 1/2"	SG13TE	M39 1 1/2"	SG13TE	M39 1 1/2"	SG13TE	M56 2 1/4"	SG15TE	M90 3 1/2"	SG25TE				
40"	M39 1 1/2"	SG13TE	M42 1 5/8"	SG13TE	M42 1 5/8"	SG13TE	M56 2 1/4"	SG15TE	M90 3 1/2"	SG25TE				
42"	M39 1 1/2"	SG13TE	M42 1 5/8"	SG13TE	M42 1 5/8"	SG13TE	M56 2 1/4"	SG15TE	M90 3 1/2"	SG25TE				
44"	M39 1 1/2"	SG13TE	M45 1 3/4"	SG13TE	M45 1 3/4"	SG13TE	M56 2 1/4"	SG15TE	M95 3 3/4"	SG25TE				
46"	M39 1 1/2"	SG13TE	M48 1 7/8"	SG15TE	M48 1 7/8"	SG15TE	M56 2 1/4"	SG15TE	M100 4"	SG25TE				
48"	M39 1 1/2"	SG13TE	M48 1 7/8"	SG15TE	M48 1 7/8"	SG15TE	M70 2 3/4"	SG18TE	M100 4"	SG25TE				



DIN blind

Nominal pipe size	Class									
	PN16		PN25		PN40		PN64		PN100	
	collet	tool	collet	tool	collet	tool	collet	tool	collet	tool
3/4"									no flange	no flange
1"							M16 5/8"	SG4TM	M16 5/8"	SG4TM
1 1/4"	M16 5/8"	SG4TM	M16 5/8"	SG4TM	M16 5/8"	SG4TM	M20 3/4"	SG4TM	M20 3/4"	SG4TM
1 1/2"	M16 5/8"	SG4TM	M16 5/8"	SG4TM	M16 5/8"	SG4TM	M20 3/4"	SG4TM	M20 3/4"	SG4TM
2"	M16 5/8"	SG4TM	M16 5/8"	SG4TM	M16 5/8"	SG4TM	M20 3/4"	SG4TM	M24 7/8"	SG6TM
2 1/2"	M16 5/8"	SG4TM	M16 5/8"	SG4TM	M16 5/8"	SG4TM	M20 3/4"	SG4TM	M24 7/8"	SG6TM
3"	M16 5/8"	SG4TM	M16 5/8"	SG4TM	M16 5/8"	SG4TM	M20 3/4"	SG4TM	M24 7/8"	SG6TM
4"	M16 5/8"	SG4TM	M20 3/4"	SG4TM	M20 3/4"	SG4TM	M24 7/8"	SG6TM	M27 1"	SG6TM
5"	M16 5/8"	SG4TM	M24 7/8"	SG6TM	M24 7/8"	SG6TM	M27 1"	SG6TM	M30 1 1/8"	SG11TM
6"	M20 3/4"	SG4TM	M24 7/8"	SG6TM	M24 7/8"	SG6TM	M30 1 1/8"	SG11TM	M30 1 1/8"	SG11TM
7"	M20 3/4"	SG4TM	M24 7/8"	SG6TM	M27 1"	SG6TM	M30 1 1/8"	SG11TM	M30 1 1/8"	SG11TM
8"	M20 3/4"	SG4TM	M24 7/8"	SG6TM	M27 1"	SG6TM	M33 1 1/4"	SG11TM	M33 1 1/4"	SG11TM
10"	M24 7/8"	SG6TM	M27 1"	SG6TM	M30 1 1/8"	SG11TM	M33 1 1/4"	SG11TM	M36 1 3/8"	SG11TM
12"	M24 7/8"	SG6TM	M27 1"	SG6TM	M30 1 1/8"	SG11TM	M33 1 1/4"	SG11TM	M39 1 1/2"	SG13TE
14"	M24 7/8"	SG6TM	M30 1 1/8"	SG11TM	M33 1 1/4"	SG11TM	M36 1 3/8"	SG11TM	M45 1 3/4"	SG13TE
16"	M27 1"	SG6TM	M33 1 1/4"	SG11TM	M36 1 3/8"	SG11TM	M39 1 1/2"	SG13TE		
20"	M30 1 1/8"	SG11TM	M33 1 1/4"	SG11TM	M39 1 1/2"	SG13TE				

DIN threaded

Nominal pipe size	Class									
	PN16		PN25		PN40		PN64		PN100	
	collet	tool	collet	tool	collet	tool	collet	tool	collet	tool
3/4"									M16 5/8"	SG4TM
1"									M16 5/8"	SG4TM
1 1/4"	M16 5/8"	SG4TM	M16 5/8"	SG4TM	M16 5/8"	SG4TM	M16 5/8"	SG4TM	M20 3/4"	SG4TM
1 1/2"	M16 5/8"	SG4TM	M16 5/8"	SG4TM	M16 5/8"	SG4TM	M16 5/8"	SG4TM	M20 3/4"	SG4TM
2"	M16 5/8"	SG4TM	M16 5/8"	SG4TM	M16 5/8"	SG4TM	M20 3/4"	SG4TM	M24 7/8"	SG6TM
2 1/2"	M16 5/8"	SG4TM	M16 5/8"	SG4TM	M16 5/8"	SG4TM	M20 3/4"	SG4TM	M24 7/8"	SG6TM
3"	M16 5/8"	SG4TM	M16 5/8"	SG4TM	M16 5/8"	SG4TM	M20 3/4"	SG4TM	M24 7/8"	SG6TM
4"	M16 5/8"	SG4TM	M20 3/4"	SG4TM	M20 3/4"	SG4TM	M24 7/8"	SG6TM	M27 1"	SG6TM
5"	M16 5/8"	SG4TM	M24 7/8"	SG6TM	M24 7/8"	SG6TM	M24 7/8"	SG6TM	M30 1 1/8"	SG11TM
6"	M16 5/8"	SG4TM	M24 7/8"	SG6TM	M24 7/8"	SG6TM	M30 1 1/8"	SG11TM	M30 1 1/8"	SG11TM



DIN weldneck

Nominal pipe size	Class											
	PN16		PN25		PN40		PN64		PN100		PN160	
	collet	tool	collet	tool	collet	tool	collet	tool	collet	tool	collet	tool
1"							M16 5/8"	SG4TM	M16 5/8"	SG4TM	M16 5/8"	SG4TM
1 1/4"	M16 5/8"	SG4TM	M16 5/8"	SG4TM	M16 5/8"	SG4TM						
1 1/2"	M16 5/8"	SG4TM	M16 5/8"	SG4TM	M16 5/8"	SG4TM	M20 3/4"	SG4TM	M20 3/4"	SG4TM	M20 3/4"	SG4TM
2"	M16 5/8"	SG4TM	M16 5/8"	SG4TM	M16 5/8"	SG4TM	M20 3/4"	SG4TM	M24 7/8"	SG6TM	M24 7/8"	SG6TM
2 1/2"	M16 5/8"	SG4TM	M16 5/8"	SG4TM	M16 5/8"	SG4TM	M20 3/4"	SG4TM	M24 7/8"	SG6TM	M24 7/8"	SG6TM
3"	M16 5/8"	SG4TM	M16 5/8"	SG4TM	M16 5/8"	SG4TM	M20 3/4"	SG4TM	M24 7/8"	SG6TM	M24 7/8"	SG6TM
4"	M16 5/8"	SG4TM	M16 5/8"	SG4TM	M16 5/8"	SG4TM	M24 7/8"	SG6TM	M27 1"	SG6TM	M27 1"	SG6TM
5"	M16 5/8"	SG4TM	M16 5/8"	SG4TM	M16 5/8"	SG4TM	M27 1"	SG6TM	M30 1 1/8"	SG11TM	M30 1 1/8"	SG11TM
6"	M20 3/4"	SG4TM	M20 3/4"	SG4TM	M20 3/4"	SG4TM	M30 1 1/8"	SG11TM	M30 1 1/8"	SG11TM	M30 1 1/8"	SG11TM
7"	M20 3/4"	SG4TM	M24 7/8"	SG6TM	M20 3/4"	SG4TM	M30 1 1/8"	SG11TM	M30 1 1/8"	SG11TM	M33 1 1/4"	SG11TM
8"	M20 3/4"	SG4TM	M24 7/8"	SG6TM	M20 3/4"	SG4TM	M33 1 1/4"	SG11TM	M33 1 1/4"	SG11TM	M33 1 1/4"	SG11TM
10"	M24 7/8"	SG6TM	M27 1"	SG6TM	M24 7/8"	SG6TM	M33 1 1/4"	SG11TM	M36 1 3/8"	SG11TM	M39 1 1/2"	SG13TE
12"	M24 7/8"	SG6TM	M27 1"	SG6TM	M24 7/8"	SG6TM	M33 1 1/4"	SG11TM	M39 1 1/2"	SG13TE	M39 1 1/2"	SG13TE
14"	M24 7/8"	SG6TM	M30 1 1/8"	SG11TM	M24 7/8"	SG6TM	M36 1 3/8"	SG11TM	M45 1 3/4"	SG13TE		
16"	M27 1"	SG6TM	M33 1 1/4"	SG11TM	M27 1"	SG6TM	M39 1 1/2"	SG13TE				
18"	M27 1"	SG6TM	M33 1 1/4"	SG11TM	M27 1"	SG6TM						
20"	M30 1 1/8"	SG11TM	M33 1 1/4"	SG11TM	M30 1 1/8"	SG11TM						
24"	M33 1 1/4"	SG11TM	M36 1 3/8"	SG11TM								
28"	M33 1 1/4"	SG11TM	M39 1 1/2"	SG13TE								
32"	M36 1 3/8"	SG11TM	M45 1 3/4"	SG13TE								
36"	M36 1 3/8"	SG11TM	M45 1 3/4"	SG13TE								
40"	M39 1 1/2"	SG13TE	M52 2"	SG15TE								
48"	M45 1 3/4"	SG13TE										
56"	M45 1 3/4"	SG13TE										
64"	M52 2"	SG15TE										
72"	M52 2"	SG15TE										
80"	M56 2 1/4"	SG15TE										

DIN flat

Nominal pipe size	Class			
	PN6		PN10	
	collet	tool	collet	tool
1 1/4"			M16 5/8"	SG4TM
1 1/2"			M16 5/8"	SG4TM
2"			M16 5/8"	SG4TM
2 1/2"			M16 5/8"	SG4TM
3"	M16 5/8"	SG4TM	M16 5/8"	SG4TM
4"	M16 5/8"	SG4TM	M16 5/8"	SG4TM
5"	M16 5/8"	SG4TM	M16 5/8"	SG4TM
6"	M16 5/8"	SG4TM	M20 3/4"	SG4TM
8"	M16 5/8"	SG4TM	M20 3/4"	SG4TM
10"	M16 5/8"	SG4TM	M20 3/4"	SG4TM
12"	M20 3/4"	SG4TM	M20 3/4"	SG4TM
14"	M20 3/4"	SG4TM	M20 3/4"	SG4TM
16"	M20 3/4"	SG4TM	M24 7/8"	SG6TM
18"	M20 3/4"	SG4TM	M24 7/8"	SG6TM
20"	M20 3/4"	SG4TM	M24 7/8"	SG6TM

DIN lapped

Nominal pipe size	Class			
	PN6		PN10	
	collet	tool	collet	tool
1 1/4"			M16 5/8"	SG4TM
1 1/2"			M16 5/8"	SG4TM
2"			M16 5/8"	SG4TM
2 1/2"			M16 5/8"	SG4TM
3"	M16 5/8"	SG4TM	M16 5/8"	SG4TM
4"	M16 5/8"	SG4TM	M16 5/8"	SG4TM
5"	M16 5/8"	SG4TM	M16 5/8"	SG4TM
6"	M16 5/8"	SG4TM	M20 3/4"	SG4TM
8"	M16 5/8"	SG4TM	M20 3/4"	SG4TM
10"	M16 5/8"	SG4TM	M20 3/4"	SG4TM
12"	M20 3/4"	SG4TM	M20 3/4"	SG4TM
14"	M20 3/4"	SG4TM	M20 3/4"	SG4TM
16"	M20 3/4"	SG4TM	M24 7/8"	SG6TM
18"	M20 3/4"	SG4TM	M24 7/8"	SG6TM
20"	M20 3/4"	SG4TM	M24 7/8"	SG6TM
24"	M24 7/8"	SG6TM	M27 1"	SG6TM
28"	M24 7/8"	SG6TM	M27 1"	SG6TM
32"	M27 1"	SG6TM	M30 1 1/8"	SG11TM
36"	M27 1"	SG6TM		
40"	M27 1"	SG6TM		



ASME series A weld neck

Nominal pipe size	Class														
	150		300		400		600		900		1500		2500		
	collet	tool	collet	tool	collet	tool	collet	tool	collet	tool	collet	tool	collet	tool	
1/2"										M20 3/4"	SG4TM	M20 3/4"	SG4TM	M20 3/4"	SG4TM
3/4"			M16 5/8"	SG4TM	M16 5/8"	SG4TM	M16 5/8"	SG4TM	M20 3/4"	SG4TM	M20 3/4"	SG4TM	M20 3/4"	SG4TM	
1"			M16 5/8"	SG4TM	M16 5/8"	SG4TM	M16 5/8"	SG4TM	M24 7/8"	SG6TM	M24 7/8"	SG6TM	M24 7/8"	SG6TM	
1 1/4"			M16 5/8"	SG4TM	M16 5/8"	SG4TM	M16 5/8"	SG4TM	M24 7/8"	SG6TM	M24 7/8"	SG6TM	M27 1"	SG6TM	
1 1/2"			M20 3/4"	SG4TM	M20 3/4"	SG4TM	M20 3/4"	SG4TM	M27 1"	SG6TM	M27 1"	SG6TM	M30 1 1/8"	SG11TM	
2"	M16 5/8"	SG4TM	M16 5/8"	SG4TM	M16 5/8"	SG4TM	M16 5/8"	SG4TM	M24 7/8"	SG6TM	M24 7/8"	SG6TM	M27 1"	SG6TM	
2 1/2"	M16 5/8"	SG4TM	M20 3/4"	SG4TM	M20 3/4"	SG4TM	M20 3/4"	SG4TM	M27 1"	SG6TM	M27 1"	SG6TM	M30 1 1/8"	SG11TM	
3"	M16 5/8"	SG4TM	M20 3/4"	SG4TM	M20 3/4"	SG4TM	M20 3/4"	SG4TM	M24 7/8"	SG6TM	M30 1 1/8"	SG11TM	M33 1 1/4"	SG11TM	
3 1/2"	M16 5/8"	SG4TM	M20 3/4"	SG4TM	M24 7/8"	SG6TM	M24 7/8"	SG6TM							
4"	M16 5/8"	SG4TM	M20 3/4"	SG4TM	M24 7/8"	SG6TM	M24 7/8"	SG6TM	M30 1 1/8"	SG11TM	M33 1 1/4"	SG11TM	M39 1 1/2"	SG13TE	
5"	M20 3/4"	SG4TM	M20 3/4"	SG4TM	M24 7/8"	SG6TM	M27 1"	SG6TM	M33 1 1/4"	SG11TM	M39 1 1/2"	SG13TE	M45 1 3/4"	SG13TE	
6"	M20 3/4"	SG4TM	M20 3/4"	SG4TM	M24 7/8"	SG6TM	M27 1"	SG6TM	M30 1 1/8"	SG11TM	M36 1 3/8"	SG11TM	M52 2"	SG15TE	
8"	M20 3/4"	SG4TM	M24 7/8"	SG6TM	M27 1"	SG6TM	M30 1 1/8"	SG11TM	M36 1 3/8"	SG11TM	M42 1 5/8"	SG13TE	M52 2"	SG15TE	
10"	M24 7/8"	SG6TM	M27 1"	SG6TM	M30 1 1/8"	SG11TM	M33 1 1/4"	SG11TM	M36 1 3/8"	SG11TM	M48 1 7/8"	SG15TE	M64 2 1/2"	SG18TE	
12"	M24 7/8"	SG6TM	M30 1 1/8"	SG11TM	M33 1 1/4"	SG11TM	M33 1 1/4"	SG11TM	M36 1 3/8"	SG11TM	M52 2"	SG15TE	M70 2 3/4"	SG18TE	
14"	M27 1"	SG6TM	M30 1 1/8"	SG11TM	M33 1 1/4"	SG11TM	M36 1 3/8"	SG11TM	M39 1 1/2"	SG13TE	M56 2 1/4"	SG15TE			
16"	M27 1"	SG6TM	M33 1 1/4"	SG11TM	M36 1 3/8"	SG11TM	M39 1 1/2"	SG13TE	M42 1 5/8"	SG13TE	M64 2 1/2"	SG18TE			
18"	M30 1 1/8"	SG11TM	M33 1 1/4"	SG11TM	M36 1 3/8"	SG11TM	M42 1 5/8"	SG13TE	M48 1 7/8"	SG15TE	M70 2 3/4"	SG18TE			
20"	M30 1 1/8"	SG11TM	M33 1 1/4"	SG11TM	M39 1 1/2"	SG13TE	M42 1 5/8"	SG13TE	M52 2"	SG15TE	M76 3"	SG25TE			
22"															
24"	M33 1 1/4"	SG11TM	M39 1 1/2"	SG13TE	M45 1 3/4"	SG13TE	M48 1 7/8"	SG15TE	M64 2 1/2"	SG18TE	M90 3 1/2"	SG25TE			
26"	M33 1 1/4"	SG11TM	M42 1 5/8"	SG13TE	M42 1 5/8"	SG13TE	M48 1 7/8"	SG15TE	M70 2 3/4"	SG18TE					
28"	M33 1 1/4"	SG11TM	M42 1 5/8"	SG13TE	M42 1 5/8"	SG13TE	M52 2"	SG15TE	M76 3"	SG25TE					
30"	M33 1 1/4"	SG11TM	M45 1 3/4"	SG13TE	M45 1 3/4"	SG13TE	M56 2 1/4"	SG15TE	M76 3"	SG25TE					
32"	M39 1 1/2"	SG13TE	M48 1 7/8"	SG15TE	M48 1 7/8"	SG15TE	M56 2 1/4"	SG15TE	M84	SG25TE					
34"	M39 1 1/2"	SG13TE	M48 1 7/8"	SG15TE	M48 1 7/8"	SG15TE	M56 2 1/4"	SG15TE	M90 3 1/2"	SG25TE					
36"	M39 1 1/2"	SG13TE	M52 2"	SG15TE	M52 2"	SG15TE	M56 2 1/4"	SG15TE	M90 3 1/2"	SG25TE					
38"	M39 1 1/2"	SG13TE	M39 1 1/2"	SG13TE	M39 1 1/2"	SG13TE	M56 2 1/4"	SG15TE	M90 3 1/2"	SG25TE					
40"	M39 1 1/2"	SG13TE	M42 1 5/8"	SG13TE	M42 1 5/8"	SG13TE	M56 2 1/4"	SG15TE	M90 3 1/2"	SG25TE					
42"	M39 1 1/2"	SG13TE	M42 1 5/8"	SG13TE	M42 1 5/8"	SG13TE	M56 2 1/4"	SG15TE	M90 3 1/2"	SG25TE					
44"	M39 1 1/2"	SG13TE	M45 1 3/4"	SG13TE	M45 1 3/4"	SG13TE	M56 2 1/4"	SG15TE	M95 3 3/4"	SG25TE					
46"	M39 1 1/2"	SG13TE	M48 1 7/8"	SG15TE	M48 1 7/8"	SG15TE	M56 2 1/4"	SG15TE	M100 4"	SG25TE					
48"	M39 1 1/2"	SG13TE	M48 1 7/8"	SG15TE	M48 1 7/8"	SG15TE	M70 2 3/4"	SG18TE	M100 4"	SG25TE					



ASME series A lapped

Nominal pipe size	Class														
	150		300		400		600		900		1500		2500		
	collet	tool	collet	tool	collet	tool	collet	tool	collet	tool	collet	tool	collet	tool	
1/2"										M20 3/4"	SG4TM	M20 3/4"	SG4TM	M20 3/4"	SG4TM
3/4"			M16 5/8"	SG4TM	M16 5/8"	SG4TM	M16 5/8"	SG4TM	M20 3/4"	SG4TM	M20 3/4"	SG4TM	M20 3/4"	SG4TM	
1"			M16 5/8"	SG4TM	M16 5/8"	SG4TM	M16 5/8"	SG4TM	M24 7/8"	SG6TM	M24 7/8"	SG6TM	M24 7/8"	SG6TM	
1 1/4"			M16 5/8"	SG4TM	M16 5/8"	SG4TM	M16 5/8"	SG4TM	M24 7/8"	SG6TM	M24 7/8"	SG6TM	M27 1"	SG6TM	
1 1/2"			M20 3/4"	SG4TM	M20 3/4"	SG4TM	M20 3/4"	SG4TM	M27 1"	SG6TM	M27 1"	SG6TM	M30 1 1/8"	SG11TM	
2"	M16 5/8"	SG4TM	M16 5/8"	SG4TM	M16 5/8"	SG4TM	M16 5/8"	SG4TM	M24 7/8"	SG6TM	M24 7/8"	SG6TM	M27 1"	SG6TM	
2 1/2"	M16 5/8"	SG4TM	M20 3/4"	SG4TM	M20 3/4"	SG4TM	M20 3/4"	SG4TM	M27 1"	SG6TM	M27 1"	SG6TM	M30 1 1/8"	SG11TM	
3"	M16 5/8"	SG4TM	M20 3/4"	SG4TM	M20 3/4"	SG4TM	M20 3/4"	SG4TM	M24 7/8"	SG6TM	M30 1 1/8"	SG11TM	M33 1 1/4"	SG11TM	
3 1/2"	M16 5/8"	SG4TM	M20 3/4"	SG4TM	M24 7/8"	SG6TM	M24 7/8"	SG6TM	no flange		no flange		no flange		
4"	M16 5/8"	SG4TM	M20 3/4"	SG4TM	M24 7/8"	SG6TM	M24 7/8"	SG6TM	M30 1 1/8"	SG11TM	M33 1 1/4"	SG11TM	M39 1 1/2"	SG13TE	
5"	M20 3/4"	SG4TM	M20 3/4"	SG4TM	M24 7/8"	SG6TM	M27 1"	SG6TM	M33 1 1/4"	SG11TM	M39 1 1/2"	SG13TE	M45 1 3/4"	SG13TE	
6"	M20 3/4"	SG4TM	M20 3/4"	SG4TM	M24 7/8"	SG6TM	M27 1"	SG6TM	M30 1 1/8"	SG11TM	M36 1 3/8"	SG11TM	M52 2"	SG15TE	
8"	M20 3/4"	SG4TM	M24 7/8"	SG6TM	M27 1"	SG6TM	M30 1 1/8"	SG11TM	M36 1 3/8"	SG11TM	M42 1 5/8"	SG13TE	M52 2"	SG15TE	
10"	M24 7/8"	SG6TM	M27 1"	SG6TM	M30 1 1/8"	SG11TM	M33 1 1/4"	SG11TM	M36 1 3/8"	SG11TM	M48 1 7/8"	SG15TE	M64 2 1/2"	SG18TE	
12"	M24 7/8"	SG6TM	M30 1 1/8"	SG11TM	M33 1 1/4"	SG11TM	M33 1 1/4"	SG11TM	M36 1 3/8"	SG11TM	M52 2"	SG15TE	M70 2 3/4"	SG18TE	

ASME series A socket welded

Nominal pipe size	Class							
	150		300		600		1500	
	collet	tool	collet	tool	collet	tool	collet	tool
1/2"							M20 3/4"	SG4TM
3/4"			M16 5/8"	SG4TM	M16 5/8"	SG4TM	M20 3/4"	SG4TM
1"			M16 5/8"	SG4TM	M16 5/8"	SG4TM	M24 7/8"	SG6TM
1 1/4"			M16 5/8"	SG4TM	M16 5/8"	SG4TM	M24 7/8"	SG6TM
1 1/2"			M20 3/4"	SG4TM	M20 3/4"	SG4TM	M27 1"	SG6TM
2"	M16 5/8"	SG4TM	M16 5/8"	SG4TM	M16 5/8"	SG4TM	M24 7/8"	SG6TM
2 1/2"	M16 5/8"	SG4TM	M20 3/4"	SG4TM	M20 3/4"	SG4TM	M27 1"	SG6TM
3"	M16 5/8"	SG4TM	M20 3/4"	SG4TM	M20 3/4"	SG4TM		

ASME series B weld neck and blind

Nominal pipe size	Class									
	150		300		400		600		900	
	collet	tool	collet	tool	collet	tool	collet	tool	collet	tool
26"	M20 3/4"	SG4TM	M33 1 1/4"	SG11TM	M36 1 3/8"	SG11TM	M42 1 5/8"	SG13TE	M64 2 1/2"	SG18TE
28"	M20 3/4"	SG4TM	M33 1 1/4"	SG11TM	M39 1 1/2"	SG13TE	M45 1 3/4"	SG13TE	M70 2 3/4"	SG18TE
30"	M20 3/4"	SG4TM	M36 1 3/8"	SG11TM	M39 1 1/2"	SG13TE	M48 1 7/8"	SG15TE	M76 3"	SG25TE
32"	M20 3/4"	SG4TM	M39 1 1/2"	SG13TE	M42 1 5/8"	SG13TE	M52 2"	SG15TE	M76 3"	SG25TE
34"	M24 7/8"	SG6TM	M39 1 1/2"	SG13TE	M42 1 5/8"	SG13TE	M56 2 1/4"	SG15TE	M80 3 1/4"	SG25TE
36"	M24 7/8"	SG6TM	M42 1 5/8"	SG13TE	M45 1 3/4"	SG13TE	M56 2 1/4"	SG15TE	M76 3"	SG25TE
42"	M27 1"	SG6TM	M45 1 3/4"	SG13TE						
48"	M30 1 1/8"	SG11TM	M48 1 7/8"	SG15TE						
54"	M30 1 1/8"	SG11TM	M48 1 7/8"	SG15TE						
60"	M33 1 1/4"	SG11TM	M56 2 1/4"	SG15TE						



API 6B weld neck

Nominal pipe size	Class					
	138 bar (2000 psi)		207 bar (3000 psi)		345 bar (5000 psi)	
	collet	tool	collet	tool	collet	tool
2 1/16"	M16 5/8"	SG4TM	M24 7/8"	SG6TM	M24 7/8"	SG6TM
2 9/16"	M20 3/4"	SG4TM	M27 1"	SG6TM	M27 1"	SG6TM
3 1/8"	M20 3/4"	SG4TM	M24 7/8"	SG6TM	M30 1 1/8"	SG11TM
4 1/16"	M24 7/8"	SG6TM	M30 1 1/8"	SG11TM	M33 1 1/4"	SG11TM
5 1/8"	M27 1"	SG6TM	M33 1 1/4"	SG11TM	M39 1 1/2"	SG13TE
7 1/16"	M27 1"	SG6TM	M30 1 1/8"	SG11TM	M36 1 3/8"	SG11TM
9"	M30 1 1/8"	SG11TM	M36 1 3/8"	SG11TM	M42 1 5/8"	SG13TE
11"	M33 1 1/4"	SG11TM	M36 1 3/8"	SG11TM	M48 1 7/8"	SG15TE

API 6B blind and threaded

Nominal pipe size	Class					
	138 bar (2000 psi)		207 bar (3000 psi)		345 bar (5000 psi)	
	collet	tool	collet	tool	collet	tool
2 1/16"	M16 5/8"	SG4TM	M24 7/8"	SG6TM	M24 7/8"	SG6TM
2 9/16"	M20 3/4"	SG4TM	M27 1"	SG6TM	M27 1"	SG6TM
3 1/8"	M20 3/4"	SG4TM	M24 7/8"	SG6TM	M30 1 1/8"	SG11TM
4 1/16"	M24 7/8"	SG6TM	M30 1 1/8"	SG11TM	M33 1 1/4"	SG11TM
5 1/8"	M27 1"	SG6TM	M33 1 1/4"	SG11TM	M39 1 1/2"	SG13TE
7 1/16"	M27 1"	SG6TM	M30 1 1/8"	SG11TM	M36 1 3/8"	SG11TM
9"	M30 1 1/8"	SG11TM	M36 1 3/8"	SG11TM	M42 1 5/8"	SG13TE
11"	M33 1 1/4"	SG11TM	M36 1 3/8"	SG11TM	M48 1 7/8"	SG15TE
13 5/8"	M33 1 1/4"	SG11TM	M36 1 3/8"	SG11TM		
16 3/4"	M39 1 1/2"	SG13TE	M42 1 5/8"	SG13TE		
21 1/4"	M42 1 5/8"	SG13TE	M52 2"	SG15TE		

API 6BX weld neck

Nominal pipe size	Class					
	690 bar (10000 psi)		1035 bar (15000 psi)		1380 bar (20000 psi)	
	collet	tool	collet	tool	collet	tool
1 13/16"	M20 3/4"	SG4TM	M24 7/8"	SG6TM	M27 1"	SG6TM
2 1/16"	M20 3/4"	SG4TM	M24 7/8"	SG6TM	M30 1 1/8"	SG11TM
2 9/16"	M24 7/8"	SG6TM	M27 1"	SG6TM	M33 1 1/4"	SG11TM
3 1/16"	M27 1"	SG6TM	M30 1 1/8"	SG11TM	M36 1 3/8"	SG11TM
4 1/16"	M30 1 1/8"	SG11TM	M36 1 3/8"	SG11TM	M45 1 3/4"	SG13TE
5 1/8"	M30 1 1/8"	SG11TM				
7 1/16"	M39 1 1/2"	SG13TE	M39 1 1/2"	SG13TE	M52 2"	SG15TE
9"	M39 1 1/2"	SG13TE				
11"	M45 1 3/4"	SG13TE				
13 5/8"	M48 1 7/8"	SG15TE				
16 3/4"	M48 1 7/8"	SG15TE				

API 6BX blind and test

Nominal pipe size	Class					
	690 bar (10000 psi)		1035 bar (15000 psi)		1380 bar (20000 psi)	
	collet	tool	collet	tool	collet	tool
1 13/16"	M20 3/4"	SG4TM	M24 7/8"	SG6TM	M27 1"	SG6TM
2 1/16"	M20 3/4"	SG4TM	M24 7/8"	SG6TM	M30 1 1/8"	SG11TM
2 9/16"	M24 7/8"	SG6TM	M27 1"	SG6TM	M33 1 1/4"	SG11TM
3 1/16"	M27 1"	SG6TM	M33 1 1/4"	SG11TM	M36 1 3/8"	SG11TM
4 1/16"	M30 1 1/8"	SG11TM	M42 1 5/8"	SG13TE	M45 1 3/4"	SG13TE



BS APPLICATION CHART

Nominal pipe size	A		D		E		F		H		J		K		R		S		T		
	collet	tool	collet	tool	collet	tool	collet	tool	collet	tool	collet	tool	collet	tool	collet	tool	collet	tool	collet	tool	
1/2"																					
3/4"																					
1"								M16 5/8"													
1 1/4"								M16 5/8"													
1 1/2"								M16 5/8"													
2"								M16 5/8"													
2 1/2"								M16 5/8"													
3"								M16 5/8"													
3 1/2"								M16 5/8"													
4"								M16 5/8"													
4 1/2"								M16 5/8"													
5"								M20 3/4"													
6"								M20 3/4"													
7"								M20 3/4"													
8"								M20 3/4"													
9"								M20 3/4"													
10"								M20 3/4"													
11"								M24 7/8"													
12"								M24 7/8"													
13"								M24 7/8"													
14"								M24 7/8"													
15"								M24 7/8"													
16"								M24 7/8"													
17"								M24 7/8"													
18"								M24 7/8"													
19"								M24 7/8"													
20"								M24 7/8"													
21"								M24 7/8"													
22"								M27 1"													
23"								M27 1"													
24"								M27 1"													
26"								no flange													
27"								M30 1 1/8"													
29"								M30 1 1/8"													
30"								M33 1 1/4"													
33"								M33 1 1/4"													
35"								M39 1 1/2"													
36"								M39 1 1/2"													
39"								M39 1 1/2"													
42"								M33 1 1/4"													
45"								M36 1 3/8"													
48"								M36 1 3/8"													
54"								M42 2 1/2"													
60"								M42 2 1/2"													
66"								M39 1 1/2"													
72"								M39 1 1/2"													
78"								M39 1 1/2"													
84"								M45 1 3/4"													
96"								M45 1 3/4"													
108"								M45 1 3/4"													
120"								M52 2"													