

OPERATING INSTRUCTIONS

NutBee®

- Original operating instructions -



NOTE

In case of doubt, the original German version of the operating instructions applies.

**Cordless blind riveting tool
NBPS-21 / NBPf-25**

Issue date:

July 2021

Tool Firmware:

from 2.2.6.0

HST-Tool-Manager:

from 2.0.6.0

Table of contents

PAGE	4	1 Operating principles	
		1.1	Scope of delivery 4
		1.2	General information 4
		1.3	Signs and symbols used 6
		1.4	Structure of the warnings 7
		1.5	Technical terms and abbreviations used 7
		1.6	Intended use 8
		1.7	Improper use 8
		1.8	Duties of the operator 9
		1.9	Duties of personnel 9
		1.10	Training of personnel 10
		1.11	Guarantee and liability 10
		1.12	Copyright 11
PAGE	12	2 General safety information for power tools	
		2.1	Occupational safety 12
		2.2	Electrical safety 13
		2.3	Safety of people 13
		2.4	Use and handling of power tools 14
		2.5	Use and handling of battery tools 15
		2.6	Service 16
PAGE	17	3 Important information about this tool	
		3.1	Handling the associated lithium ion battery 17
		3.2	Information on the associated charger 18
		3.3	Structural modifications 18
		3.4	Cleaning the device and disposal 19
PAGE	20	4 Start-up and use	
		4.1	Tool structure 21
		4.2	Operation 22
		4.2.1	Inserting and removing the battery 22
		4.2.2	Press start button 23
		4.2.3	Front LED 23
		4.2.4	LED indicator at the back and sound signals 24
		4.2.5	OLED Display 24
		4.2.6	Selection of threaded mandrel and nose piece 25
		4.2.7	Adjusting the nose piece 26
		4.2.8	Set blind rivet nuts 26
		4.2.9	Spinning off 27
		4.2.10	Tool tilted or blocked 28
		4.2.11	Overload 29
		4.2.12	Standby and Shut-down mode 29
		4.2.13	Charge state of the battery 30
		4.3	Display 31

4.3.1	Display notifications	32
4.4	HST-Tool-Manager	37
4.4.1	Setup	40
4.4.2	General → Process control	40
4.4.3	General → energy & lighting	42
4.4.4	General → features	43
4.4.5	General → TM version	44
4.4.6	Management	45
4.4.7	Signals → OLED-display	46
4.4.8	Signals → LED	47
4.4.9	Signals → sound signals	48
4.4.10	Signals → vibration alarm	49
4.4.11	Graphics	50
4.4.12	System time	51
4.4.13	Basic settings	52
4.4.14	Update	53
4.4.15	Programming	54
4.4.16	Program	54
4.4.17	Program → Option	62
4.5	Maintenance and servicing	64
4.6	Cleaning	64
4.6.1	General information	64
4.6.2	Cleaning / replacement of the threaded mandrel	65
4.6.3	Machine capability test (MCT)	65
4.6.4	Service interval counter	66

PAGE **67** **5 Storage**

PAGE **68** **6 Technical data**

PAGE **70** **7 Troubleshooting and Fault repair**

PAGE **71** **CE Declaration of conformity**

1 Operating principles

Dear customers,

thank you for choosing a HS-Technik GmbH product.

This quality product „Made in Germany“ fulfils the highest requirements with regard to performance, quality and accuracy. When used correctly the product will undoubtedly perform very well for many years.

These operating instructions contain information on safety and for the operation of the tool. In addition it contains information on the dimensions and technical data. We would be happy to assist you with additional information or to answer your questions. Our technical support and our technicians would be happy to assist you.

1.1 Scope of delivery

- Cordless blind riveting tool
- USB Cable (Type A on Mini B)
- Operating instructions

1.2 General information

Read the tool operating instructions before initial operation. **Please pay particular attention to Chapter 2 „General Safety Notes“.**

This operating instruction should make it easier for the operator to get to know the tool and to use it for its intended purpose. The operating instructions include important information related to the safe and proper operation of the tool. Compliance with these instructions helps you to:

- Avoid hazards
- Avoid repair costs and downtimes
- Increase the reliability and the lifespan of the product.

This operating instructions must be read and applied by every person who is assigned to conduct work using this tool.

In addition to this operating instructions the applicable regulations on accident prevention and environmental protection should be observed.

















NOTE

After reading, keep the operating instructions in a place accessible to every operator. If you have any further questions, please feel free to contact us.

1.3 Signs and symbols used

The following signs and symbols will be used in this operating instructions or on the product:

Symbol	Explanation
	Read this operating instructions
	Do not dispose with household waste
	Do not dispose the battery in a fire
	Do not throw the battery into water
	EU conformity marking
	Registered trademark
	Use only indoors
	Protection class II
	Intrinsically safe transformer
	Battery is charging
	Defective battery
	Battery fully charged
	Direct current
	Universal Recycling Symbol

1.4 Structure of the warnings

The warnings are structured as follows:



DANGER

Indicates an immediate dangerous situation that can lead to serious or even deadly injuries and/or that could seriously damage or even destroy the tool.



WARNING

Indicates a potentially dangerous situation that can lead to serious injuries and/or damage to the tool.



NOTE

Important and useful information on using this tool.

1.5 Technical terms and abbreviations used

Abbreviation	Meaning
°C	Degrees Celsius, temperature
A/C	Alternate current
Ah	Amp hours, electric charge, battery capacity
a_{hv}	Overall vibration
dB(A)	Decibels, sound pressure level (A-weighted)
D/C	Direct current
Hz	Hertz, Frequency
Li-Ion	Lithium-ion, battery technology
L_{pA}	Emission sound pressure level, workplace-related
m/s^2	Acceleration, Vibration

Abbreviation	Meaning
min ⁻¹	Revolutions per minute, Speed
mNN	Meters above sea level, height
SN	Serial number
V	Volts, electrical voltage
W	Watts, electrical power

1.6 Intended use

This battery operated blind riveting tool was designed to prepare rivet joints. The tool may only be used for this purpose as described in this operating instructions. Only materials that are suitable for this type of tool may be used.



WARNING

Intended use also includes

- following all indications of the operating instructions and
- observance of inspection and maintenance works.

Any other use or use beyond that is considered improper use. HS-Technik GmbH is not liable for any damage resulting from this.

1.7 Improper use



DANGER

The use of this tool for other purposes, e.g. for hammering, is not permitted. Improper use or incorrect accessories can lead to dangers with unforeseeable consequences.

We accept no liability for damage and malfunctions resulting from non-observance of these operating instructions and improper use.

1.8 Duties of the operator

The operator undertakes to only allow people who are familiar with the basic regulations on occupational safety and accident prevention and who have been trained on how to use the tool at the workplace to work with this tool.

The safety awareness of the personnel while working has to be reviewed at regular intervals.

In addition it is necessary to establish safety measures for operator safety which are based upon an estimation of the vibration load during actual conditions of use.

1.9 Duties of personnel

Prior to its use all people who work with this tool are obligated to inform themselves of the applicable workplace safety and accident prevention regulations for this power tool and to observe them.

It is recommended that every operator wears hearing protection.

1.10 Training of personnel

Only trained and instructed personnel should work with this tool. The responsibilities of the personnel must be clearly defined. Trainees may only work with this power tool under the supervision of an experienced person.

1.11 Guarantee and liability

Guarantee and liability claims for personal injury and property damage are excluded, if caused by one or more of the following:

- improper use
- failure to observe these operating instructions
- improper installation, commissioning, operation and maintenance of the device
- Operating the device with defective safety devices or improperly installed or non-functioning safety and protective devices
- Failure to observe the information in the operating instructions regarding transport, storage, assembly, commissioning, operation and maintenance of the device
- unauthorised structural modifications to the device
- improperly performed repairs
- catastrophes due to external influences and acts of God

1.12 Copyright

These operating instructions are intended solely for the operator and its personnel.

They contain guidelines and information which may not be fully or partially

- reproduced
- distributed or
- otherwise shared.

The copyright of these operating instructions is retained by HS-Technik GmbH.

Manufacturer's address:

HS-Technik GmbH
High - System - Technik

Im Martelacker 12
D-79588 Efringen-Kirchen

Telephone: +49 (0)7628 - 91 11-0
Fax: +49 (0)7628 - 91 11-90
E-mail: info@hs-technik.com
Internet: www.hs-technik.com

2 General safety information for power tools



DANGER

Read all the safety information, instructions, illustrations and technical data which is provided with this power tool. Failure to follow the instructions below may result in electric shock, fire and/or serious injury.



WARNING

This power tool was manufactured in accordance with current state-of-the-art technology and recognised technological safety guidelines. However, its use may jeopardise the health and life of the user or third parties or risk damage to other property.



WARNING

The workplace must only be used in accordance with its intended use and in absolutely perfect condition.



NOTE

Keep all safety information and instructions for the future.



NOTE

Only have your device repaired by qualified professional staff and only with original replacement parts which are available at HS Technik GmbH. This ensures that the safety of the device is maintained.

The term „power tool“ used in the safety information refers to mains-operated power tools (with mains cable) and to battery-operated power tools (without mains cable).

2.1 Occupational safety

- a) **Keep your work area clean and well-lit.** Cluttered or dark work areas can lead to accidents.
- b) **Do not work with the power tool in an explosive environment in which there are flammable liquids, gases or dust.** Power tools generate sparks that can ignite the dust or fumes.

- c) **Keep children and other people away while using the power tool.** You can lose control of the power tool if you are distracted.

2.2 Electrical safety

- a) **Avoid body contact with grounded surfaces such as pipes, heaters, stoves and refrigerators.** There is an increased risk of electric shock if your body is grounded.
- b) **Keep power tools away from rain or moisture.** Penetration of water into a power tool increases the risk of electric shock.
- c) **Do not misuse the connection cable in order to carry or hang up the charger or to pull the plug out of the socket. Keep the connection cable away from heat, oil, sharp edges or moving parts.** Damaged or tangled connection cables increase the risk of electric shock.
- d) **If operating the charger in a damp environment cannot be avoided, use a fault-current circuit breaker.** The use of a fault-current circuit breaker reduces the risk of electric shock.
- e) **Check the electrical equipment regularly. Immediately remove loose connections and scorched cables.** Loose connections or scorched cables can lead to electric shock and risk of fire.

2.3 Safety of people

- a) **Be alert, pay attention to what you are doing and take care when you are working with a power tool. Do not use a power tool when you are tired or under the influence of drugs, alcohol or medication.** A moment of inattention while using the power tool can result in serious injury.
- b) **Wear personal protective equipment and always safety glasses.** Wearing personal protective equipment such as a dust mask, non-slip safety shoes, safety helmet or hearing protection, depending on the type and use of the power tool lowers the risk of injury.
- c) **Prevent accidental starting. Ensure that the power tool is switched off before you connect it to the power supply and/or the battery, pick it up or carry it.** Accidents can occur if you have your finger on the switch while carrying the power tool or if you connect the power tool to the power supply when it is switched on.

- d) **Avoid abnormal postures. Make sure you have a secure footing and keep your balance at all times.** This gives you better control of the power tool in unexpected situations.
- e) **Wear suitable clothing. Do not wear loose clothing or jewellery. Keep hair and clothing away from moving parts.** Loose clothing, jewellery or long hair can get caught in moving parts.
- f) **Do not lull yourself into a false sense of security and do not disregard the safety rules for power tools, even if you are familiar with the power tool after repeated use.** Careless action can lead to serious injuries within a split second.
- g) **Actively avoid accidentally switching on the power tool. If the tool is to be in idle mode for a long time, remove the battery beforehand.** This prevents unintentional start-up.

2.4 Use and handling of power tools

- a) **Do not overload the power tool. Use the power tool specific for the work you are doing.** With the appropriate power tool you will work better and more safely in the power range indicated.
- b) **Do not use any power tool which has a defective switch.** A power tool which can no longer be switched on or off is dangerous and must be repaired.
- c) **Remove the detachable battery before you make changes to device settings, change application tool parts or put away the power tool.** This precaution prevents unintentional start up of the power tool.
- d) **Keep unused power tools out of the reach of children. Do not let anyone use the power tool who is not familiar with it or has not read this operating instructions.** Power tools are dangerous when used by inexperienced people.
- e) **Maintain power tools and the application tool with care. Check whether moving parts function properly and do not jam, whether parts are broken or damaged in such a way that the function of the power tool is affected. Have damaged parts repaired before using the power tool.** Many accidents are caused by poorly serviced power tools.
- f) **Keep the tool sharp and clean.** Carefully maintained tools jam less often and are easier to manage.

- g) **Use power tools, application tools, etc. in accordance with these instructions. While doing so observe the work conditions and the activities to be performed.** The use of power tools for anything other than the intended application can lead to dangerous situations.
- h) **Keep handles and gripping surfaces dry, clean and free of oil and grease.** Slippery handles and gripping surfaces do not allow safe operation and control of the power tool in unforeseen situations.
- i) **Use the correct power tool.** Do not use under-performing tools for heavy loads. Do not use tools for purposes and work for which they are not intended.
- j) **Check your device for damage.** Before continued use of the tool safety equipment must be tested for proper and intended function. Check whether the function of moving parts is okay, whether they do not jam, whether any parts are broken, whether all other parts function properly and whether all conditions which must be met for the proper operation of the device have been met. Damaged protective devices and parts should be properly repaired or replaced by trained customer service unless otherwise specified in this operating instructions. Damaged switches must be replaced by a customer service workshop. Do not use any tools which cannot be properly switched on and off using the start button.

2.5 Use and handling of battery tools

- a) **Charge the battery only with charging devices which are recommended by the manufacturer.** There is a risk of fire if the battery is used on an unsuitable charger and the battery can be permanently damaged.
- b) **Use only the specifically designated battery for the power tool.** The use of other batteries can lead to injuries and the risk of fire.
- c) **Keep the unused battery away from paper clips, coins, keys, nails, bolts or other small metal parts which could cause a bypass of the contacts. Do not open the battery and do not short circuit.** A short circuit between the battery contacts can lead to burns or fire.
- d) **Fluid can leak out of the battery in the event of incorrect use. Avoid contact with it. In the event of accidental contact with skin rinse with water. If the fluid comes into contact with the eye seek medical help.** Leaking battery fluid can lead to skin irritations or burns.

- e) **Do not use damaged or altered batteries.** Damaged or altered batteries can behave unpredictably and can lead to fire, explosion or injury.
- f) **Do not expose a battery to fire or high temperatures.** Fire or temperatures above 130°C can cause an explosion.
- g) **Follow all instructions for charging and never charge the battery or the battery tool outside of the temperature range specified in the operating instructions.** Incorrect charging or charging outside of the approved temperature range can damage the battery and increase the risk of fire.

2.6 Service

- a) **Only have your power tool repaired by qualified professional staff and only with original replacement parts which can be available at HS Technik GmbH.** This ensures that the safety of the power tool is maintained.
- b) **Never perform maintenance on damaged batteries.** All maintenance of batteries may only be completed by the manufacturer or authorised customer service locations.

3 Important information about this tool

3.1 Handling the associated lithium Ion battery

- a) **Observe the operating instructions of the Li-Ion battery.**
- b) **If the battery will not be used over a longer period of time it may not remain on the charger or on the machine.** If an interruption of work of more than 3 hours is expected the battery must be removed from the tool. Otherwise it cannot be excluded that the battery will be permanently damaged.
- c) **For safety reasons the Li-Ion battery should not remain on the activated charger for longer than 36 hours.** Remove the battery from the charger as soon as possible after charging is complete.
- d) **An empty battery should not be in contact with the machine or a charger disconnected from the mains for a longer period of time.** In both instances low currents flow which totally discharge the battery and can permanently damage it.
- e) **Always charge the Li-Ion battery as soon as possible after use and do not store it when empty.** If the battery is stored separately from the tool and the charger it's capacity will remain constant for a long period of time (loss approx. 5 % per year).
- f) **Always transport the battery separately from the machine if possible.** This prevents accidental switching on of the machine as well as a total discharge of the battery.
- g) **Do not subject the Lithium-Ion battery to high temperatures (above 50°C) or direct sunlight.** If the battery gets warmer than 50°C during operation (charging or discharging) it must be immediately separated from the charger or the tool.
- h) **Under extreme use or temperature conditions batteries may leak. In the event of a leaky battery avoid contact with the skin or eyes.** The battery fluid is corrosive and can cause chemical burns to tissue. If the fluid comes into contact with the skin it must be washed immediately with soap and water and then rinsed with lemon juice or vinegar. If the fluid comes into contact with the eyes they must be rinsed for at least 10 minutes with water and a doctor must be consulted immediately.
- i) **Ensure that the Li-Ion battery does not fall or is not subjected to vibrations or shocks.**
- j) **Clean the battery contacts regularly with a cotton swab dipped in high-proof alcohol.**



NOTE

Lithium-Ion batteries have almost no self-discharge and have no memory effect. With proper and professional handling your tool will be reliably supplied with high energy density for a long period of time.

3.2 Information on the associated charger

- a) **Observe the operating instructions of the Li-Ion battery.**
- b) **The charger may not be connected to a step-up converter, generator or a direct current outlet.**
- c) **Ensure that the ventilation slots on the charger are not covered or blocked.**
- d) **Never charge the battery inside a carton or a closed container. The battery may only be charged in a well ventilated location.**
- e) **Do not charge the battery at temperatures BELOW 10°C or ABOVE 40°C.**
- f) **Do not store the power tool, the charger and the battery in locations in which temperatures are above 50°C. In particular, avoid direct sunlight.**

3.3 Structural modifications

No changes, additions or conversions to the power tool may be made without the approval of the manufacturer.

All conversion measures require written consent and confirmation by **HS-Technik GmbH**.



WARNING

In the event of the replacement of wear and tear parts only original replacement parts may be used.

3.4 Cleaning the device and disposal

Substances and materials used must be handled and disposed of properly, particularly when cleaning with solvents.

Do not throw the used battery into the household waste, fire or water, instead have it professional disposed of by a specialist or the manufacturer.



4 Start-up and use

DANGER

Risk of injury from damaged tools

Damaged tools can lead to injuries or damages.

- All damaged parts must be repaired before use.

Risk of injury from falling tools

Falling tools can lead to injuries or damages.

- Ensure you are self-belayed and have a secure footing.
- Avoid dropping the tool.



Risk of burns due to hot exhaust air

Hot air can escape through exhaust openings.

- Do not place any sensitive body parts directly in front of exhaust openings.

Risk of injury due to improper use

Improper use can lead to injuries or damage.

- Use the tool only for the intended purposes.

Risk of injury from substances

Substances such as lubricating oil and grease are flammable on the skin.

- Avoid contact with such substances.
- Should you still come into contact wash the affected area carefully.



NOTE

Maintain your tool with care. Follow the operating instructions during maintenance and cleaning. Keep the handle free of lubricants and dirt.



NOTE

Do not drop the tool, and do not let any other objects fall onto the tool. Protect it from impacts.



NOTE

Ensure that the tool does not come into contact with splashing water or oil.

4.1 Tool structure

1. Start button
2. Nose assembly with nose piece*
3. Multi-colour LED
4. 18 V Li-Ion battery
5. OLED Display
6. LED for work area lighting



* Nose piece and threaded mandrel are not included in the standard scope of delivery and must be ordered separately.

4.2 Operation

4.2.1 Inserting and removing the battery

- In order to insert the battery (1), align it so that it can be easily pushed onto the mounting provided along the plastic guide. After sliding it on completely, the fastening clip (2) must lock the battery firmly and properly into place in the tool housing.
- In order to remove the battery push the fastening clip on the front side of the battery down and pull the battery forward and off.
- Don't use force to install the battery. If the battery can not be easily pushed on it was not correctly positioned.



NOTE

Always push the battery all the way in until it locks into place with a click.



WARNING

Risk of injury from falling battery

If the battery is not correctly locked it can fall out and cause injuries.

- Always ensure that the battery is fully locked into place.



- 1) Battery
- 2) Fastening clip

4.2.2 Press start button

Pressing or actuating the start button starts or stops the tool.



NOTE

The battery riveting tool only starts when the battery has sufficient capacity.

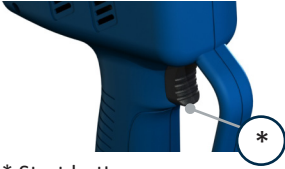

* Start button

4.2.3 Front LED



WARNING

Risk of injury from the light emitting diode

Looking directly into the light emitting diode can lead to eye injuries.

- Never look directly into the light emitting diode.

The LED on the front of the tool is used to illuminate the assembly area. After pressing the start button, the LED lights up. It turns off automatically after a few seconds. The afterglow time of the LED can be parametrised in the HST-Tool-Manager under „setup“ → „general“ → „energy&lighting“.



* Front LED

4.2.4 LED indicator at the back and sound signals

Circumferential indicator lights up green after setting, no sound signal

- Set stroke or set force was reached.
- The battery capacity is sufficient, the tool is ready for the next setting.

Circumferential indicator lights red after setting, sound signal appears

- NOK riveting, tolerance + or - from set stroke or set force
- If the indicator blinks yellow-red multiple times after setting then the battery is almost empty.



* LED Light indicator



NOTE

The tool will only start after a battery change if the battery has sufficient capacity.

4.2.5 OLED Display

- After a sufficiently charged battery has been pushed on the tool will start.
- After pressing the start button, the tool is initialised. The circumferential indicator on the rear side briefly lights up with multiple colours. A beep sounds and on the rear of the tool the display indicates the current status.
- The tool is now ready for use.
- After several seconds without actuation the display will dim. After longer downtime the tool will switch into standby mode.

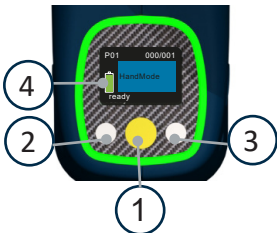

1. Button for menu activation and selection as well as for the NOK confirmation
2. Button for decreasing value (-)
3. Button for increasing value (+)
4. State of charge display

4.2.6 Selection of threaded mandrel and nose piece



NOTE

The threaded mandrel (sleeve) and the nose piece must be selected in accordance with the blind rivet nut, blind rivet bolt or earthing pin used.

You can use the riveting tool for processing different sizes and materials. When doing so, note the exact specification of the blind rivet nut or the blind rivet bolt and adjust the threaded mandrel (sleeve) and nose piece.

Blind rivet nuts	M3 – M10
Blind rivet bolts	M3 – M8



- 1) Nose piece
- 2) Threaded mandrel



NOTE

Use only the appropriate nose assembly for your blind rivet nut or blind rivet bolt. Non-compliance may cause damage to riveting machine. Furthermore, material damages can result from a damaged thread. Do not use force, the traction the nose assembly as well as the blind rivet nuts and blind rivet bolts must be able to be tightened by hand.



NOTE

Assemble the nose assemblies only in accordance with the quick guides provided by HS-Technik GmbH.

4.2.7 Adjusting the nose piece

The nose piece must be adjusted to the blind rivet nuts to be processed. Screw open blind rivet nuts by hand so that 1 - 2 threads stick out of the nut, see Figure 1. Lock the nose piece in this position using the lock nut. With automatic spinning on the threaded mandrel should now be flush with the blind rivet nut.

With closed blind rivet nuts screw the nuts by hand as far as they will go, see Figure 2, and then lock the nose piece using the lock nut. With automatic spinning on the nut should now be optimally spun on.



NOTE

These figures are intended as a guide and must be proved in tests with the nuts used!

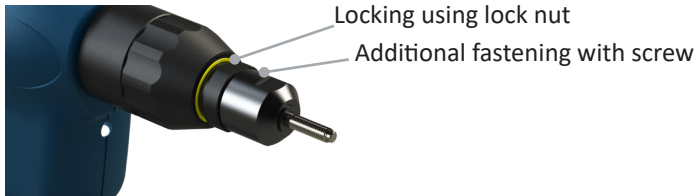

Fig. 1



Fig. 2

4.2.8 Set blind rivet nuts

NOTE

Always place the riveting tool at a right angle (90°) to the work surface to be riveted. An oblique placement leads to faulty riveting. Use only appropriate threaded mandrels (sleeves) and nose pieces for the rivet nut. An incorrect threaded mandrel (sleeve) and nose piece can lead to damage of the threaded mandrel (sleeve), tool, screw thread and components. You can find the size of the blind rivet nut in the rivet manufacturer's information.



NOTE

Before using the tool for the first time it must be programmed, see chapter 4.4 on page 37.





1. Place the rivet on the mandrel.
2. Press start button and thread on blind rivet nut. While doing so hold the blind rivet nut as far forward as possible and do not reach into the opening.
3. Hold the start button down until the blind rivet nut has been completely threaded on; the tool stops automatically.
4. Guide the rivet into the hole provided and let the tool process the blind rivet nut by actuating the start button.
5. Release the start button after the set process has ended.
6. The tool will automatically spin off after reaching the programmed set stroke or set force.

DANGER



Risk of injury from moving parts.

The nose assembly is a moving component that heats up during the process and can cause crushing.

- Under no circumstances should you touch parts of the nose assembly during the process.

4.2.9 Spinning off

If an incorrect nut or screw is spun on or it is not currently needed it can easily be spun off.

Clicking the yellow display button will make the notification „BACK“ appear in the display. The tool is ready to spin off the blind rivet nut or blind rivet bolt next.



To do this, hold it firmly at the front.

After spinning off the tool will automatically go back to its normal operating state.

DANGER



Risk of injury from moving parts.

The nose assembly is a moving component that heats up during the process and can cause crushing.

- Under no circumstances should you touch parts of the nose assembly during the process.

4.2.10 Tool tilted or blocked

If the tool or the blind rivet nut becomes tilted and stuck there is an option to release it on the back of the tool using a size 4 mm Allen key after the battery has been removed. To do this, place the Allen key in the opening provided (1) and turn it counter-clockwise. Always keep a firm hold on the tool.



DANGER



Risk of injury from rotating / falling parts.

If the Allen key remains in the tool, it creates significant risk of injury.

- Prior to operation ensure that the Allen key has been removed.

4.2.11 Overload

In order to avoid damages as a result of excess temperatures during continuous operation it is important to observe sufficient break times during the installation process.

If the tool should go into an automatic shut-down (TEMP FET) as a result of excessive temperatures the break times should be reviewed and adjusted.



Continued work is only possible after a cooling off period in order to protect the tool from lasting damage.

4.2.12 Standby and Shut-down mode

After approx. 10 minutes without actuation → the tool switches to standby mode
The tool starts up again by briefly tapping on the start button.

After another approx. 30 minutes without actuation → automatic shut-down
Start-up by pressing the start button if the battery has not yet been removed or right after sliding the battery back on. Both are only possible if the battery has sufficient charge capacity.



NOTE

In the case of longer period of non-use (longer than 3 hours) the battery must be separated from the tool in order to prevent deep discharge of the battery.

4.2.13 Charge state of the battery



NOTE

The tool will only start if the battery has sufficient charge capacity.

When fully charged, the battery will display the charge state on the display on the left side as a green battery symbol. As the battery voltage decreases the colour of the symbol will change to yellow and then red. When it reaches red an additional warning signal will sound, the display will read „warn batt“ and recommend changing the battery. After several additional installations, the tool will no longer start and the display will read „batt low 2“ with a crossed through battery. The battery must then, at the latest, be changed (chapter 4.2.1 on page 22).







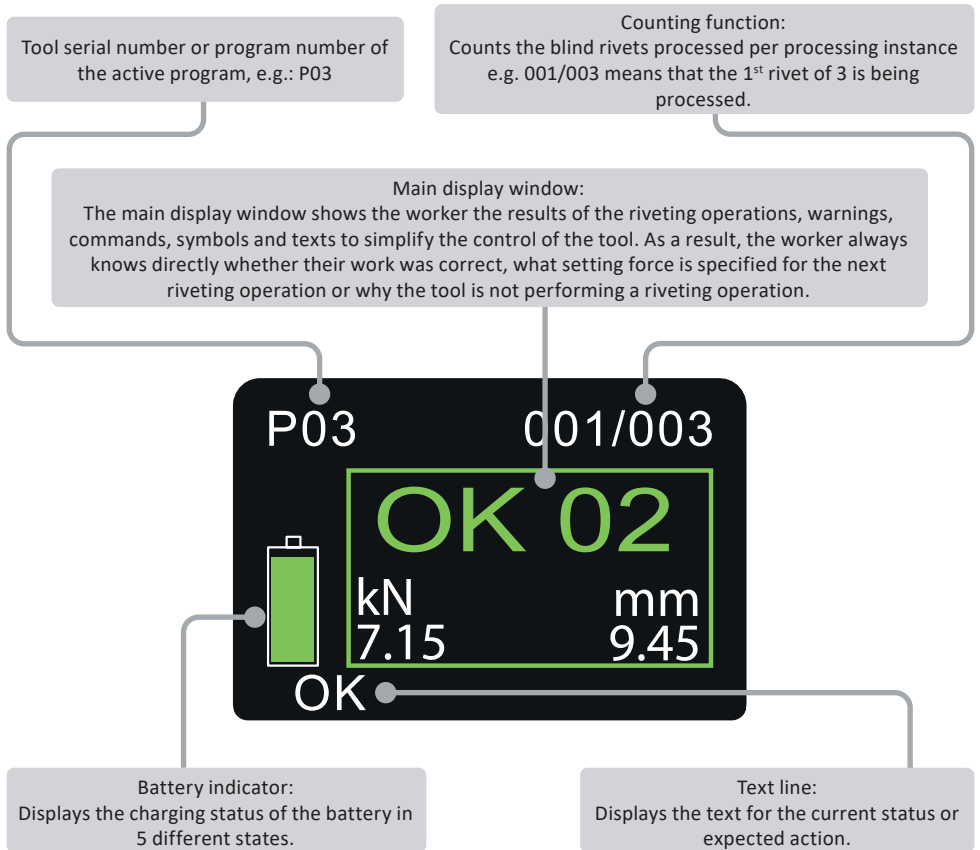



4.3 Display

The displays can be adapted in the HST-Tool-Manager so that the worker is shown, for example, exact values for riveting, stroke, only one OK or NOK, or the counting process. The displays can be shown in German or English. You can also set the unit for the output values (kN or lbf).

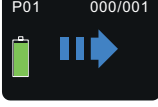
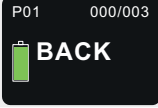

4.3.1 Display notifications

Display notifications	Meaning
	Battery state of charge: 50 % - 100 %
	Battery state of charge: 30 % - 50 %
	Battery state of charge: 10 % - 30 %
	Battery state of charge: 5 % - 10 %
	Battery state of charge: less than 5 %
	The tool is ready for use.
	If a stop is programmed between two program steps, this display will indicate that the Start button needs to be pressed again. Alternatively, it is possible to unscrew a blind rivet nut by pressing the yellow display button.
	The spinned-on blind rivet nut can be spinned off. Hold the blind rivet nut (not by hand). This option is only possible if a stop is programmed between the spinning on and the riveting process.
	The tool has been restarted successfully. By setting the trigger signal, the tool moves to its starting position and checks the tool for functionality. Then the tool is ready for use.
	Product ID must be scanned before the tool is enabled. Symbol can be represented as an aeroplane or a car.

Display notifications Meaning

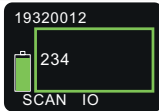

The scan of the barcode with the number "234" was successful.

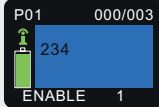

The tool is enabled for three rivet nuts with program 1. "234" corresponds to the barcode scanned for the enabling.

HST-Tool-Manager display setting:
Signals - OLED-display - Enable display: Barcode

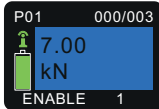

The tool is enabled for three rivet nuts with program 1. 7.00 kN corresponds to the target force from program 1.

HST-Tool-Manager display setting:
Signals - OLED-display - Enable display: Target value

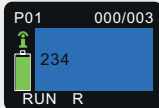

The tool is enabled for three rivet nuts with program 1. The riveting process is currently in progress. This is indicated by "Run R". "234" corresponds to the ID of the riveting.



Select the scanner to scan the Wi-Fi settings in the Setup menu.
Setup menu settings in the HST-Tool-Manager:
General - Functions - Setup menu - Scanner selectable



After selecting the scanner in the Setup menu with the start button, the selection must either be confirmed or discarded with the white display keys.

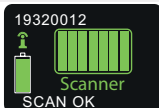

The scanning of the Wi-Fi settings was successful.

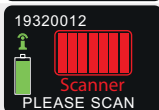

The scanning of the Wi-Fi settings was not successful.



Tool requires acknowledgement after NOK setting process.

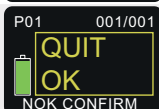

NOK setting process successfully acknowledged.

Display notifications Meaning



The tool is not enabled.

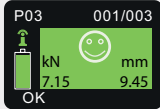

The first of three rivet nuts was successful. Achieved force 7.15 kN and a stroke of 9.45 mm. This message is also available as a NOK notice.

HST-Tool-Manager display setting:
Signals - OLED-display - Display of results: Smiley



The first of three rivet nuts was successful. Achieved force 7.15 kN and a stroke of 9.45 mm. This message is also available as a NOK notice.

HST-Tool-Manager display setting:
Signals - OLED-display - Display of results: Force



The first of three rivet nuts was successful. In the visualisation area, the counter decreases as the remaining number of rivets is displayed. This message is also available as a NOK notice.

HST-Tool-Manager display setting:
Signals - OLED-display - Display of results: Counter

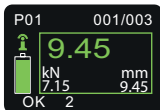

The first of three rivet nuts was successful. Achieved force 7.15 kN and a stroke of 9.45 mm. This message is also available as a NOK notice.

HST-Tool-Manager display setting:
Signals - OLED-display - Display of results: Stroke max.

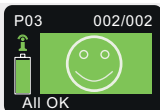

All three setting processes were successful.

HST-Tool-Manager display setting:
Signals - OLED-display - Display of results: Big smiley

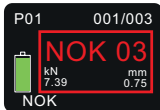

Example of the NOK setting process:

Process 1 NOK, 2 processes left. If NOK acknowledgement is activated, the display must be acknowledged by pressing the yellow display button.



The battery voltage can be displayed in the Setup menu under "features".



Tool is in idle mode. It can be reactivated by pressing the Start button.

For NOK results, the visualisation area is framed in red and the green result display is also red.

Display notifications Meaning



The tool searches for the specified network.



The tool has found the network and connects to it.



The tool has successfully connected to the network.



Maximum temperature of the motor exceeded. Allow the tool to cool down and check break times. If the error persists, contact the manufacturer.



Maximum logic voltage exceeded.
Tool must be repaired!



Tool cannot connect to the network.

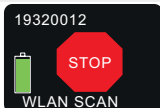

Tool could not find the set network.



Tool is in the wrong IP group.



Maximum permissible force exceeded, contact the manufacturer.

Display notifications Meaning



Maximum permissible current exceeded, contact the manufacturer.



If the maximum temperature of the control unit is exceeded, contact the manufacturer.

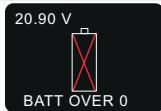

Maximum battery voltage exceeded.

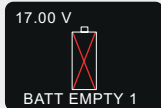

Battery voltage too low.



Tool must go for servicing and is only enabled again after confirmation by the service team.



Tool must be calibrated and is only enabled again after calibration.



Service interval for the threaded mandrel has been reached and it must be exchanged. The service notification must be reset by the service team in the HST-Tool-Manager.

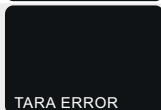

Sensor value error.
Contact manufacturer, tool must be checked.

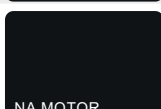

Motor does not start correctly. Motor faulty or incorrect programming. Check the last step of your program in the pulling direction. During this step, Force_{actual} must be activated. Nominal value of the tool must be entered.

4.4 HST-Tool-Manager

This excerpt shows only the most important functions for this tool type. A complete guide for the HST-Tool-Manager is available for you to download on our website.

Download the current version of the HST-Tool-Manager in the downloads area on the HS-Technik website www.hs-technik.com.

NOTE



Always use the most recent version of the HST-Tool-Manager from the website. The HST-Tool-Manager is backward compatible, i.e. it can also read and process older tool versions. If an update of your tool is necessary the HST-Tool-Manager will inform you.

1. Start the HST-Tool-Manager by double clicking the HST-Tool-Manager icon:

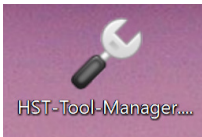

2. Log-in with the required User, a list of the passwords can be requested from HS-Technik (support@hs-technik.com).

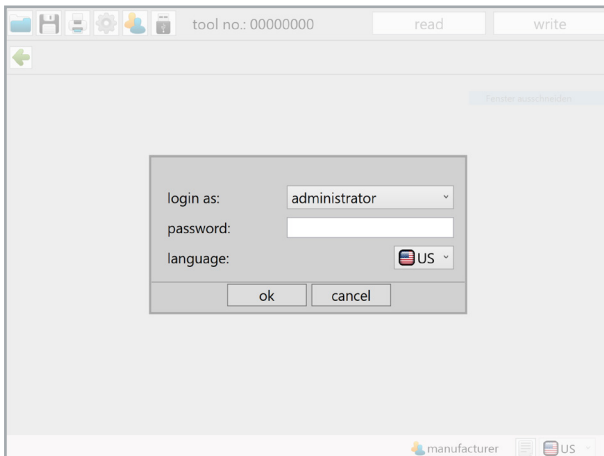

3. Insert the USB cable included into the Mini-B socket at the bottom of the tool and the opposite end into an open USB interface on your laptop / tablet / PC.



4. Click on the „read“ button on the top right.

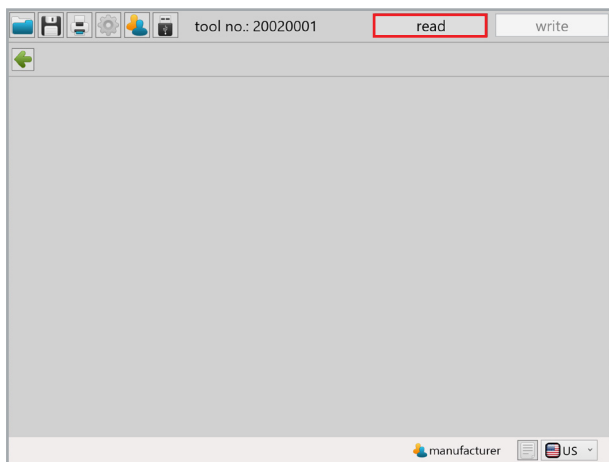

5. The HST-Tool-Manager will now read the settings from your tool and will display its progress using a green bar. At the end the tool overview will be displayed.

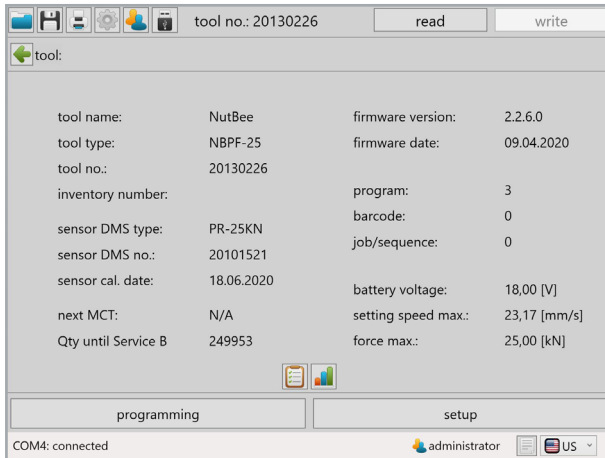

4.4.1 Setup

Clicking on setup takes you to the tool setup menu. Here, for example, the display, LED display and energy savings settings can be parametrised.

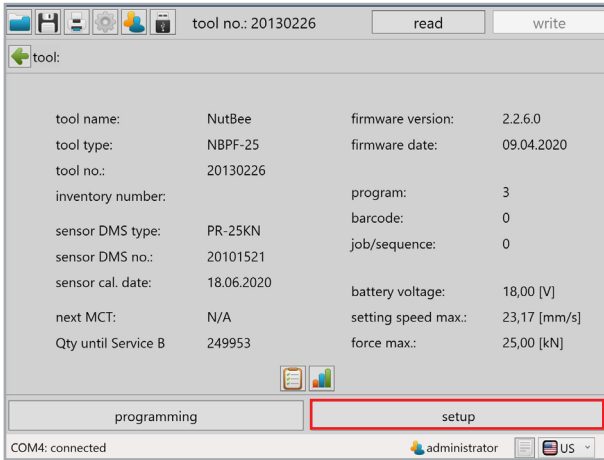

4.4.2 General → Process control

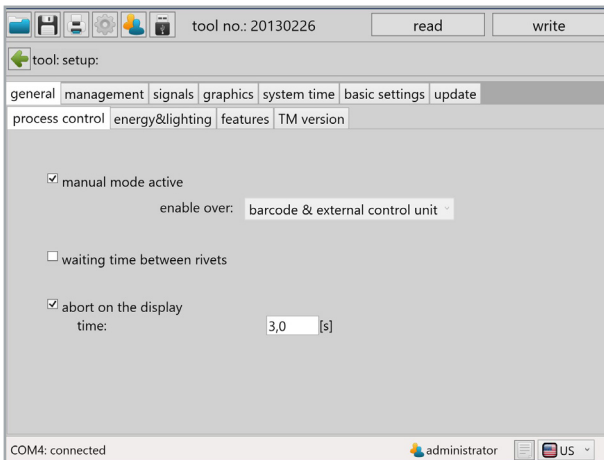

„manual mode active“ If the checkbox is activated, the tool works in manual mode. In other words, the standard program (yellow star) is always executed. In this mode, the counting function, Wi-Fi and barcode are deactivated.

„enable over“

Use the drop-down menu to select how the tool is to be enabled. To use this function, manual mode must be deactivated.

- „trigger“

The start button must be pressed 3 times in quick succession to enable the tool. The tool then works in the standard program with the counter activated.

- „time“

A time must be entered after which the tool is enabled. The tool then works in the standard program with the counter activated.

- „trigger & time“

A combination of the functions described above. The condition that is reached first enables the tool. The tool then works in the standard program with the counter activated.

- „barcode“

Activates the barcode scanner in the tool. A barcode must be scanned to enable the tool. For more information on programming barcodes, see the HST-Tool-Manager's operating instructions.

- „external control unit“

Activates the Wi-Fi in the tool. The tool is now enabled by an external controller. Without being enabled, the tool is locked.

- „barcode & external control unit“

Activates the barcode scanner and Wi-Fi. The tool scans a barcode which is then sent to the external controller. Based on the scan, the tool is enabled via Wi-Fi by the external controller.

„waiting time between tightenings“ If the function is activated, a time must be entered for the waiting time between two riveting operations. For this time, the tool is without function between the rivets and does not start up.

„abort on the display“ If the function is activated, a time must be entered for the job to be cancelled. The yellow menu key must be pressed for this time to cancel a job.

4.4.3 General → energy & lighting

Here you can parametrise the energy saving options and the LED lighting.

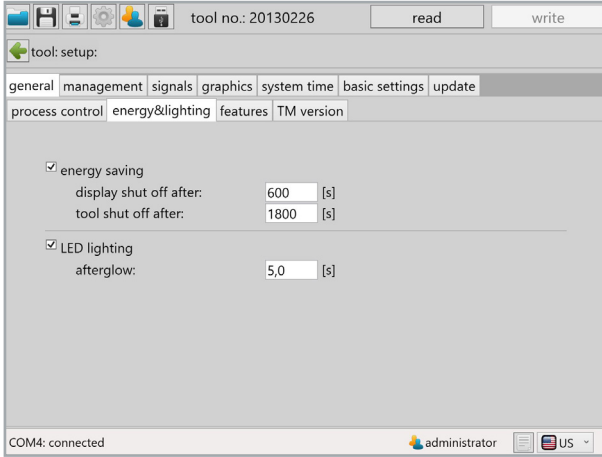

„energy saving“ The energy saving options can be activated or deactivated with the check-box.

„display shut off after“ Time in seconds without action after which the OLED display of the tool will switch off and the screen saver will activate.
Default value: 600 seconds (10 minutes)

„tool shut off after“ Time in seconds without action after which the tool turns off. Default value: 1,800 seconds (30 minutes)

„LED lighting“ The LED lighting can be activated or deactivated with the check-box.

„afterglow“ The amount of time the LED lighting continues to glow after completion of the work process.



NOTE

In systems in which the tool is operated via Wi-Fi, it must be checked whether the functions „Display shut off after“ and „Tool shut off after“ must be deactivated by entering a "0".

4.4.4 General → features

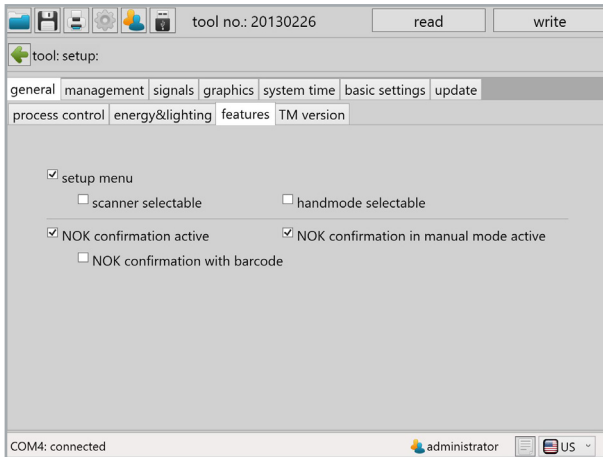

„setup menu“	Activates and deactivates the Setup menu via the display keys. When the function is active, the menu can be accessed by pressing and holding the yellow menu button on the display.
„scanner selectable“	If the function is active, the barcode scanner can be activated and deactivated via the Setup menu on the tool.
„handmode selectable“	If the function is active, you can activate and deactivate manual mode via the Setup menu on the tool.
„NOK confirmation active“	Activates and deactivates the NOK acknowledgement via the yellow menu button.
„NOK confirmation in manual mode active“	Activates and deactivates the NOK acknowledgement via the yellow menu button when the tool is operated in manual mode.
„NOK confirmation with barcode“	Activates and deactivates NOK acknowledgement with a barcode (QA-code). Further details on this function can be found in the HST-Tool-Manager's operating instructions.

4.4.5 General → TM version

The TM version will display the HST-Tool-Manager version required for this tool, at minimum, the version intended for the application, and the version last written on the tool.

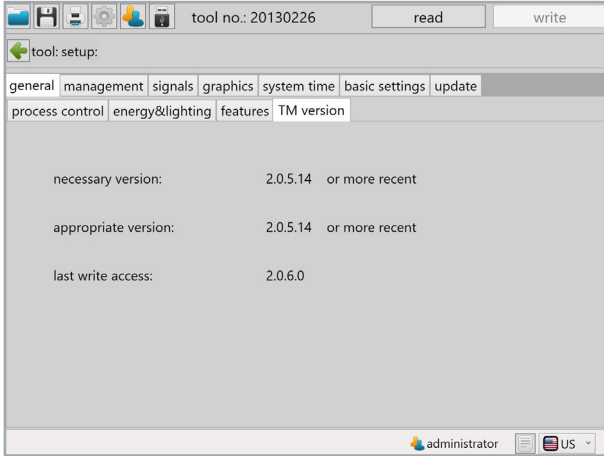

4.4.6 Management

The location on the management tab and the inventory number of the tool can be saved under administration.

Location max. 20 characters

Inventory number max. 40 characters

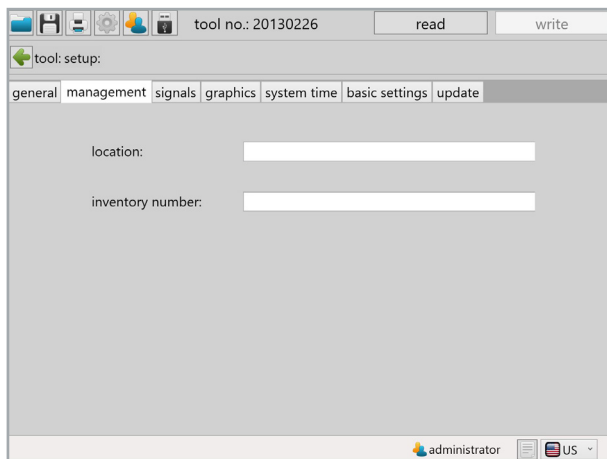

The screenshot shows a web application interface for tool management. At the top, there is a toolbar with icons for home, save, print, settings, user, and a power button. To the right of the toolbar, the text "tool no.: 20130226" is displayed, followed by "read" and "write" buttons. Below the toolbar is a breadcrumb trail: "tool: setup:". A horizontal menu contains tabs for "general", "management", "signals", "graphics", "system time", "basic settings", and "update", with "management" currently selected. The main content area contains two input fields: "location:" followed by a text input field, and "inventory number:" followed by a text input field. At the bottom right, the user is identified as "administrator" with a profile icon, and there is a language dropdown menu set to "US".

4.4.7 Signals → OLED-display

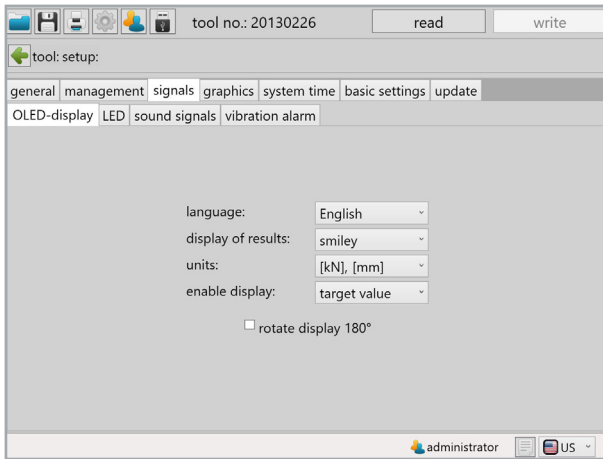

„language“

Select the language on the OLED display, German or English
Default: English

„display of results“

Select the display of results on the OLED display. **Smiley** displays the result as Smiley with the process values as small, **Force** displays the force reached as large (for NBLF-25), **Stroke** displays the stroke value reached as large (for NBLs-21), **Smiley large** displays the result as Smiley without process values.
Default: Smiley large

„units“

Selection of the units on the OLED display, SI units or imperial units
Default: SI units (kN and mm)

„enable display“

Selection of the display on the OLED display upon enabling. **Target value** shows the tool's target value, e.g. 10 kN. **Barcode** shows the scanned barcode, max. 9 characters. **Program table value** displays the selected table value. Default: Target value

„rotate display 180“

Selecting the check-box turns the display on the OLED display by 180°.

4.4.8 Signals → LED

The LED displays around the OLED display can be parametrised under the LED tab. The colour of the display can be changed by clicking on the coloured square.

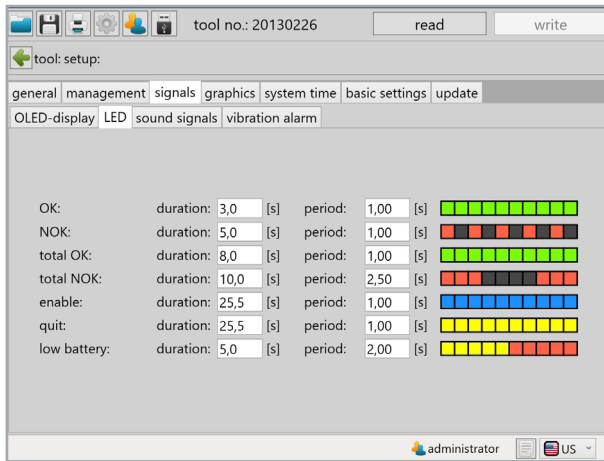

„duration“

The duration of the display in seconds, max. 25.5 seconds.

„period“

The duration of the sequence of the 10 parametrisable indicator fields. Period 1.00 seconds means that the 10 fields will be shown one after another within 1.00 seconds.

4.4.9 Signals → sound signals

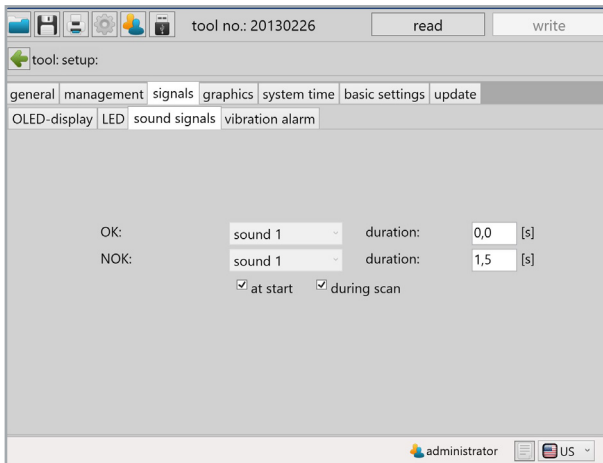

„duration“

For the duration the time of the sound signal for OK and NOK results will be parametrised in seconds, max. value 3.0 seconds.

„at start“

When the check-box is selected a signal will sound when the tool starts.

„during scan“

If the checkbox is selected, a beep sounds when a barcode is successfully scanned.

4.4.10 Signals → vibration alarm

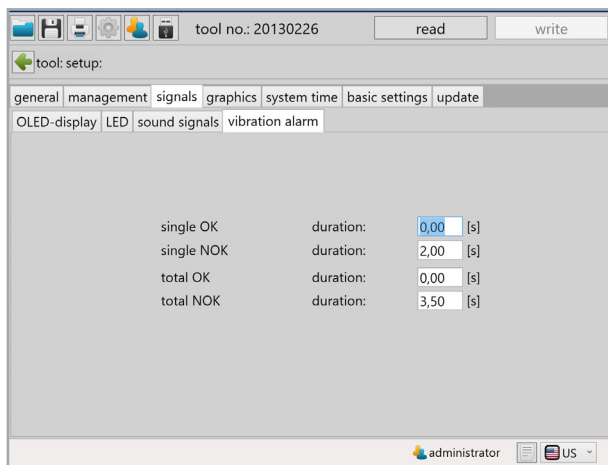

„duration“

The time entry defines how long the vibration alarm is active for. Default for NOK events, „Single NOK“ 2.00 seconds and „Total NOK“ 3.50 seconds.

4.4.11 Graphics

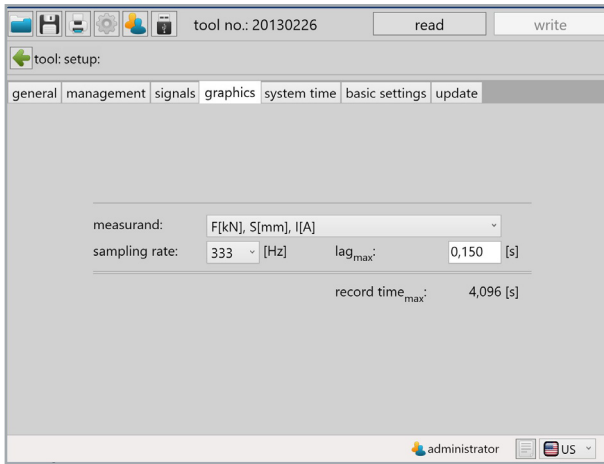

The „Graphics“ tab is used to define what is to be recorded and at what sampling rate.

„measurand“	F[kN] = Force in kN or Lbf S [mm] = Stroke in mm or inches I [A] = Current in amperes U [V] = Voltage in volts
„sampling rate“	Defines the default sampling rate at which the curve is recorded; default 333 Hz.
„lag _{max} “	Defines the time for which graphic recording continues after the target criterion has been reached. Recommended max. value 0.250 seconds, default: 0.150 seconds
„record time _{max} “	Shows how many seconds can be recorded per setting for the selected criteria. If the recording time is not sufficient, the beginning of the recording is discarded.

4.4.12 System time

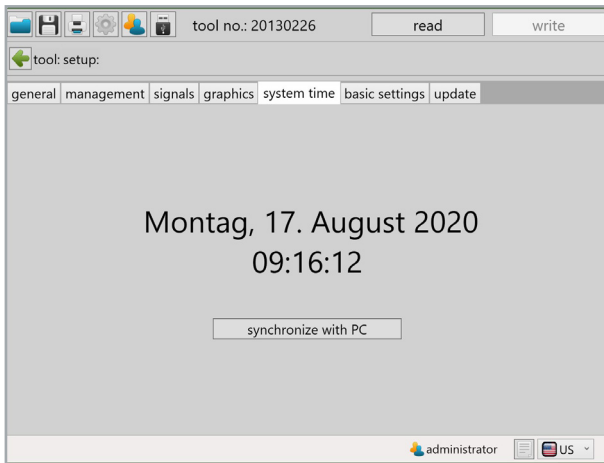

Under System time, the tool's Real Time Clock (RTC) can be synchronised with the time of the PC.

The RTC continues to be supplied with power internally via a capacitor even when the battery is disconnected from the tool. The internal memory for the RTC can be charged via USB as well as via the battery. The internal memory is fully charged after about 30 minutes. To ensure that the tool's time stamp is correct, the internal memory for the RTC must be completely reloaded after 2 weeks at the latest.

If there is a difference of more than 30 seconds between the system time and the time on the tool, a message will appear when the tool is read out.

4.4.13 Basic settings

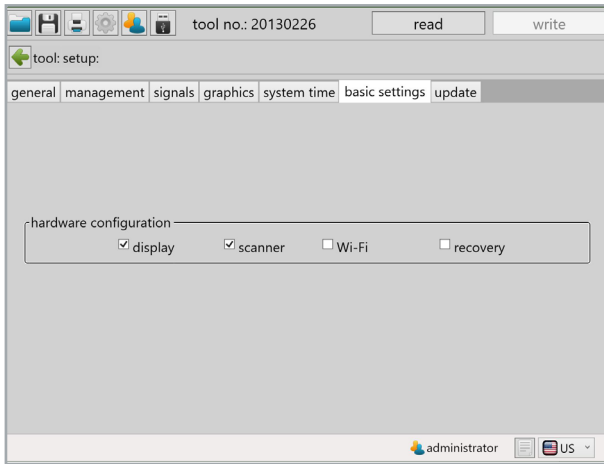

Accessories such as Wi-Fi and the barcode scanner as well as the recovery function can be activated under „Basic settings“.

Wi-Fi and the scanner are automatically activated when these functions are selected in „General → Process control → Enable over“.

„display“	Activates and deactivates the OLED display.
„scanner“	Activates and deactivates the barcode scanner. The prerequisite is that the tool is equipped with a barcode scanner.
„Wi-Fi“	Activates and deactivates the Wi-Fi module. The prerequisite is that the tool is equipped with Wi-Fi.
„recovery“	Activates and deactivates the recovery function. This function saves the current rivet counter in the event of a battery change and prompts the employee to work off the remaining quantity of the rivet counter after the battery change. When operating the tool in Wi-Fi systems, the recovery function should be switched off. Default: Deactivated

4.4.14 Update

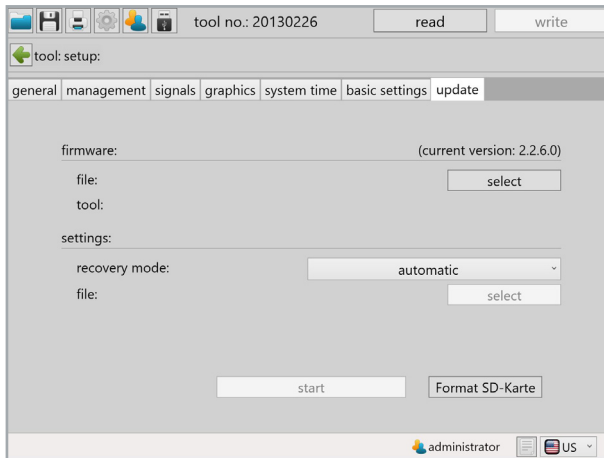

Select:

Click on select and find the .upd file provided by HS-Technik GmbH. Click „start“.

The progress of the update will be displayed using a status bar and confirmed at the end with „done“. The tool is now up-to-date with the current firmware and has the same settings as prior to the update.



NOTE

Do not pull out the USB cable during the update process!

4.4.15 Programming

Click on „Programming“ to access the Program settings menu. Here, for example, the speed, breakage detection and pressure control can be parametrised.

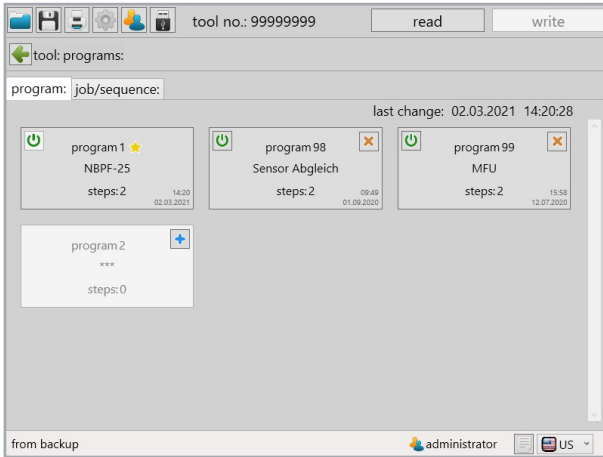

4.4.16 Program

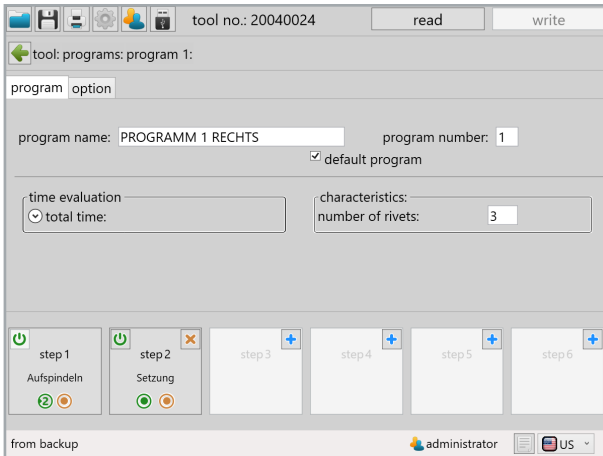

In program 1, up to 6 steps can be activated, each of which can be individually programmed. To parametrise a step individually, click on it. To create a new step, click on the small blue plus at the top right of the step.

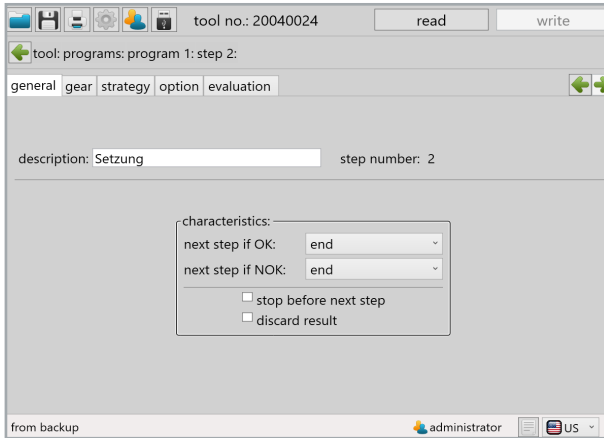

When you have clicked on a step, the summary appears in the picture above. The following settings can be made under „General“:

„next step if OK“	In the drop-down menu, you can select which action should follow if this step is completed OK, e.g. jump to the next step or end.
„next step if NOK“	In the drop-down menu, you can select which action should follow if this step is completed NOK, e.g. jump to the next step or end.
„stop before next step“	If the checkbox is selected, the tool stops when the step condition is reached (parametrised under Strategy).
„discard result“	If this option is activated, no evaluation is stored in the result file for this step.

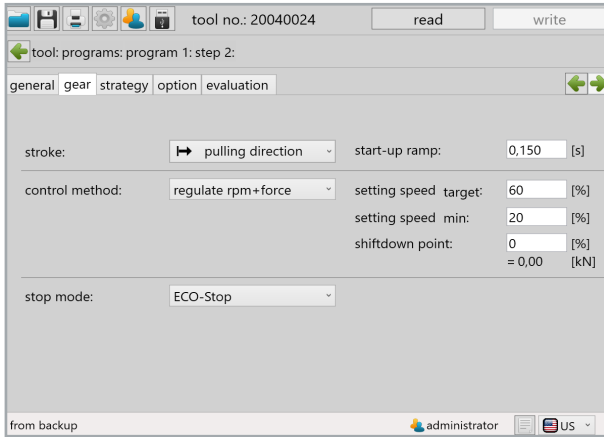

The settings for speed and pulling direction are made in the „Gear“ tab.

„stroke“

The direction of the stroke is parametrised here. The default is „Pulling direction“. The „Start position“ setting is only required for special applications. If you have any questions, please contact our support team: support@hs-technik.com

„start-up ramp“

This time defines the ramp with which the motor moves to the target speed, recommended value 0.1 - 0.2 seconds.

„control method“

Adjustment of the engine control. „Set rpm“ is the default setting. In the „regulate rpm“ control mode, the tool keeps the speed constant even under load.

- „regulate rpm“

The speed control corresponds to a closed control loop. The tool will try to maintain the set speed even under load.

- „set rpm“

The speed control corresponds to an open control loop. The tool will not readjust the speed under load.

- „rpm + force“

The speed control is dependent on the measured force. Only possible when F_{Target} (NBPF-25) is activated

- „setting speed_{target}“

Adjustment of the setting speed in %. Recommended setting for screwing-on, level 1, 50 %, for setting, level 2, 80 - 100 %.

- „setting speed_{min}“

Adjustment of the minimum setting speed

- „shiftdown point“

Specifies the force from which the setting speed is to be reduced.

Only available in the „rpm + force“ control mode.

„stop mode“

In the drop-down menu, it is possible to choose between „No stop“ for switching between two steps and „ECO stop“ for the last step.

The parameter for rivet setting are defined in the „Strategy“ tab.

The individual functions can be activated by clicking on the On/Off symbol. A green symbol means active, greyed out means inactive.

NBPS-21

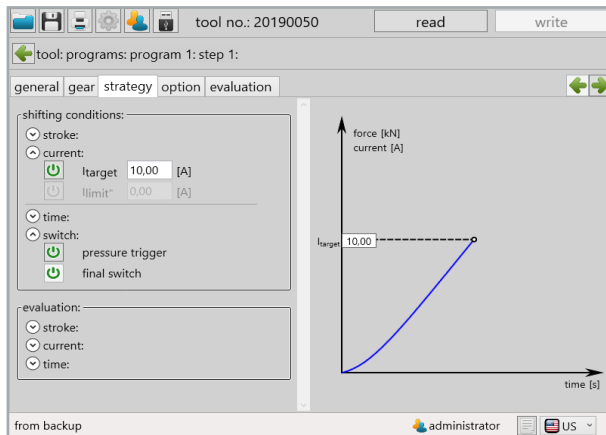

stroke

„ S_{target} “

S_{Target} describes the stroke that the tool should travel in this step. When this value is reached, the tool changes to the next step.

„ S_{limit} “

S_{Limit} describes the max. stroke the tool may cover in this step. When this value is reached, the tool stops and displays an NOK error message.

current

„ I_{target} “

I_{Target} describes the current that the tool should reach in this step. When this value is reached, the tool changes to the next step.

„I _{start} “	If I _{target} is activated, I _{start} appears. This value defines the point at which the stroke measurement for the setting step is to be started.
„I _{limit} “	I _{limit} describes the max. current that the tool can reach in this step. When this value is reached, the tool stops and displays an NOK error message.
„I _{limit} “	I _{limit} defines a lower limit of current which the tool is not allowed to fall below. Monitoring is only active once I _{start} is reached. If the current drops below I _{limit} after reaching I _{start} the process will be evaluated NOK.



DANGER

Risk of injury due to incorrect parametrisation

Incorrect parametrisation can lead to injuries or damage

- Settings may only be made by experienced users.

time

„T _{target} “	T _{target} describes the time for which the tool should run in this step. When this value is reached, the tool changes to the next step.
„T _{limit} “	T _{limit} describes the max. time that the tool can run in this step. When this value is reached, the tool stops and displays an NOK error message.

switch

„pressure trigger“	If the Pressure trigger function is activated in the step, the pressure trigger must be activated. Default: deactivated
„final switch“	The limit switch function must always be activated so that the tool cannot move onto the block.

evaluation

„stroke“	The stroke value determines in which stroke range the operating point must lie and evaluates the riveting process with OK or NOK.
„current“	The current value determines the current range in which the operating point must lie and evaluates the riveting process with OK or NOK.
„time“	The time defines the time range in which the operating point has to be in and evaluates the riveting process with OK or NOK.

NBPF-25

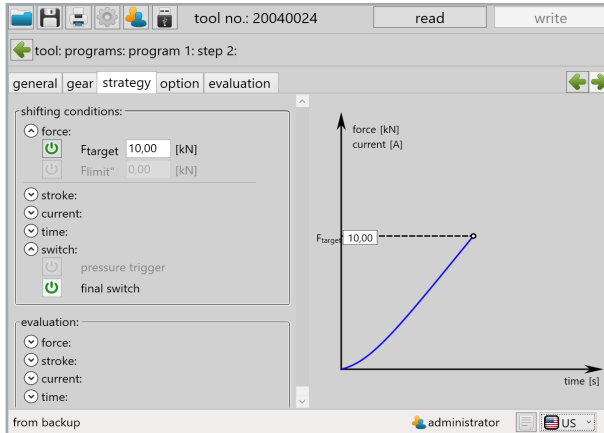

force

„ F_{target} “ F_{Target} describes the force that the tool should achieve in this step. When this value is reached, the tool changes to the next step.

„ F_{start} “ If F_{Target} is activated, F_{start} appears. This value defines the point at which the stroke measurement for the setting step is to be started.

„ F_{limit} “ F_{limit} describes the maximum force that the tool can achieve in this step. When this value is reached, the tool stops and displays an NOK error message.

„ F_{limit} “ " F_{limit} " describes the minimum force that must not be fallen short of during this step. Monitoring starts from F_{start} .

stroke

„ S_{target} “ S_{Target} describes the stroke that the tool should travel in this step. When this value is reached, the tool changes to the next step.

„ S_{limit} “ S_{limit} describes the max. stroke the tool may cover in this step. When this value is reached, the tool stops and displays an NOK error message.

current

„ I_{target} “ I_{Target} describes the current that the tool should reach in this step. When this value is reached, the tool changes to the next step.

„I_{start}“ If I_{Target} is activated, I_{start} appears. This value defines the point at which the stroke measurement for the setting step is to be started.

„I_{limit}“ I_{limit} describes the max. current that the tool can reach in this step. When this value is reached, the tool stops and displays an NOK error message.



DANGER

Risk of injury due to incorrect parametrisation

Incorrect parametrisation can lead to injuries or damage

- Settings may only be made by experienced users.

time

„T_{target}“ T_{Target} describes the time for which the tool should run in this step. When this value is reached, the tool changes to the next step.

„T_{limit}“ T_{limit} describes the max. time that the tool can run in this step. When this value is reached, the tool stops and displays an NOK error message.

switch

„pressure trigger“ If the Pressure trigger function is activated in the step, the pressure trigger must be activated. Default: deactivated

„final switch“ The limit switch function must always be activated so that the tool cannot move onto the block.

evaluation

„force“ The force value determines the force range in which the operating point has to be in and evaluates the riveting process with OK or NOK.

„stroke“ The stroke value determines in which stroke range the operating point has to be in and evaluates the riveting process with OK or NOK.

„current“ The current value determines the current range in which the operating point has to be in and evaluates the riveting process with OK or NOK.

„time“ The time defines the time range in which the operating point has to be in and evaluates the riveting process with OK or NOK.

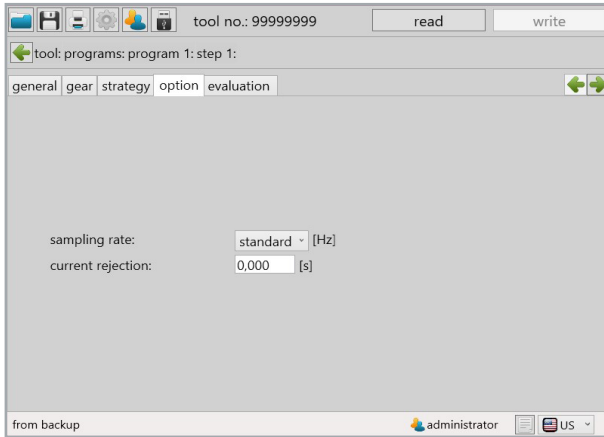

„sampling rate“

For each step, an individual sampling rate can be selected for the graphic recording. This allows the recording to be optimised. If "Standard" is selected, the step is recorded with the value set under "Settings" → "Graphics" → "Sampling rate". (See 4.4.11 Graphics on page 50)

„current rejection“

This function suppresses the starting current of the motor when using a current setting in the strategy.
Recommended value: 0.25 seconds.

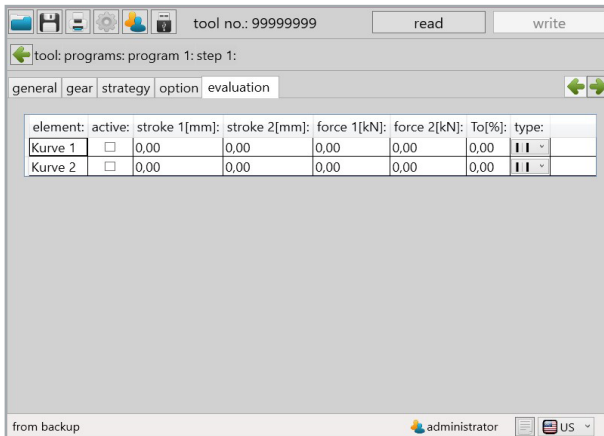

„evaluation“

Here you can define the stroke and force range to be measured for each step.

4.4.17 Program → Option

The options for the program can be configured under Program Options.

NBPS-21

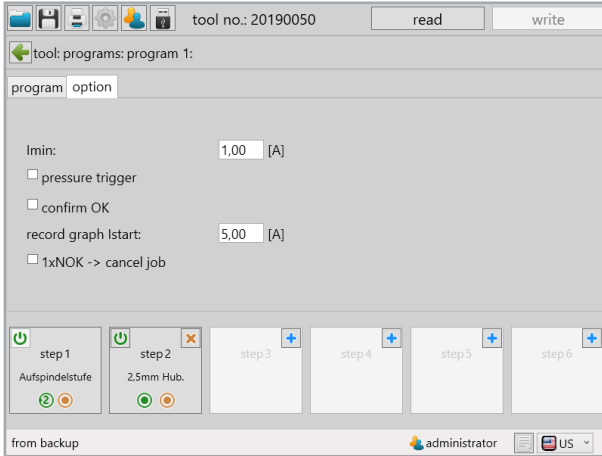

„I_{min}“

I_{min} describes the minimum current for this step. If a current below this value is reached, no rivet has been set. The tool shows "Blank stroke" or "Leerhub" on the display, depending on the language setting.



Display english (default)

„pressure trigger“

The pressure control ensures that the blind rivet can only be processed when the pressure control is activated. This prevents accidental triggering and ensures that the components to be processed are in contact with each other. Pressure control is only active if the checkbox is enabled.

„confirm OK“

If this checkbox is selected, an OK setting must be acknowledged

„record graph I_{start} “ If this checkbox is selected, graphic recording starts from the entered current value.

„1xNOK → cancel job“ If this checkbox is selected, the program is aborted in the event of an NOK.

NBPF-25

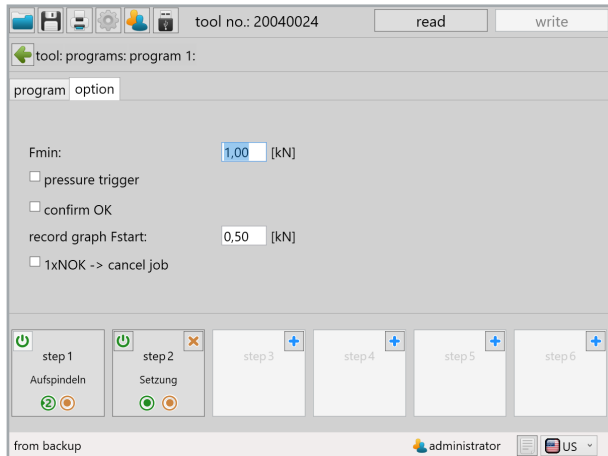

„ F_{min} “ F_{min} describes the minimum force for this step. If a force below this value is reached, no rivet has been set. The tool shows "Blank stroke" or "Leerhub" on the display, depending on the language setting (see pictures on page 62).

„pressure trigger“ The pressure control ensures that the blind rivet can only be processed when the pressure control is activated. This prevents accidental triggering and ensures that the components to be processed are in contact with each other. Pressure control is only active if the checkbox is enabled.

„confirm OK“ If this checkbox is selected, an OK setting must be acknowledged

„record graph F_{start} “ If this checkbox is selected, graphic recording starts from the entered force value.

„1xNOK → cancel job“ If this checkbox is selected, the program is aborted in the event of an NOK.

4.5 Maintenance and servicing

Apart from the regular cleaning and the inspection and maintenance of the threaded mandrel the battery blind riveting device is largely maintenance-free.

DANGER



Risk of injury as a result of improper handling!

Improperly executed work can lead to hazards.

- Repair, maintenance and care of riveting tools must be completed professionally.
- After the work, no risk for the operator should exist during proper use.
- The operator may only conduct the work described here.

4.6 Cleaning



NOTE

Observe the following information for cleaning your tool. Incorrect cleaning solutions or improper procedures when cleaning can lead to damage to the riveting device.

4.6.1 General information

Do not use any degreasing or corrosive cleaning solutions and no water. Do not spray any cleaning solutions, solvents or easily flammable materials into the openings of the housing! Clean the battery contacts and the battery connection on the tool with a cloth, cotton swab and a little alcohol when necessary.



4.6.2 Cleaning / replacement of the threaded mandrel

Loosen and remove the nose piece (1).

In order to clean or replace the threaded mandrel (2) pull back the silver locking ring (3) and loosen the mandrel by turning.

If the nose piece can not be loosened by hand it can be loosened by using two SW24 keys.

These components can be cleaned using a wire brush or a cloth. Any swarf should be removed. Then check the mandrel and replace if necessary.

Then reassemble the device in reverse order. While doing so ensure that the threaded mandrel is again locked into place flush with the locking ring.



4.6.3 Machine capability test (MCT)

We recommend an annual machine capability study for high quality standards and a long life span. This can be combined with maintenance and inspection of the overall tool.

The machine capability study can be completed by HS-Technik GmbH.

4.6.4 Service interval counter

The tool has an internal service interval counter which will inform the user of an inspection due. In this case you will receive the following notification in the display:



The service counters can be parametrised with the HST-Tool-Manager under the „Service“ user. The respective value entered will be multiplied by 1,000, i.e. when entering 10 the service notification will appear on the display after 10,000 sets. If you enter 0 the function is deactivated.

The recommended service intervals are saved in the tool ex works. We would be happy to inspect the tools for you after reaching the service interval.

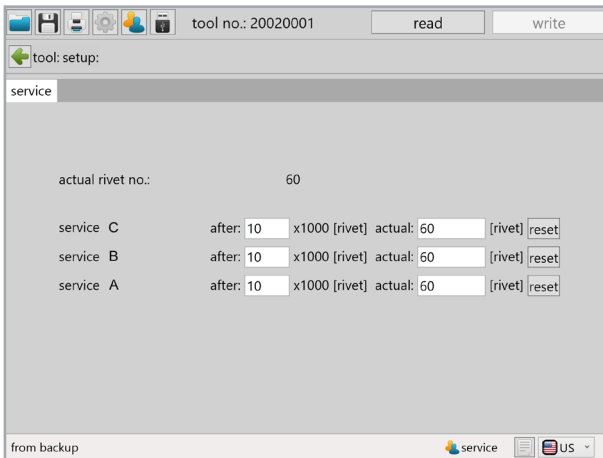

5 Storage

Observe the following information when storing riveters, chargers and batteries:

- Remove the battery when you are not using the riveting device.
- If you will not be using the battery for a longer period of time it should be stored, fully charged, in a dry, dust-proof area.
- Store the riveting device and charger in a dry environment protected against splashing water.
- Store the riveting device and charger in a well ventilated space and protected against exposure to dust.
- Ensure that the storage environment is free of aggressive chemicals and vapours.

6 Technical data

Description	NBPS-21	NBPF-25
Operating voltage	18 VDC	
Device stroke	21 mm	
Setting force	max. 25 kN	
Setting speed	max. 23 mm/s	
Noise emissions (L_{pA})	71 dB(A)	
Measurement uncertainty (K)	3 dB(A)	
Vibration (a_{nv})	< 2,5 m/s ²	
Measurement uncertainty (K)	1,5 m/s ²	
Operating altitude	< 2000 mNN	
Operating temperature	10 - 40 °C	
Storage temperature	0 - 50 °C	
Dimensions (L × W × H)	212 × 73 × 270 mm	
Weight without battery & nose assembly	approx. 2,0 kg	
Weight with battery 2.5 Ah	approx. 2,3 kg	
Weight with battery 5.0 Ah	approx. 2,6 kg	
HST-PR-1825 battery	Li-Ion, 18 V, 2,5 Ah	
HST-PR-1850 battery	Li-Ion, 18 V, 5,0 Ah	
HST-PR-2830 charger	220 - 240 VAC, 50 - 60 Hz, 65 W	
Blind rivet nuts	M3 - M10	
Blind rivet bolts	M3 - M8	

The values given for noise emissions and vibration were measured using a standardised test method and can be used for comparison with other power tools. They can also be used for a preliminary estimate of the load.



NOTE

The actual emissions can differ from the above information depending on the type and manner of use of the tool and, in particular, depending on the type of work-piece.

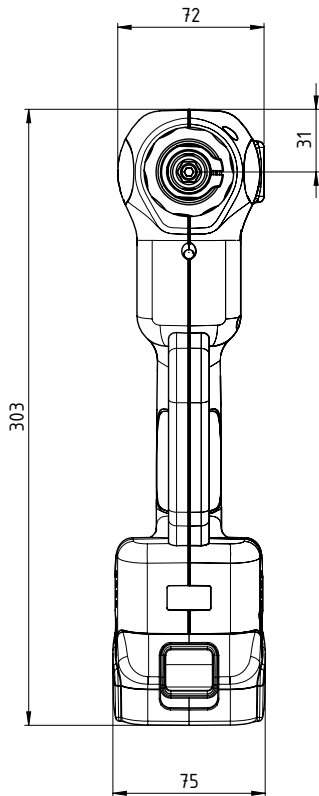
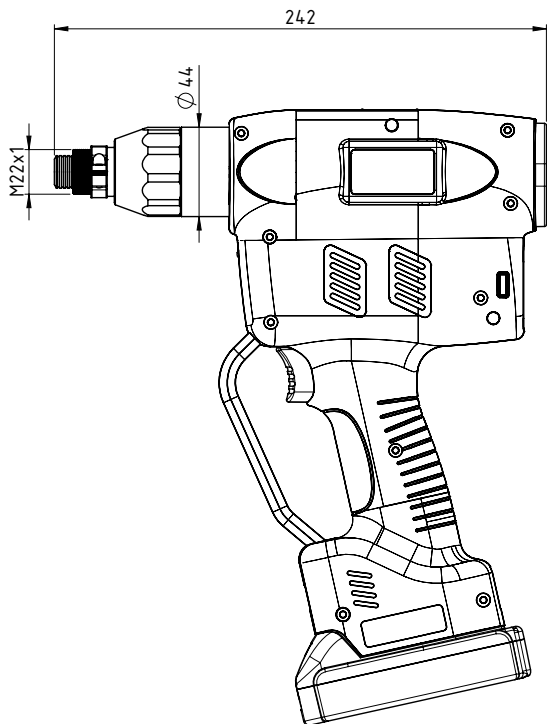

Specifications in mm
Not shown to scale

7 Troubleshooting and Fault repair

The NutBee by HS-Technik is a very stable and long-lasting tool.

Please contact HS-Technik GmbH if unknown errors occur.

Repairs:

Telephone: +49 (0)7628 / 91 11-0

E-mail: repaircenter@hs-technik.com

Programming:

Telephone: +49 (0)7628 / 91 11-0

E-mail: support@hs-technik.com

Please note the following information:

- Serial number of the riveting device (see battery compartment of the device)
- What error has occurred?
- Display
- When did the error first appear?
- What have you done to fix the error?

We reserve the right to make errors, technical changes to our products and changes to the delivery program in the course of further development.

CE Declaration of conformity

We, the manufacturer, hereby declare that the named tool complies with the essential protection requirements of the listed EU directives regarding design and construction type.

The prerequisite for this is the intended use of the tool as well as compliance with the installation and commissioning instructions.

If the product or its accessories are modified without our consent, this declaration becomes invalid.

Tool description: Programmable cordless blind riveting tool

Type designation: NBPx-xx

Manufacturer: HS-Technik GmbH
Im Martelacker 12
D-79588 Efringen-Kirchen

Directives: 2006/42/EU
2014/30/EU

Applied standards: EN 62841-1:2015+AC:2015, EN 62841-2-2:2014
EN 61000-6-3:2007+A1:2011+AC:2012
EN 61000-6-2:2005+ AC:2005
EN 55014-1:2006+A1:2009+A2:2011
EN 55014-2:1997+ AC:1997+A1:2001+A2:2008

HS-Technik GmbH
Im Martelacker 12, D-79588 Efringen-Kirchen

February 2021



Florian Hanke
CEO

HS-Technik GmbH
High - System - Technik

HS-Technik GmbH
Im Martelacker 12
D-79588 Efringen-Kirchen

Telephone: +49 (0)7628 - 91 11-0
Fax: +49 (0)7628 - 91 11-90
E-mail: info@hs-technik.com
Internet: www.hs-technik.com