

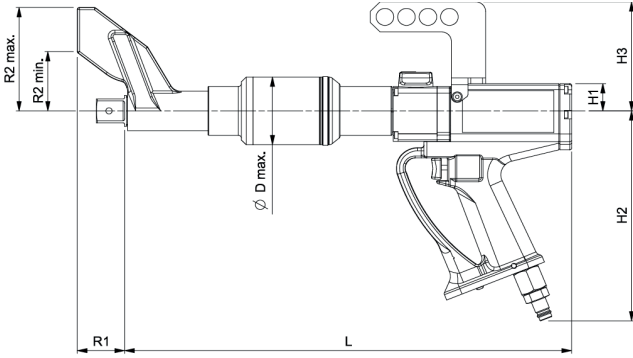

## PTME Serisi Havalı Bijon Tork Anahtarları - [200 - 2.000 N.m]

PTME Wheel Pneumatic Torque Wrenches - [200 - 2.000 N.m]



- » Standart seride hassasiyet  $\pm 5\%$
- » Dijital seride hassasiyet  $\pm 2\%$
- » Minimum tork kapasitesi 200 N.m
- » 2.000 N.m kadar 7 farklı model
- » Sıkma ve sökme işlemlerine uygun yapı
- » Yumuşak başlatma, tetik ile kademeli hız ayarı
- » Vites kutusu tutma kolundan bağımsız döner
- » Sessiz (85db) , darbesiz çalışma, hızlı torklama
- » Hedeflenen tork değerine ulaştığı zaman durur
- » Ağır vasıta ve bijon uygulamaları için tasarlanmıştır
- » Norbar fabrika kalibrasyon belgesiyle sevk edilir
- » Teknik destek ve yedek parça hizmeti

- » Accuracy up to  $\pm 5\%$  for standard series
- » Accuracy up to  $\pm 2\%$  for standard series
- » Minimum torque 200 N.m
- » Maximum torque 2.000 N.m
- » Clockwise and counterclockwise operation
- » 'Soft Start' allows gradual and safe reaction location
- » Gearbox can rotate independently from the handle
- » Quiet - less than 85 dB(A) when under load
- » Clear indication of successful joint application
- » Designed to meet the needs of the commercial vehicle
- » Supplied with Norbar house calibration certificate

### Standart Havalı Bijon Tork Anahtarları / Pneumatic Truck and Bus Wheel Torque Wrenches

Parça Part	Tork Aralığı Torque Range		Kare Sürücü Square Drive	Devir Hızı Output Speed	Ağırlık Weight	Ölçüler (mm) Sizes							
	No.	N.m				lbf.ft	inch	rpm	kg	D	H1	H2	H3
18140.B06	200 - 1.000	147 - 738	3/4"	122	7.2	72	29	224	116	403	81	63	110
18149.B08	200 - 1.000	147 - 738	1"	122	7.2	72	29	224	116	403	81	63	110
18141.B08	400 - 2.000	295 - 1.475	1"	58	7.7	72	29	224	116	458	49	63	115

### Dahili Dijital Kontrollü Havalı Tork Anahtarları / Pneumatic Truck and Bus Wheel Torque Wrenches With Internal Control

Parça Part	Tork Aralığı Torque Range		Kare Sürücü Square Drive	Devir Hızı Output Speed	Ağırlık Weight	Ölçüler (mm) Sizes							
	No.	N.m				lbf.ft	inch	rpm	kg	D	H1	H2	H3
18142.B06	200 - 1.000	147 - 738	3/4"	122	8.5	72	29	224	116	403	81	63	110
18143.B08	400 - 2.000	295 - 1.475	1"	58	9	72	29	224	116	458	49	63	115

### Harici Dijital Kontrollü Havalı Tork Anahtarları / Pneumatic Torque Wrenches With External Control

Parça Part	Tork Aralığı Torque Range		Kare Sürücü Square Drive	Devir Hızı Output Speed	Ağırlık Weight	Ölçüler (mm) Sizes							
	No.	N.m				lbf.ft	inch	rpm	kg	D	H1	H2	H3
18144.B06	200 - 1.000	147 - 738	3/4"	122	8.5	72	29	224	116	403	81	63	110
18145.B08	400 - 2.000	295 - 1.475	1"	58	9	72	29	224	116	458	49	63	115



16074

Tork Kontrol ve Yağlama Ünitesi  
Torque Wrench Lubro Control Unit