



## Kasetli Hidrolik Tork Anahtarları

### Low Clearance Hydraulic Torque Wrenches



- »  $\pm 3\%$  hassasiyetle torklama işlemi.
- » Sıkma ve sökmeye uygun tasarım.
- » 47.450 N.m'ye kadar 6 farklı model.
- » Dar bölgelere uyumlu düşük yarıçap.
- » Küçük hacimli, dayanıklı uzun ömürlü.
- » 30 – 155 mm arası altıgen kaset seçeneği.
- » 30° dönüşlü çark sistemiyle daha hızlı torklama.
- » 180° çok pozisyonlu dönebilir yağ giriş bağlantısı.
- » Türkiye'de servis ve kalibrasyon desteği.

- » Torque accuracy:  $\pm 3\%$  across full stroke.
- » Designed to tighten and loosen
- » Low profile design and small operating radius.
- » Robust and easy to disassemble for maintenance.
- » Wide range of interchangeable cassettes.
- » Fast release drive unit for quick exchange of cassette.
- » 30° rotation angle and rapid return stroke.
- » Repair, maintenance and calibration services.

Parça Part	Tork Gücü (N.m) Torque Range		Anahtar Nut A/F	Ağırlık (kg) Weight		Ölçüler (mm) Dimensions					
	Min	Max		mm	Piston Cylinder	Kaset Cassette	H1	H2	C	W1	E
LX03	270	2.760	30 – 60	1.4	2.1 – 2.3	141	109	148	32	24	20
LX06	560	5.660	36 – 85	2	3.7 – 4.5	167	136	178	41	33	20
LX11	1.150	11.480	50 – 105	3	7.9 – 9.3	205	172	208	53	42	25
LX21	2.080	20.780	65 – 115	5	13.6 – 15.1	240	207	253	63	50	20
LX31	3.050	30.500	75 – 135	7.7	21.9 – 25.0	266	227	297	77	48	35
LX47	4.750	47.450	80 – 155	11.4	31.8 – 36.7	301	268	345	91	69 – 73	50

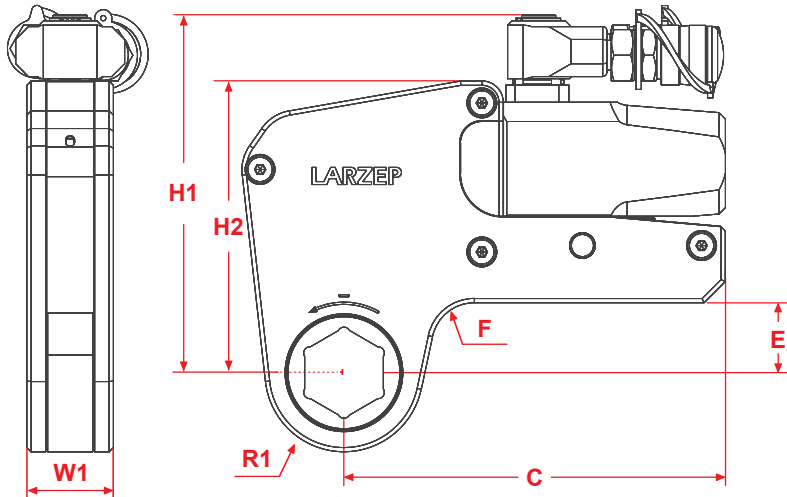

Kaset seçenekleri için bir sonraki sayfayı inceleyiniz.  
Check the next page for hexagon links options.





## LX Serisi Hidrolik Tork Anahtarları Kasetleri

LX Series Hydraulic Torque Wrench Cassettes

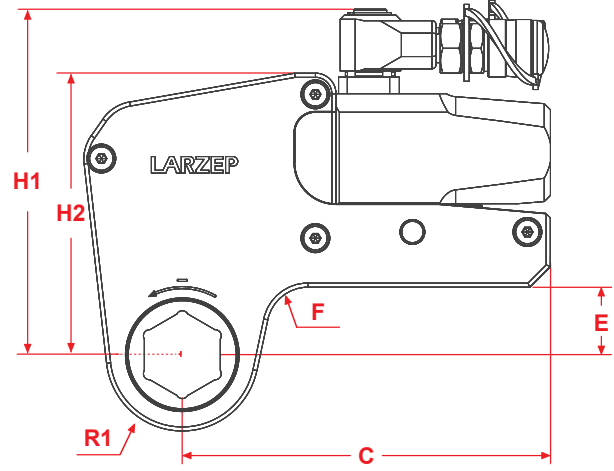

LX03				
No.	Saplama Ölçüsü	Anahtar Nut A/F	R1	Max. Tork
#	Bolt Size	mm	mm	N.m
LX03H030	M20	30	31	2.765
LX03H032	M22	32	31	2.765
LX03H036	M24	36	31	2.765
LX03H041	M27	41	34	2.765
LX03H046	M30	46	34	2.765
LX03H050	M33	50	39	2.765
LX03H055	M36	55	42	2.765
LX03H060	M39	60	45	2.765

LX06				
No.	Saplama Ölçüsü	Anahtar Nut A/F	R1	Max. Tork
#	Bolt Size	mm	mm	N.m
LX06H036	M24	36	37	5.660
LX06H041	M27	41	37	5.660
LX06H046	M30	46	40	5.660
LX06H050	M33	50	42	5.660
LX06H055	M36	55	44	5.660
LX06H060	M39	60	47	5.660
LX06H065	M42	65	50	5.660
LX06H070	M45	70	53	5.660
LX06H075	M48	75	55	5.660
LX06H080	M52	80	59	5.660
LX06H085	M56	85	62	5.660

LX11				
No.	Saplama Ölçüsü	Anahtar Nut A/F	R1	Max. Tork
#	Bolt Size	mm	mm	N.m
LX11H050	M33	50	45	11.480
LX11H055	M36	55	48	11.480
LX11H060	M39	60	51	11.480
LX11H065	M42	65	56	11.480
LX11H070	M45	70	56	11.480
LX11H075	M48	75	58	11.480
LX11H080	M52	80	61	11.480
LX11H085	M56	85	66	11.480
LX11H090	M60	90	74	11.480
LX11H095	M64	95	74	11.480
LX11H100	M68	100	80	11.480
LX11H105	M72	105	80	11.480

LX21				
No.	Saplama Ölçüsü	Anahtar Nut A/F	R1	Max. Tork
#	Bolt Size	mm	mm	N.m
LX21H070	M45	70	59	20.785
LX21H075	M48	75	62	20.785
LX21H080	M52	80	65	20.785
LX21H085	M56	85	70	20.785
LX21H090	M60	90	75	20.785
LX21H095	M64	95	75	20.785
LX21H100	M68	100	81	20.785
LX21H105	M72	105	81	20.785
LX21H110	M76	110	88	20.785
LX21H115	M80	115	88	20.785

LX31				
No.	Saplama Ölçüsü	Anahtar Nut A/F	R1	Max. Tork
#	Bolt Size	mm	mm	N.m
LX31H075	M48	75	67	30.505
LX31H080	M52	80	67	30.505
LX31H085	M56	85	73	30.505
LX31H090	M60	90	78	30.505
LX31H095	M64	95	78	30.505
LX31H100	M68	100	85	30.505
LX31H105	M72	105	85	30.505
LX31H110	M76	110	90	30.505
LX31H115	M80	115	90	30.505
LX31H120	M85	120	95	30.505
LX31H130	M90	130	100	30.505
LX31H135	M95	135	100	30.505

LX47				
No.	Saplama Ölçüsü	Anahtar Nut A/F	R1	Max. Tork
#	Bolt Size	mm	mm	N.m
LX47H080	M52	80	129	47.450
LX47H085	M56	85	129	47.450
LX47H090	M60	90	135	47.450
LX47H095	M64	95	135	47.450
LX47H100	M68	100	139	47.450
LX47H105	M72	105	139	47.450
LX47H110	M76	110	146	47.450
LX47H115	M80	115	146	47.450
LX47H120	M85	120	153	47.450
LX47H130	M90	130	160	47.450
LX47H135	M95	135	160	47.450
LX47H140	M95	140	163	47.450
LX47H145	M100	145	163	47.450
LX47H150	M105	150	169	47.450
LX47H155	M110	155	169	47.450