

**AIR SERVICE JACK****LARZEP advantages**

- From 30 to 80 Tn.
- Telescopic models with two and three stages.
- Operated by an air/hydraulic pump. Air pressure required: 8 to 12 bar.
- Ram return is automatic. Constant and controlled speed under load, can be increased without load.
- Check valves guarantee load holding, even if an air or oil pipe is accidentally broken.
- Equipped with an overpressure safety valve as protection against overloading.
- Three-position handle can be lowered to place the jack under the load.
- A hardened serrated load saddle and extension pieces of 70 and 120 mm are supplied as standard.
- Easy to operate, with the control located on the end of handle.



## AIR SERVICE JACKS

# HN

### 30-80 Tn.

### 8-12 bar

AUTOMOTIVE

### HN231

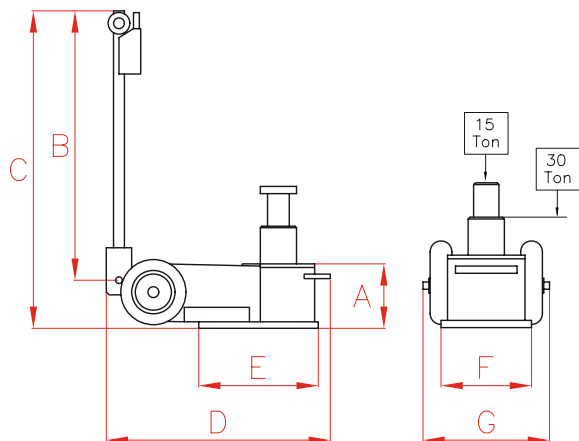

### HN360

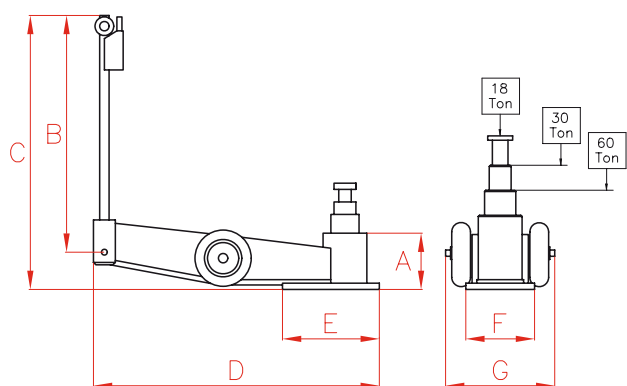

Extension pieces of 70 and 120 mm are supplied as standard.

### HN480

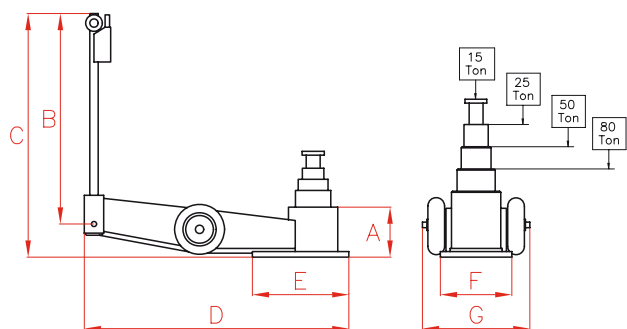

High Tonnage Air Service Jacks, HL.

Page. 156

Capacity	Stroke	Model	A	B	C	D	E	F	G	Weight
Tn	mm	LARZEP	mm	mm	mm	mm	mm	mm	mm	kg
15/30	88+83	<b>HN231</b>	150	1.315	1.400	525	270	206	300	39
18/30/60	91+72+74	<b>HN360</b>	180	1.310	1.395	980	320	240	350	70
15/25/50/80	66+56+68+60	<b>HN480</b>	180	1.310	1.395	980	320	240	350	78