

**HIGH TONNAGE AIR SERVICE JACK**



**LARZEP advantages**

- From 60 to 150 Tn.
- Models with one stage and telescopic with two and three stages.
- Operated by an air/hydraulic pump. Air pressure required: 8 to 12 bar.
- Air inlet port: 1/2" BSP.
- Dual descent valve for greater control.
- Fitted with self sealing pneumatic tyres for easy manoeuvrability.
- Special hooks for transport.
- Ram return is automatic. Constant and controlled speed under load, can be increased without load.
- Check valves guarantee load holding, even if an air or oil pipe is accidentally broken.
- Equipped with an overpressure safety valve as protection against overloading.
- Three-position handle can be lowered to place the jack under the load.
- Easy to operate, with the control located on the end of handle.
- Wide range of optional accessories: remote pendant, manual emergency pump, safety load blocks, safety block holder, safety blocks kit, extensions and extension holder.



Safety block



Holder

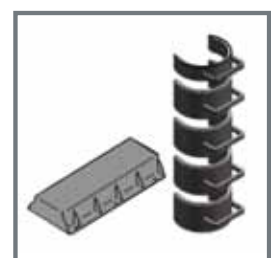

Kit

**HIGH TONNAGE AIR JACKS**

**HL**

**60-150 Tn.**

**8-12 bar**

AUTOMOTIVE

**HL08042**

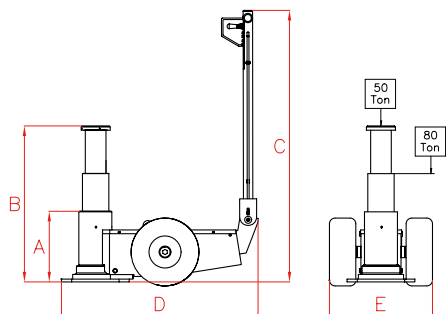

**HL08052**

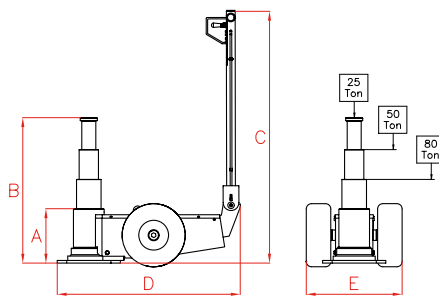

**HL06022**

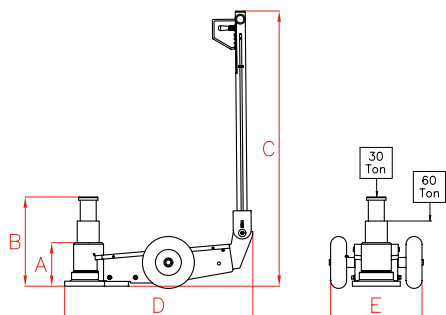

**HL10044**

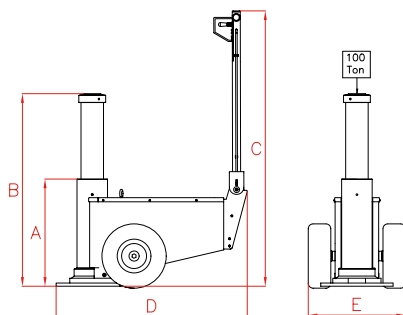

**HL15055**

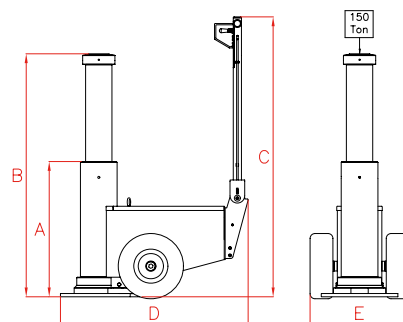

Capacity	Stroke	Model	A	B	C	D	E	Weight
Tn	mm	LARZEP	mm	mm	mm	mm	mm	kg
30/60	110+117	<b>HL06022</b>	220	447	1.385	940	460	93
50/80	196+222	<b>HL08042</b>	420	838	1.440	1.039	540	161
25/50/80	167+171+180	<b>HL08052</b>	341	859	1.440	1.040	540	143
100	445	<b>HL10044</b>	725	1.170	1.720	1.180	610	290
150	554	<b>HL15055</b>	900	1.454	1.720	1.250	620	385



Extensions



Extension Holder

**ACCESORIES (Optional)**

Model	Extension Holder		Extensions						
	Right	Left	10 mm	70 mm	120 mm	150 mm	200 mm	250 mm	300 mm
<b>HL06022</b>	-	-	HLE06001	HLE06007	HLE06012	-	-	-	-
<b>HL08042</b>	HLT080R	HLT080L	-	-	-	HLE08015	-	HLE08025	HLE08030
<b>HL08052</b>	HLT080R	HLT080L	-	-	-	HLE08015	-	HLE08025	HLE08030
<b>HL10044</b>	HLT150R	HLT150L	-	-	-	-	HLE15020	HLE15025	HLE15030
<b>HL15055</b>	HLT150R	HLT150L	-	-	-	-	HLE15020	HLE15025	HLE15030

Model	Safety Blocks				
	50mm M/F	100mm M/F	100mm F/F	Holder	Kit*
<b>HL06022</b>	-	-	-	-	-
<b>HL08042</b>	HLB05017M	HLB10017M	HLB10017F	HLC100	HLS100
<b>HL08052</b>	HLB05017M	HLB10017M	HLB10017F	HLC100	HLS100
<b>HL10044</b>	HLB05017M	HLB10017M	HLB10017F	HLC100	HLS100
<b>HL15055</b>	HLB05021M	HLB10021M	HLB10021F	HLC150	HLS150

Model	Remote Pendant	Manual Pump
<b>All models</b>	HLR	HLH



HLR



HLH

\*Safety blocks kit **HLS100**: HLB05017M + 3xHLB10017M + HLB10017F + HLC100  
 \*Safety blocks kit **HLS150**: HLB05021M + 4xHLB10021M + HLB10021F + HLC150