

Item	Desription	Item	Desription
1	Protective Frame	7	Electrical Control Box
2	Pressure Gauge	8	Cooler
3	Regulating Valve	9	Tank Plate
4	Valve Block	10	Check Valve
5	Oil Tank	11	Oil Filling Port
6	Oil Releasing Port	12	Oil Gauge

# Part List with drawing for Pump body

The drawing shows an exploded view of a pump body assembly. The parts are numbered 1 through 39. The assembly includes a top seal gasket (1), a screw (2), a bearing (3), a connect flange (4), a body sleeve (5), and a screw (6). The main body consists of a block for high pressure (7) with a pipe (8) and pipe fitting (9). It also features a connect fitting (10), a connector 2 (high pressure) (11), and screw 2 (12). The pump head (low pressure) (13) includes a checking valve (14) and a regulating valve (15). A relief valve (low pressure) (16) is also present, along with fittings (17, 18) and an O ring (19). The central shaft assembly includes a bearing (20), sleeve (21), and pump head (high pressure) (22). The bottom section features screw 3 (23), a fliter press (24), a retaining ring (25), piston 1 (26), high pressure piston (27), piston 2 (28), deep groove ball bearing 2 (29), another retaining ring (30), eccentric sleeve (31), copper sleeve (32), bearing outer ring (33), eccentric block (34), multi-tooth gasket (35), nut (36), screw 4 (37), screw 5 (38), and a filter cover (39).

Item	Name	QTY
1	Seal Gasket	1
2	Screw	4
3	Bearing	1
4	Connect Flange	1
5	Body Sleeve	1
6	Screw	8
7	Block for High Pressure	1
8	Pipe	1
9	Pipe Fitting	1
10	Connect Fitting	1
11	Connector 2(high pressure)	1
12	Screw 2	8
13	Pump head(low pressure)	1
14	Checking valve	1
15	Regulating valve	1
16	Relief valve(low pressure)	1
17	Fitting	1
18	Fitting	1
19	O ring	1
20	Bearing	1
21	Sleeve	1
22	Pump head(high pressure)	1
23	Screw 3	1
24	Fliter press	1
25	Retaining ring	1
26	piston 1	3
27	High pressure piston	2
28	Piston 2	1
29	Deep groove ball bearing 2	1
30	Retaining ring	1
31	Eccentric sleeve	1
32	Copper sleeve	1
33	Bearing outer ring	1
34	Eccentric block	1
35	Multi-tooth gasket	1
36	Nut	1
37	Screw 4	8
38	Screw 5	8
39	Filter cover	1

# Part List with drawing for Valve Block

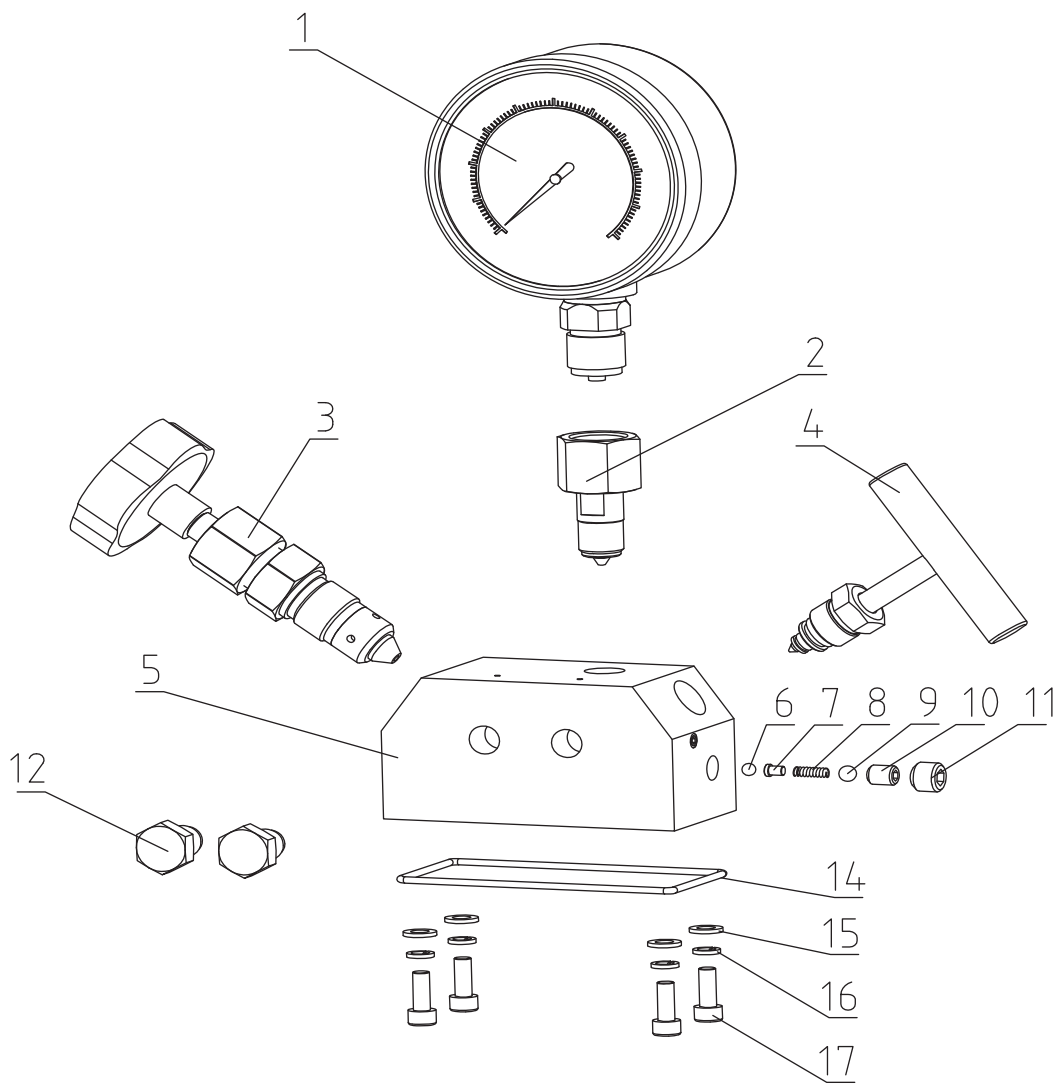

Item	Description	Quantity	Item	Description	Quantity
1	Gauge	1	10	Screw 1	1
2	Gauge adaptor	1	11	Screw 2	1
3	Regulating valve	1	12	Plug	2
4	Needle valve	1	13	O ring	1
5	Connector	1	14	Flat gasket	4
6	Steel ball 5	1	15	Spring gasket	4
7	Ejector pin	1	16	Screw	4
8	Spring	1			
9	Steel ball 6.35	1			