



Tork Anahtarları - Sistem 6000-1CT - [1 - 800 N.m]

Torque Wrenches - Series 6000-1CT - [1 - 800 N.m]



Sürücü/Drive: S10
Yön Mandallı Cırcır Sürücü
Reversible Ratchet Drive

- » Sıkma yönündeki hassasiyet $\pm 2\%$
- » **1 – 800 Nm** aralığında 11 farklı model
- » ISO 6789-2:2017 standardına uygun yapı
- » Sıkma ve sökmeye uygun yön mandallı cırcır
- » Sesli ve farkedilebilir tork erişim uyarı sistemi
- » Ergonomik tasarımlı tutma ve tork ayar kabzası
- » Ağır endüstri kullanımına elverişli tasarım
- » Kolay ayarlanabilir, seçilebilir lazer işlemeli skala
- » Hazet fabrika kalibrasyon belgesi ile sevk edilir
- » TÜRKAK akredite kalibrasyon hizmeti opsiyoneldir
- » Türkiye’de, servis yedek parça ve kalibrasyon desteği

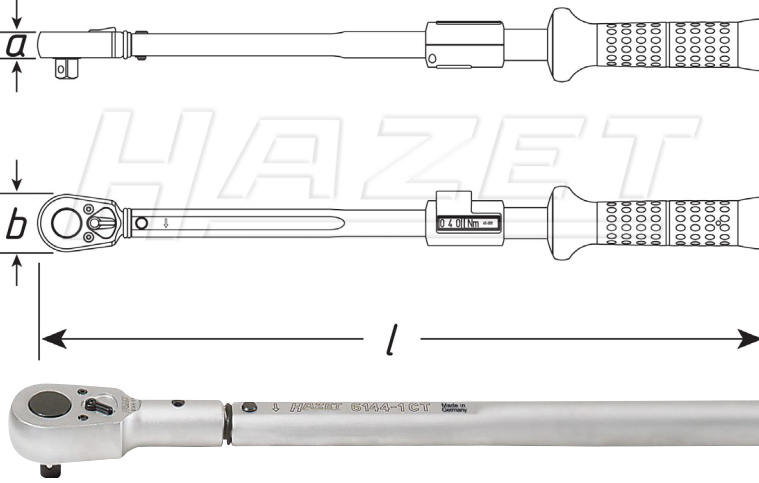

- » Accuracy $\pm 2\%$ of scale value
- » 1 - 800 Nm range covered by 11 models
- » Tested in accordance with ISO 6789-2:2017
- » Reversible ratchet and easy to read scale
- » Durable for tightening and loosening operations
- » Torque release palable and audible “click” sound
- » Designed for heavy duty industries application
- » Supplied with House calibration certificate
- » Delivered in protecting plastic safe box

Ayarlanabilir Yön Mandallı Cırcır Kare Sürüçülü Tork Anahtarları

Adjustable Reversible Ratchet Drive Torque Wrenches

Parça Part	Tork Aralığı Range	Sürücü Drive	Hassasiyet Accuracy	Cırcır Dişi Ratchet Teeth	Çalışma Açısı Opening Angle	Kuvvet* Force*	Ağırlık Weight	Uzunluk (mm) Length		
#	N.m	inch	%	#	°	kg	kg	a	b	l
6106-1CT	1-6	1/4" - S10	$\pm 4\%$	20	18	0.7-4.4	0.3	10.2	24	197
6108-1CT	2-10	1/4" - S10	$\pm 2\%$	20	18	1.4-7.3	0.3	10.2	24	198
6109-2CT	4-40	1/4" - S10	$\pm 2\%$	20	18	2.0-21.4	0.4	10.2	24	256
6110-1CT	5-60	3/8" - S10	$\pm 2\%$	30	12	1.9-24.7	0.6	14.5	32	335
6111-1CT	20-120	3/8" - S10	$\pm 2\%$	30	12	6.7-42.4	0.9	14.5	32	389
6121-1CT	20-120	1/2" - S10	$\pm 2\%$	32	11.25	6.0-37.4	1.2	19.6	44	435
6122-1CT	40-200	1/2" - S10	$\pm 2\%$	32	11.25	9.0-47.5	1.3	19.6	44	543
6123-1CT	60-320	1/2" - S10	$\pm 2\%$	32	11.25	10.8-59.6	1.5	19.6	44	659
6143-1CT	100-400	3/4" - S10	$\pm 2\%$	32	11.25	14.5-59.2	3.7	28.5	64	802
6144-1CT	200-500	3/4" - S10	$\pm 2\%$	32	11.25	21.6-54.6	5.5	28.5	64	1046
6145-1CT	300-800	3/4" - S10	$\pm 2\%$	32	11.25	25.9-70.2	6.3	28.5	64	1283

*Torkmetreyi kullanırken uygulanan maksimum ve minimum kuvveti temsil eder/ Actuating force minimum and maximum value

