



PNEUTORQUE[®]
PTM, PTME, TRUKTORQUE[™] SERIES
STALL TOOLS



CONTENTS

Part Numbers Covered By This Manual	2
Safety	3
Introduction	4
Parts Included	4
Accessories	5
Features and Functions	6
Set Up Instructions	7
Pneutorque® Hangar	7
Connecting Air Supply	7
Air Lubrication	8
Torque Reaction	8
Clockwise/Counter Clockwise Operation	11
Setting Torque to Tighten Fastener	11
Operating Instructions	12
Tightening	12
Releasing	13
Maintenance	14
Air Lubrication	14
Gearbox	14
Silencer	14
Drive Square	15
Calibration	15
Cleaning	15
Disposal	15
Specifications	16
Declaration of Conformity	18
Trouble Shooting	19
Glossary of Terms	19

PART NUMBERS COVERED BY THIS MANUAL

This manual covers the setup and use of Norbar Pneutorque® PTM, PTME, TrukTorque™ stall tools.

Part Number	Model	Direction	Maximum Torque
18100.F06	PTM-52-500-F	Forward (Clockwise) only	500 N·m
18100.B06	PTM-52-500-B	Bi-directional	
18101.F06	PTM-52-800-F	Forward (Clockwise) only	800 N·m
18101.B06	PTM-52-800-B	Bi-directional	
18102.F06	PTM-72-1000-F	Forward (Clockwise) only	1000 N·m
18102.B06	PTM-72-100-B	Bi-directional	
18162.B06	TrukTorque™	Bi-directional	1000 N·m
18162.B08	TrukTorque™	Bi-directional	
18103.F08	PTM-72-1350-F	Forward (Clockwise) only	1350 N·m
18103.B08	PTM-72-1350-B	Bi-directional	
18163.B08	TrukTorque™	Bi-directional	1350 N·m
18104.F08	PTM-72-2000-F	Forward (Clockwise) only	2000 N·m
18104.B08	PTM-72-2000-B	Bi-directional	
18106.F08	PTM-92-2700-F	Forward (Clockwise) only	2700 N·m
18106.B06	PTM-92-2700-B	Bi-directional	
18119.F08	PTM-92-4000-F	Forward (Clockwise) only	4000 N·m
18119.B08	PTM-92-4000-B	Bi-directional	
18119.F12	PTM-92-4000-F	Forward (Clockwise) only	
18119.B12	PTM-92-4000-B	Bi-directional	
18108.F12	PTM-119-4500-F	Forward (Clockwise) only	4500 N·m
18108.B12	PTM-119-4500-B	Bi-directional	
18109.F12	PTM-119-6000-F	Forward (Clockwise) only	6000 N·m
18109.B12	PTM-119-6000-B	Bi-directional	
18140.F06	PTME-72-1000-F	Forward (Clockwise) only	1000 N·m
18140.B06	PTME-72-1000-B	Bi-directional	
18141.F08	PTME-72-2000-F	Forward (Clockwise) only	2000 N·m
18141.B08	PTME-72-2000-B	Bi-directional	

NOTE: The main PTM, PTME TrukTorque™ models are listed above. Other PTM, PTME and TrukTorque™ stall tools with minor variances are also covered.

Description of Options:

Part Number Option	Description
****.F**	Forward (Clockwise) only
****.B**	Bi-directional (Clockwise and Counter Clockwise)
****.*06	3/4" A/F drive square size
****.*08	1" A/F drive square drive
****.*12	1 1/2" A/F drive square drive

Model Option	Description
PTM-**-***-*	Pneutorque® Twin Motor
PTME-**-****-*	Pneutorque® Twin Motor fixed nose extension
PTM*-52-****-*	52mm diameter gear box
PTM*-72-****-*	72mm diameter gear box
PTM*-92-****-*	92mm diameter gear box
PTM*-119-****-*	119mm diameter gearbox
PTM*-**-1000-*	Maximum torque in N·m
PTM*-**-****-F	Forward (Clockwise) only
PTM*-**-****-B	Bi-directional (Clockwise and Counter Clockwise)

SAFETY

IMPORTANT: DO NOT OPERATE THE TOOL BEFORE READING THESE INSTRUCTIONS. FAILURE TO DO SO MAY RESULT IN PERSONAL INJURY OR DAMAGE TO THE TOOL.

This tool is intended for use with threaded fasteners.

The use of proper ear protectors is recommended.

Do not use these tools in potentially explosive atmosphere as they contain grease, which may cause an explosion hazard in the presence of pure oxygen. These tools also contain aluminium alloy components which may cause a hazard in certain explosive environments.

Unexpected tool movement due to reaction forces or breakage of drive square or reaction bar may cause injuries.

Isolate the tool from all energy sources before changing or adjusting the drive square or socket.



There is a risk of crushing between the reaction bar and work piece.

Keep hands away from reaction bar.

Keep hands away from tool output.

Keep loose clothing, hair, etc. from being caught in any rotating part of the tool.

These tools require a reaction bar. See section on Torque Reaction.

Ensure all hoses are correctly fitted before switching on the air supply. This avoids the risk of injury by whipping air hoses.

Unexpected direction of drive square movement can cause a hazardous situation.

Use only sockets and adaptors which are in good condition and are intended for use with power tools.

Pneutorque[®] Wrenches are non-impacting, torque controlled threaded fastener tightening tools and must always be operated with the following:-

- Clean dry air supply with a minimum flow of 19 litres/sec (40 CFM).
- Lubro Control Unit or similar Filter, Regulator and Lubricator Unit 1/2" Bore (12 mm).
- Impact or high quality sockets.
- Reaction bar.



INTRODUCTION

The Pneutorque® PTM, PTME & TrukTorque™ tools are air driven power tools designed for applying torque to threaded fasteners. There are models to cover torque capacities of 500 N·m to 2000 N·m. The tools use an external air pressure regulator (included in a Lubro Control Unit) to set the air pressure that controls the stall torque.

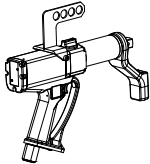
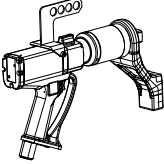
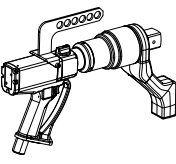
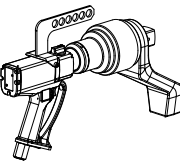
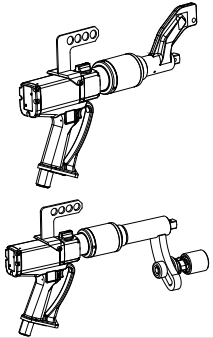
Parts Included

Description	Part Number				
	PTM-52	PTM-72	PTM-92	PTM-119	PTME-72 TrukTorque™
Visual Difference					
Pneutorque® Power Tool	18100.** 18101.**	18102.** 18103.** 18104.**	18106.** 18119.**	18108.** 18109.**	18140.** 18141.** 18162.** 18163.**
Cranked Reaction Bar	18646	18494	18936	18961	-
Reaction Bar Retaining Circlip	26588	26486	26486	26482	-
Hangar	18747	18747	18971	18971	18747
Operator's Manual (with air pressure graph & language CD [if required])	34321	34321	34321	34321	34321

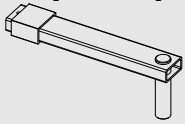
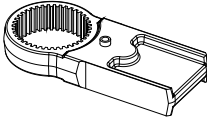
Accessories

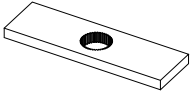
Description	Part Number					
	PTM-52	PTM-72	PTM-92	PTM-119	PTME-72	TrukTorque™
Air Coupling Socket for Hose	28933	28933	28933	28933	28933	28933
Lubro Control Unit	16074	16074	16074	16074	16074	16074
3/4" Drive Square (fixing screw)	18544 (25351.30)	18779 (25352.45)	-	-	-	-
1" Drive Square (fixing screw)	18545 (25351.30)	18492 (25352.45)	18934 (25352.60)	-	-	-
1 1/2" Drive Square (fixing screw)	-	-	18935 (25352.60)	18959 (25352.80)	-	-
3/4" Drive Shaft (fixing pin)	-	-	-	-	77112.2 (26287)	-
1" Drive Shaft (fixing pin)	-	-	-	-	18802 (26287)	-
Reaction Plate [NOTE 1] 	18298	18298	-	-	-	-
Reaction Adaptor [NOTE 1] 	18558	18290	-	-	-	-
Single-Sided Reaction Plate 	18576	18292	18979	16687	-	-
Double-Sided Reaction Plate 	18590	18293	18980	18981	-	-
Silencer	18591	18591	18591	18591	18591	18591
6" Blade Nose Extension	(3/4") 18594.006	(1") 18755.006	-	-	-	-
9" Blade Nose Extension	(3/4") 18594.009	(1") 18755.009	-	-	-	-
12" Blade Nose Extension	(3/4") 18594.012	(1") 18755.012	-	-	-	-
9" Nose Extension for Truck & Bus Wheels	-	(3/4") 19087.009 (1") 19089.009	-	-	-	-
12" Nose Extension for Truck & Bus Wheels	-	(3/4") 19087.012 (1") 19089.012	-	-	-	-

NOTE 1: Requires both the 'Reaction Bar' and 'Reaction Adaptor' to be used together.

FEATURES AND FUNCTIONS

Twin Motor

The tools use two motors; one to quickly run-down the fastener and the other to achieve final torque.

Trigger

The trigger controls the flow of air. The more the trigger is pressed the more air flows into the tool. This allows for slow positioning of socket and reaction bar. Once positioning is complete, the trigger must be fully pressed for correct torque application.

Clockwise/Counter-Clockwise Selector

Tools fitted with this option can be used for tightening counter-clockwise threaded fasteners and for releasing clockwise threaded fasteners.

Reaction Bar

The reaction bar ensures all reaction forces are contained, so that torque reaction is not passed back to the operator. Several reaction bar styles are available, including the PTME / Nose Extension reaction where tool access is restricted including applications on wheel nuts on heavy vehicles.

Non-Impacting

Low vibration levels make these tools comfortable and safe for the operator to use. In addition there is less damage to the tool, socket and threaded assembly.

Replaceable Drive Square

To avoid internal damage to the tool (especially due to torque overload), the output drive square has been designed to shear first. Pneutorque® tools are fitted with a drive square that can easily be replaced; alternative drive square sizes are also available.

Hanger

The hanger can be used to suspend the Pneutorque® from a balancer.

Quick Tool Coupling

Air couplings supplied to allow quick tool connection and disconnection from the air hose.

SET UP INSTRUCTIONS

The Pneutorque[®] set up covers the following items:

1. Pneutorque[®] Hanger
2. Connecting Air Supply
3. Air Lubrication
4. Torque Reaction
5. Clockwise / Counter Clockwise Operation
6. Setting torque to tighten fastener

Please complete the set up in the order shown.

Pneutorque[®] Hanger

The Pneutorque[®] hanger (Figure 1-E) is designed to be used with a suitable balancer to provide comfortable tool use. If not required the hanger can be removed.

Connecting Air Supply



WARNING: TO AVOID HAZARD FROM WHIPPING AIR HOSES MAKE ALL CONNECTIONS TO THE TOOL BEFORE TURNING ON THE AIR SUPPLY.

Make sure all hoses are clean, in good condition and free from dirt / water.

Connect the tool air inlet hose (Figure 1-A) to the outlet side of the lubro control unit (Figure 1-B) (not supplied), observing air flow direction arrows.

TIP: On tools supplied with quick air couplings, fit the coupling plug to the tool inlet and the coupling socket to air hose.

To connect, push couplings together.

To disconnect, pull back lock on socket coupling.



Connect the inlet side of the lubro control unit (Figure 1-B) to the air supply (Figure 1-C) using a minimum hose size of 1/2" bore (12mm). Avoid using 1/2" bore hoses of longer than 5 meters from the supply to the pressure regulator unit as this will reduce the performance of the tool.

Turn on air supply and check for air leaks.

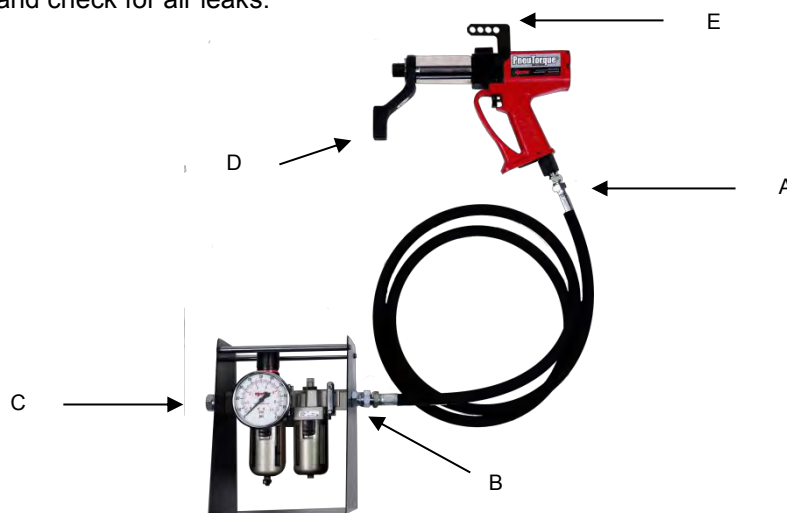

FIGURE 1 – Connections

Air Lubrication

The tool must be used with oil lubrication in the supplied air. This is achieved by using a Lubro Control Unit (not supplied).

Set the air lubrication:

- a. Fill Lubro Control Unit with hydraulic oil (Shell Tellus S2M 32 or equivalent good quality hydraulic oil).
- b. Ensure the tool drive is free to rotate.
- c. Run the tool by pressing the trigger.
- d. Adjust Lubro Control Unit to supply 6 drops of oil per minute.
- e. Release trigger.

See Lubro Control Unit Operator's Manual for more details.

Torque Reaction

The reaction bar ensures all reaction forces are contained, so torque reaction is not passed back to the operator. Several reaction bar styles are available.

Fit reaction bar as detailed below:

Tool Type	Reaction Bar Type	Fitting Instructions
PTM	Cranked reaction bar (standard)	Fit reaction bar / plate (Figure 1-D) over the drive square to engage reaction splines Secure with circlip supplied
	Single sided reaction plate (option)	
	Double sided reaction plate (option)	
	Nose Extension (option)	Fit as instructions supplied with nose extension 
PTME	Nose Extension (standard)	Factory fitted, not removable
TrukTorque™	Nose Extension (standard)	Factory fitted, not removable

It is essential the reaction bar rests squarely against a solid object or surface adjacent to the fastener to be tightened. The contact area must be within the shaded area of Figure 2, with the contact area as large as possible.

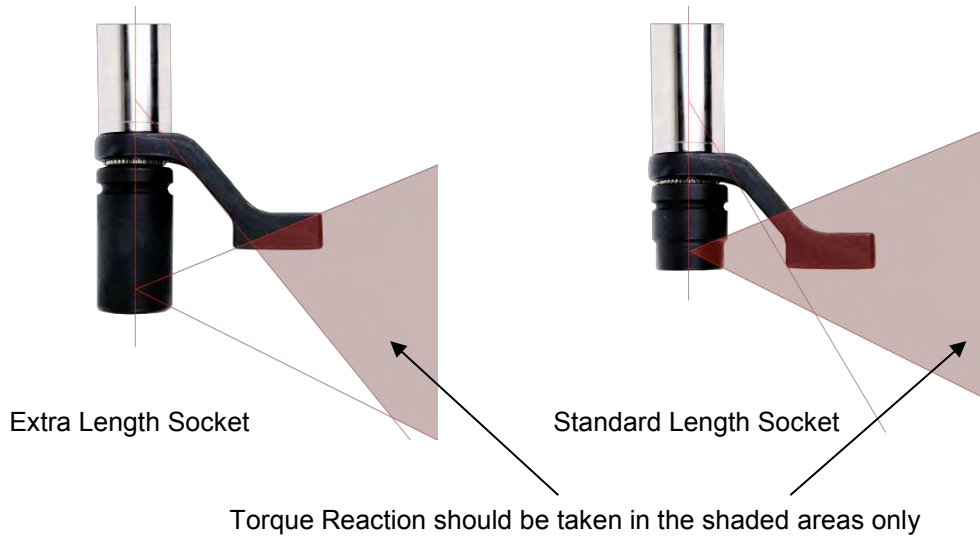

FIGURE 2 – Safe Reaction Window



WARNING: CARE MUST BE TAKEN TO ENSURE THAT THE REACTION BAR IS ONLY USED WITHIN THE LIMITATIONS SHOWN IN FIGURE 2.

For special applications or where extra deep sockets must be used the standard bar may be extended but only within the limitations shown on Figure 2. Alternative reaction bars are available, see page 5.



WARNING: FAILURE TO OBSERVE THE LIMITATIONS SHOWN IN FIGURE 2 WHEN MODIFYING STANDARD REACTION BARS MAY RESULT IN PREMATURE WEAR OR DAMAGE TO THE TOOL.

Standard drive square extensions MUST NOT be used as these will cause serious damage to the tool output drive. A range of nose extensions is available for applications where access is restricted. These are designed to support the final drive correctly.

The dimensions of the standard reaction bars is shown in the following table:

Reaction Bars (Standard)		Tool	'L'	'A'	'B'	'W'	'SQ'
		PTM-52	60	131	71	35	3/4"
		PTM-72	75	165	91	48	1"
		PTM-92	98.5	205	115	50	1" 1 1/2"
		PTM-119	127	199	65	55	1 1/2"
Reaction Bars (PTME)		Tool	'L'	'A'	'B'	'W'	'SQ'
		PTME-72 (1000 N·m)	80.5	110	63	12	3/4"
		PTME-72 (2000 N·m)	51.5	110	62	16	1"

Reaction Bars (TrukTorque™ & Nose Extension for Truck & Bus Wheels)	Tool	L	A	B	C	ØD	ØE	SQ
	TrukTorque™ 1000 N·m	98	47	132.5	29	52	38	3/4" 1"
	TrukTorque™ 1350 N·m	98	47	132.5	29	52	38	1"

When the Pneutorque® is in operation the reaction bar rotates in the opposite direction to the output drive square and must be allowed to rest squarely against a solid object or surface adjacent to the fastener to be tightened. (See Figure 3).

Pneutorque® Type	Torque Reaction	
	Clockwise	Counter-Clockwise (Bi-Directional Tools Only)
Example of PTM tool	<p>FIGURE 3(a)</p>	<p>FIGURE 3(b)</p>
Example of PTM tool with nose extension for truck & bus wheel option, PTME tool or TrukTorque™	<p>FIGURE 3(c)</p>	<p>FIGURE 3(d)</p>



WARNING: ALWAYS KEEP HANDS CLEAR OF THE REACTION BAR WHEN THE TOOL IS IN USE OR SERIOUS INJURY MAY RESULT.



Clockwise/Counter-Clockwise Operation

Set clockwise / counter-clockwise as required.

NOTE: This setting only applies to bi-directional tools.

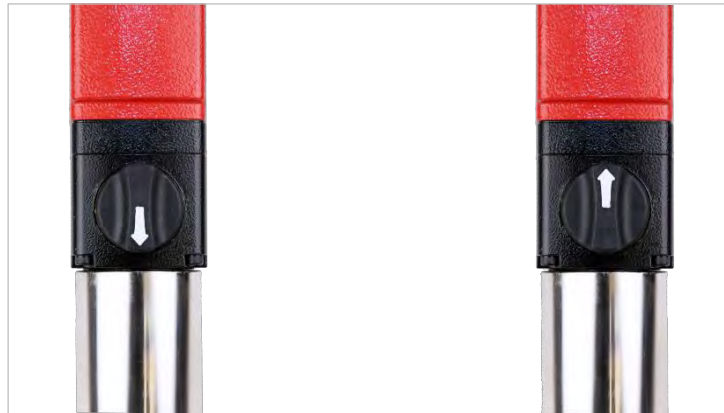

FIGURE 4(a) – Clockwise
(Arrow towards drive square)

FIGURE 4(b) – Counter - Clockwise
(Arrow away from drive square)



WARNING: FAILURE TO FULLY ENGAGE THE CLOCKWISE/COUNTER-CLOCKWISE OPERATION SELECTOR WILL RESULT IN DAMAGE TO THIS PART OF THE GEARBOX.

Setting Torque to Tighten Fastener

The torque created by the Pneutorque[®] depends on the air pressure setting. All tools are supplied with an Air Pressure Graph that gives the air pressure required to produce the correct torque output.

Set the torque output as follows:-

1. Use the Air Pressure Graph (supplied) to find the air pressure to achieve the required torque.
2. With the tool running, adjust the Lubro Control Unit until the correct air pressure is shown on the gauge.

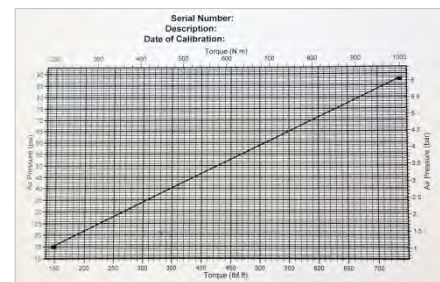

IMPORTANT: THE WRENCH MUST BE FREE RUNNING WHILE ADJUSTING THE AIR PRESSURE TO GIVE THE CORRECT SETTING.

IMPORTANT: CHECK THAT THE LUBRO CONTROL UNIT IS SUPPLYING APPROXIMATELY SIX DROPS OF OIL PER MINUTE WHILE THE TOOL IS FREE RUNNING.

OPERATING INSTRUCTIONS



WARNING: KEEP HANDS CLEAR OF THE REACTION BAR.



WARNING: WHEN USING THIS TOOL IT MUST BE SUPPORTED AT ALL TIMES IN ORDER TO PREVENT UNEXPECTED RELEASE IN THE EVENT OF FASTENER OR COMPONENT FAILURE.

Tightening

1. Fit Pneutorque[®] with the correct size impact or high quality socket to suit fastener.

TIP: For added safety it is recommended to secure the socket to the square drive. This is often achieved using a pin and O ring, see socket manufacturer for guidance.

2. Ensure the Clockwise/Counter-clockwise selector is correctly set (if fitted).
3. Rotate the handle into a convenient position relative to the reaction bar. Fit the tool onto the fastener to be tightened with the reaction bar adjacent to the reaction point. See Figure 5.
4. Adopt a suitable posture to counteract normal or unexpected movement of the tool due to reaction forces.
5. Squeeze the trigger partially to bring the reaction bar into contact with the reaction point.
6. Fully press trigger and keep fully pressed until tool stalls then release trigger. If the trigger is not fully pressed full torque will not be applied to the fastener.
7. Remove the tool from the fastener.



FIGURE 5

Releasing

NOTE: Only for bi-directional tools.

1. Fit the Pneutorque® with the correct size impact or high quality socket to suit the fastener to be released.

TIP: For added safety it is recommended to secure the socket to the square drive. This is often achieved using a pin and O ring, see socket manufacturer for guidance.

2. Ensure the clockwise/counter-clockwise selector is correctly set.
3. Rotate the handle into a convenient position relative to the reaction bar. Fit the tool onto the fastener to be released with the reaction bar adjacent to the reaction point. See Figure 6.
4. Adopt a suitable posture to counteract normal or unexpected movement of the tool due to reaction forces.
5. Squeeze the trigger partially to bring the reaction bar into contact with the reaction point.
6. Fully press trigger and keep fully pressed until threaded fastener releases.

TIP: If unable to release the fastener, increase the air pressure to the tool. Do not exceed the maximum air pressure for the tool.



WARNING: EXCEEDING THE MAXIMUM AIR PRESSURE WILL CAUSE OVERLOADING AND MAY LEAD TO SERIOUS DAMAGE.



WARNING: CHANGING THE AIR PRESSURE AFTER SETTING THE PRESSURE REGULATOR WILL CHANGE THE STALL TORQUE VALUE.



FIGURE 6

MAINTENANCE

For optimum performance and safety, regular tool maintenance is required. The user maintenance is limited to the replacement of the drive square and the silencer. Any other maintenance or repairs should be carried out by Norbar or a Norbar distributor. Maintenance intervals will depend on the tool usage and the environment in which it is being used. The maximum recommended maintenance and recalibration interval is 12 months.

TIP: Steps the user can take to reduce the amount of maintenance required include:

1. Use the tool in a clean environment.
2. Use an air compressor fitted with a dryer.
3. Ensure the Lubro Control Unit has sufficient hydraulic oil.
4. Ensure the Lubro Control Unit delivers hydraulic oil at the correct rate.
5. Ensure the Lubro Control Unit is regularly maintained, see product manual.
6. Maintain the correct torque reaction.

Air Lubrication

Add Shell Tellus S2M 32 or equivalent good quality hydraulic oil to the Lubro Control Unit.

Gearbox

Under normal operating conditions it is not necessary to re-grease the gearbox. The gearbox contains Lubcon Turmogrease Li 802 EP or equivalent good quality grease.

Silencer

The silencer (part number 18591) must be changed every 12 months. This may be more frequent for high tool usage or dirty environments.

TIP: Change silencer with tool upside down, as shown, to ensure internal parts (spring and valve) are kept in place.

1. Remove M4 screw (A) (part number 25381.10) using a 2.5mm hexagon key.
2. Remove pin (B) (part number 26284) using a pin punch.
3. Pull out air inlet tube (D) with base plate & silencer.
4. Remove silencer (E) from air inlet tube.
5. Fit new silencer (part number 18591) over air inlet tube.
6. Fit air inlet tube assembly (C, D & E) into handle against spring resistance.
7. Fit pin (B) with a hammer.
8. Fit screw (A) and torque to 0.5 N·m. Do not over tighten this screw as it is likely to break the base plate moulding.

TIP: When refitting air inlet tube assembly into handle care should be taken to ensure correct alignment between air inlet tube and spring. It may be easier to fit the spring into air inlet tube first and secure with a small amount of grease.

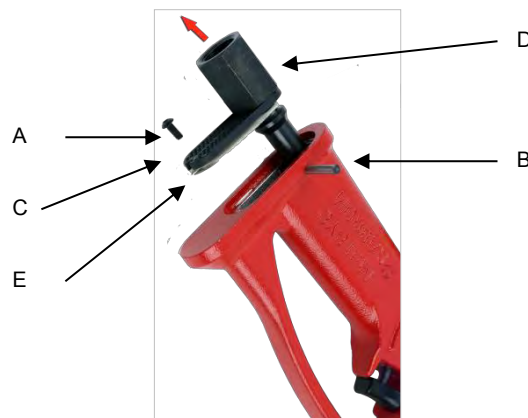

FIGURE 7 – Silencer Replacement

Drive Square

To avoid internal damage (especially due to torque overload), the output drive square has been designed to shear first. This saves major internal damage and allows easy square removal. For drive square part numbers see page 5.



FIGURE 8 – Square Drive Replacement

To replace drive square:

1. Remove the air supply.
2. Support tool in a horizontal position.
3. Remove the screw or spring pin, then remove drive square.
If the square has sheared it may be necessary to use pliers to remove the broken parts.
4. Fit new drive square.
5. Fit new screw and tighten between 4 N·m to 5 N·m (for PTM52) or 8 N·m to 9 N·m (for PTM72/92/119) or insert new spring pin.
6. Connect air supply.

TIP: If the drive square fails continually then seek advice from Norbar or a Norbar distributor.

Calibration

To maintain the Pneutorque® accuracy it is recommended the tool is recalibrated at least every 12 months. Contact Norbar or a Norbar distributor for more information.

Cleaning

Keep the tool in a clean condition to aid safety. Do not use abrasives or solvent based cleaners.

Disposal

Recycling Considerations:

Component	Material
Handle	Aluminium Case / Steel Internals
Gearbox (Clockwise / Counter-Clockwise)	Aluminium Case / Steel Internals
Gearbox (52mm / 72mm / 92mm / 119mm)	Steel with Nickel Plated Case / Steel Internals
Reaction Bar	PTM-52 is Steel / PTM-72 is Aluminium

SPECIFICATIONS

Part Number	Torque		Tool Speed
	Minimum	Maximum	
18100.**	100 N·m (74 lbf·ft)	500 N·m (370 lbf·ft)	224 rev/min
18101.**	160 N·m (118 lbf·ft)	800 N·m (590 lbf·ft)	148 rev/min
18102.** / 18140.** / 18162.**	200 N·m (147 lbf·ft)	1000 N·m (738 lbf·ft)	122 rev/min
18103.** / 18163.**	270 N·m (200 lbf·ft)	1350 N·m (1000 lbf·ft)	86 rev/min
18104.** / 18141.**	400 N·m (295 lbf·ft)	2000 N·m (1475 lbf·ft)	58 rev/min
18106.**	540 N·m (400 lbf·ft)	2700 N·m (2000 lbf·ft)	46 rev/min
18119.**	800 N·m (590 lbf·ft)	4000 N·m (2950 lbf·ft)	32 rev/min
18108.**	900 N·m (660 lbf·ft)	4500 N·m (3300 lbf·ft)	23 rev/min
18109.**	1200 N·m (885 lbf·ft)	6000 N·m (4425 lbf·ft)	15.5 rev/min

Part Number	Dimensions (mm)					Tool Weight (kg)		Reaction Weight (kg)
	H	W	R	L		****.F**	****.B**	
				****.F**	****.B**			
18100.**	318	82	60	284	333	3.8	4.1	0.85
18101.**	318	82	60	284	333	3.8	4.1	0.85
18102.**	318	85.7	75	316	365	5.8	6.1	0.7
18103.**	318	85.7	75	316	365	5.8	6.1	0.7
18104.**	318	85.7	75	349	398	6.2	6.5	0.7
18106.**	318	92	98.5	375	424	8.2	8.5	1.35
18119.**	318	92	98.5	375	424	8.2	8.5	1.35
18108.**	318	119	127	407	456	13	13.3	2.1
18109.**	318	119	127	407	456	13	13.3	2.1
18140.**	318	82	51.5	435	484	6.9	7.2	-
18141.**	318	82	51.5	457	506	7.4	7.7	-
18162.**	318	82	82	-	532	-	9.4	-
18163.**	318	82	82	-	532	-	9.5	-

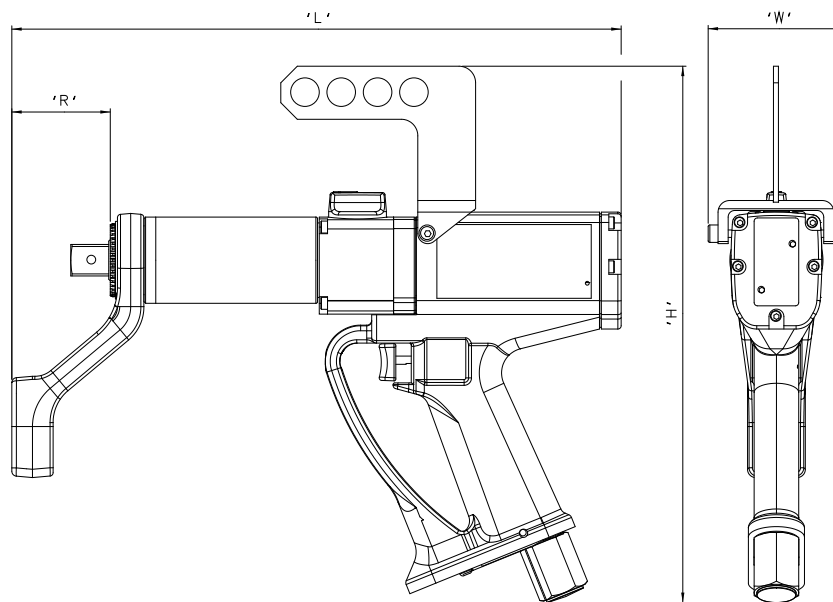

FIGURE 9 – Tool Dimensions

Repeatability:	± 5%
Air Supply:	Maximum pressure 6.3 bar (For maximum output speed).
Lubrication:	Shell Tellus S2M 32 recommended for the Lubro Control Unit.
Temperature Range:	0°C to +50°C (operating). -20°C to +60°C (storage).
Operating Humidity:	85% Relative Humidity @30°C maximum.
Handle Vibration:	< 2.5 m/s ² Maximum. Tested in accordance with ISO 8662-7 Hand held portable tools. Measurement of vibrations at the handle.
Sound Pressure Level:	84 dBA measured at 1m equivalent continuous A weighted sound. Tested to BS ISO 3744: 1994 Acoustics. Determination of sound power levels of noise sources using sound pressure. Engineering method in an essentially free field over a reflecting plane. Test conducted in free running condition with a supply pressure of 6.3 bar.
Environment:	Store in a clean & dry environment.
Machinery Directive:	In conformance with: BSEN 792-6:2000 Hand-held non-electric power tools. Safety requirements. Assembly power tools for threaded fasteners.

Due to continuous improvement all specifications are subject to change without prior notice.

NOTE: If equipment is used in a manner not specified by the manufacturer, the protection provided by the equipment could be impaired.



Norbar Torque Tools Ltd
 Beaumont Road
 Banbury
 Oxfordshire
 OX16 1XJ
 United Kingdom

Tel: + 44 (0) 1295 270333
 Fax: + 44 (0) 1295 753643
 E-mail: enquiry@norbar.com

Registered in England No.380480
 VAT No. GB 119 1060 05

QA57
 ISSUE 2
 24.1.97

Declaration of Conformity

Manufactured by Norbar Torque Tools Ltd.,
 Beaumont Road, Banbury, Oxon, OX16 1XJ

The Directives covered by this Declaration

Safety of Machinery Directive, 2006/42/EC.

The Equipment Covered by this Declaration

Equipment: Pneutorque® PTM, PTME & TrukTorque™ Series Stall Tools.

Model Name(s): PTM-52-****_*
 PTM-72-****_*
 PTM-92-****_*
 PTM-119-****_*
 PTME-52-****_*
 PTME-72-****_*
 TrukTorque™

The Basis on which Conformity is being Declared

The equipment identified above is in compliance with the protection requirements of the above directive, and the following standards have been applied:-

EN 792-6:2000 Hand-held non-electric power tools – Safety requirements.
 Pt 6: Assembly power tools for threaded fasteners.

The technical documentation required to demonstrate that the products meet the requirements of the above Directives has been compiled by the signatory below and is available for inspection by the relevant enforcement authorities. The CE mark was first applied in: 2007.

Signed: *T. M. Lester* **Full Name:** Trevor Mark Lester B.Eng.
Date: 19th October 2010 **Authority:** Compliance Engineer

www.norbar.com

United Kingdom • Australia • United States of America • New Zealand • Singapore • China

TROUBLE SHOOTING

The following is only a guide, for more complex faults please contact Norbar or a Norbar distributor.

Problem	Likely Solutions
Tool output does not rotate when trigger pressed	<ul style="list-style-type: none"> Check air supply is functioning and connected Check air pressure setting (at least 1 bar) Check correct setting of direction knob Output drive square sheared, needs replacing Gear train or air motor is damaged
Drive square is sheared	See maintenance section to replace drive square
Tool does not stall	<ul style="list-style-type: none"> Fastener sheared or thread stripped Gear train or air motor is damaged

GLOSSARY OF TERMS

Word or Term	Meaning
A/F	Across Flats
Air pressure Graph	Graph supplied with all stall tools to show the air pressure setting to produce required torque
Bi-directional	Tool capable of Clockwise and Counter-clockwise square rotation
Calibration Device	Torque measurement system to display peak torque using a joint simulator or test fastener
Fastener	Bolt or stud to be tightened
Lubro Control Unit	Unit to provide filtering and lubrication along with pressure regulation. Not supplied with tool
Nose Extension	A reaction type used where tool access is restricted, typical examples on wheel nuts on heavy vehicles. Available as an option for PTM tools or integral for PTME tools
Pneutorque®	Product name
PTM	Pneutorque® Twin Motor
PTME	Pneutorque® Twin Motor with fixed nose extension
Reaction Bar	Item to counteract applied torque. Also called reaction plate
Stall Tool	Tool will stall due to air pressure set.
TrukTorque™	Pneutorque® Twin Motor with fixed nose extension, designed for truck and bus wheel nuts

NOTES

**NORBAR TORQUE TOOLS LTD**

Beaumont Road, Banbury,
Oxfordshire, OX16 1XJ
UNITED KINGDOM
Tel + 44 (0)1295 270333
Email enquiry@norbar.com

**NORBAR TORQUE TOOLS PTE LTD**

194 Pandan Loop
#07-20 Pantech Business Hub
SINGAPORE 128383
Tel + 65 6841 1371
Email singapore@norbar.com.au

**NORBAR TORQUE TOOLS PTY LTD**

45–47 Raglan Avenue, Edwardstown,
SA 5039
AUSTRALIA
Tel + 61 (0)8 8292 9777
Email enquiry@norbar.com.au

**NORBAR TORQUE TOOLS (SHANGHAI) LTD**

E Building–5F, no. 1618 Yishan Road,
Minhang District, Shanghai
CHINA 201103
Tel + 86 21 6145 0368
Email sales@norbar.com.cn

**NORBAR TORQUE TOOLS INC**

36400 Biltmore Place, Willoughby,
Ohio, 44094
USA
Tel + 1 866 667 2279
Email inquiry@norbar.us

**NORBAR TORQUE TOOLS INDIA PVT. LTD**

Plot No A-168, Khairne Industrial Area,
Thane Belapur Road, Mahape,
Navi Mumbai – 400 709
INDIA
Tel + 91 22 2778 8480
Email enquiry@norbar.in

**NORBAR TORQUE TOOLS (NZ) LTD**

B3/269A Mt Smart Road
Onehunga, Auckland 1061
NEW ZEALAND
Tel + 64 9579 8653
Email nz@norbar.com.au

www.norbar.com