

- 1) Push clamp arm (5) of suspension strut inside or outside but only with opened guard grille (7).
- 2) Put in suspension strut into lower clamp claw (10) suspension strut should always rest on lower clamp (10). Clamp claws are adjustable 'till suspension strut is upright! (vertical)
- 3) Adjust upper clamp arms (5) to suspension strut by turning the spindle (4). Upper clamp claws have to rest perfectly on suspension strut disc.
- 4) Check the upright (vertical) position of suspension strut after having clamped slightly by hand with spindle.
- 5) Close guard grille (7) lock it with guard grille screw (6).

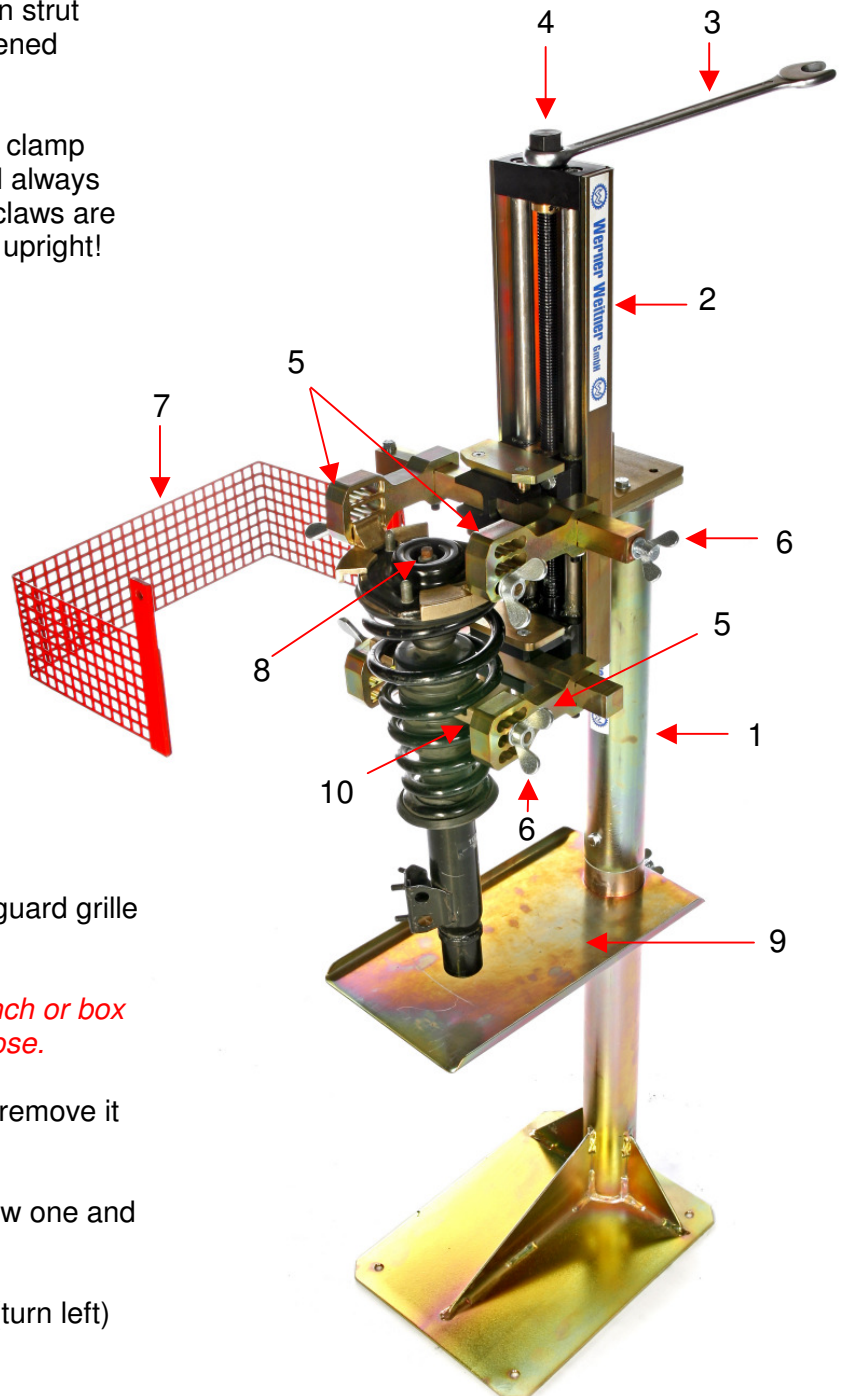

*Clamp suspension strut with torque wrench or box wrench (3). 'till shock absorber hangs loose.*

- 6) Release shock absorber nut and remove it downwards.
- 7) Change shock absorber put in new one and clamp it.
- 8) Release suspension strut clamp (turn left)

Reference:

**Do not use wrench hammer!**

Suspension Strut can be clamped in 3 different positions:

**Pos. I**

Suspension strut only clamped in spring.  
First release hexagonal nut and socket head cap screw.

**Pos. II**

Suspension strut clamped by spring rest.  
First release hexagonal nut and socket head cap screw.

**Pos. III**

Suspension strut clamped by suspension strut bearing. Even if suspension strut is not completely upright inserted, it will cause no problems. Suspension strut goes automatically in upright position. For clamping use only ring spanner wrench never wrench hammer!

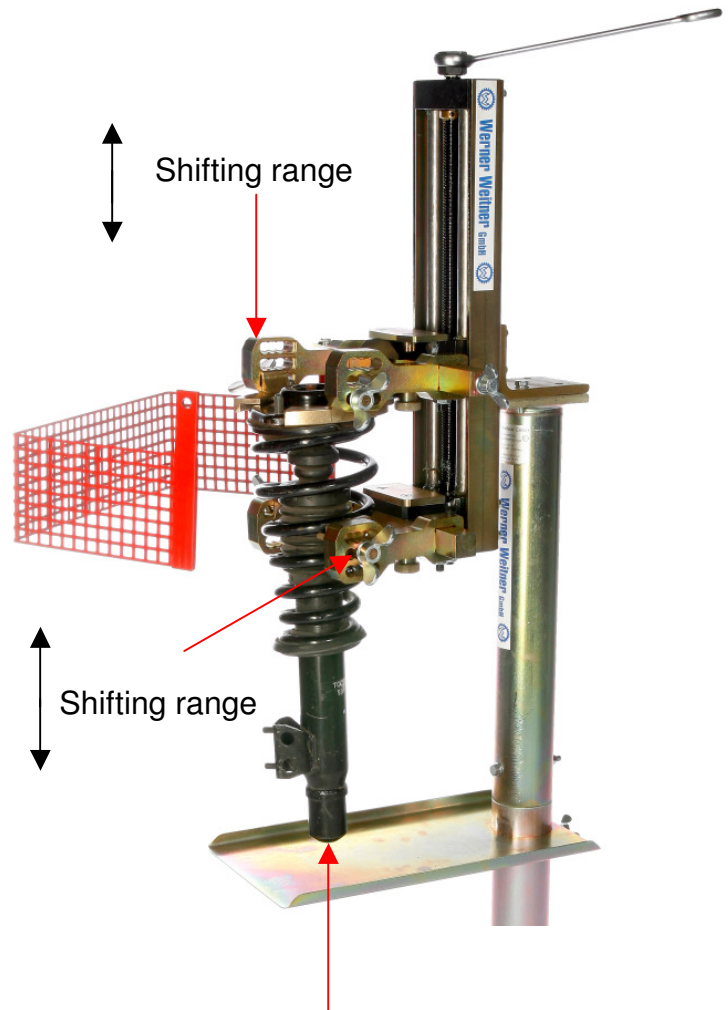

Suspension strut

**Technical dates:**

Breadth	500 mm
Height	1400 mm
Max. Diameter of Spring	220 mm
Max. Spring Tension	8.3 kN
Max. Torque of Spindle	24.4 Nm
Weight	38 kg