

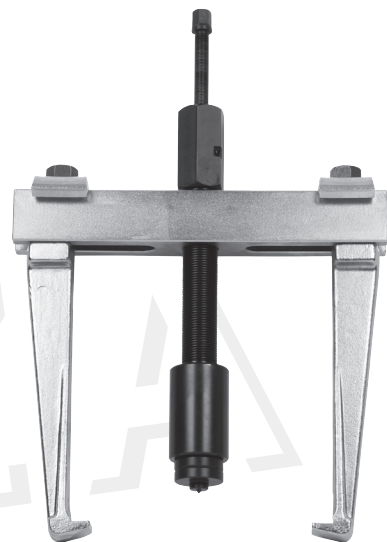

15TM COMPACT SPINDLE PULLERS

Manual
User's manual



1016H

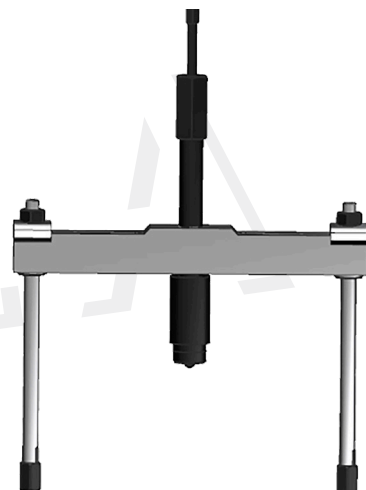

1116H



1316TH

INDICE

1. 16Tm spindle
2. 1016H pullers 2 jaws
3. 1116H pullers 2 extenders
4. 2400H 2 jaws
5. 1200 series combinations
6. 3 jaws pullers 1315TH/ATH
7. User instructions

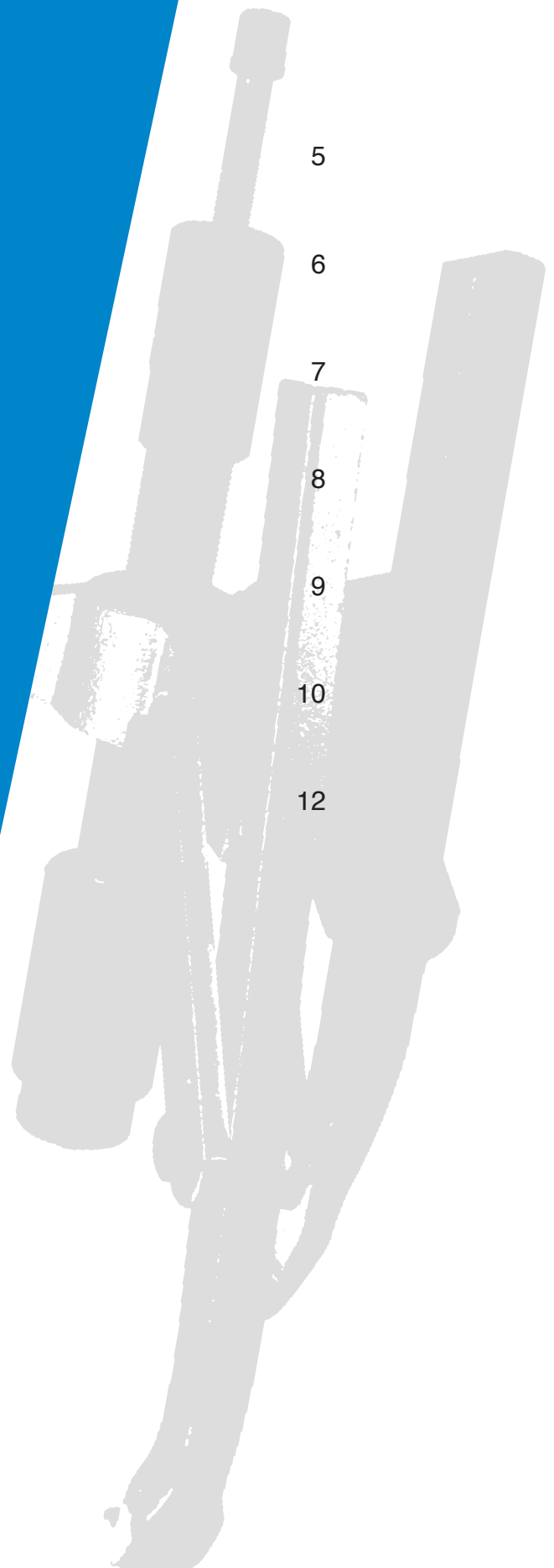

5

6

7

8

9

10

12

■ 1. 16TON. SPINDLE



16 Ton spindle.

The subspindle shall be tighten with a spanner of 17.
By using this spanner 15 ton are easily reached.
Never use neither pipes nor levers to apply more force.

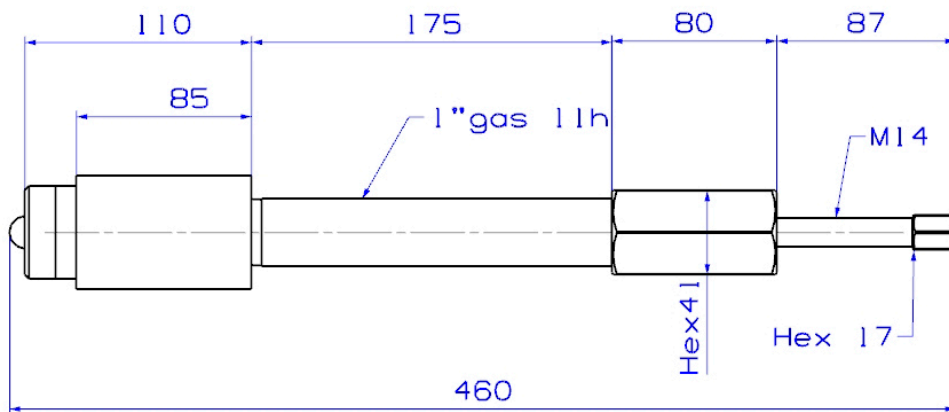

Ref: 101683

■ 2. 1016H PULLER.

Technical features

- 2 jaws puller
- External
- Fixed jaws
- Forged jaws

2.1. Pullers dimensions

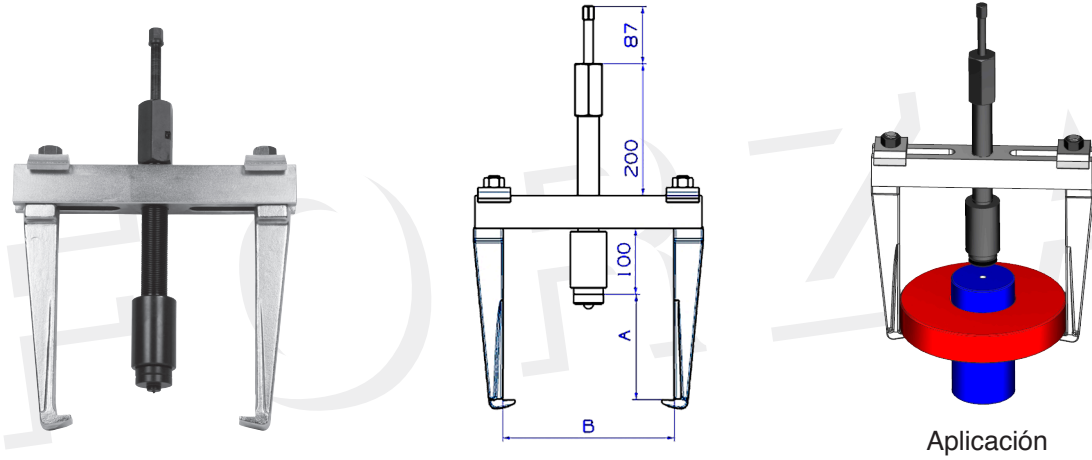

Reference	A	B	C	F	Ton.	Weigth	Jaw
1016H	160	250	345	101683	16	12,5	102050
1016LH	290	250	345	101683	16	15,5	102060
1016AH	160	390	475	101683	16	15,0	102050
1016LAH	290	390	475	101683	16	17,0	102060
1016XH	160	600	675	101683	16	22,0	102050
1016XAH	290	600	675	101683	16	25,0	102060

2.2. Exploded view

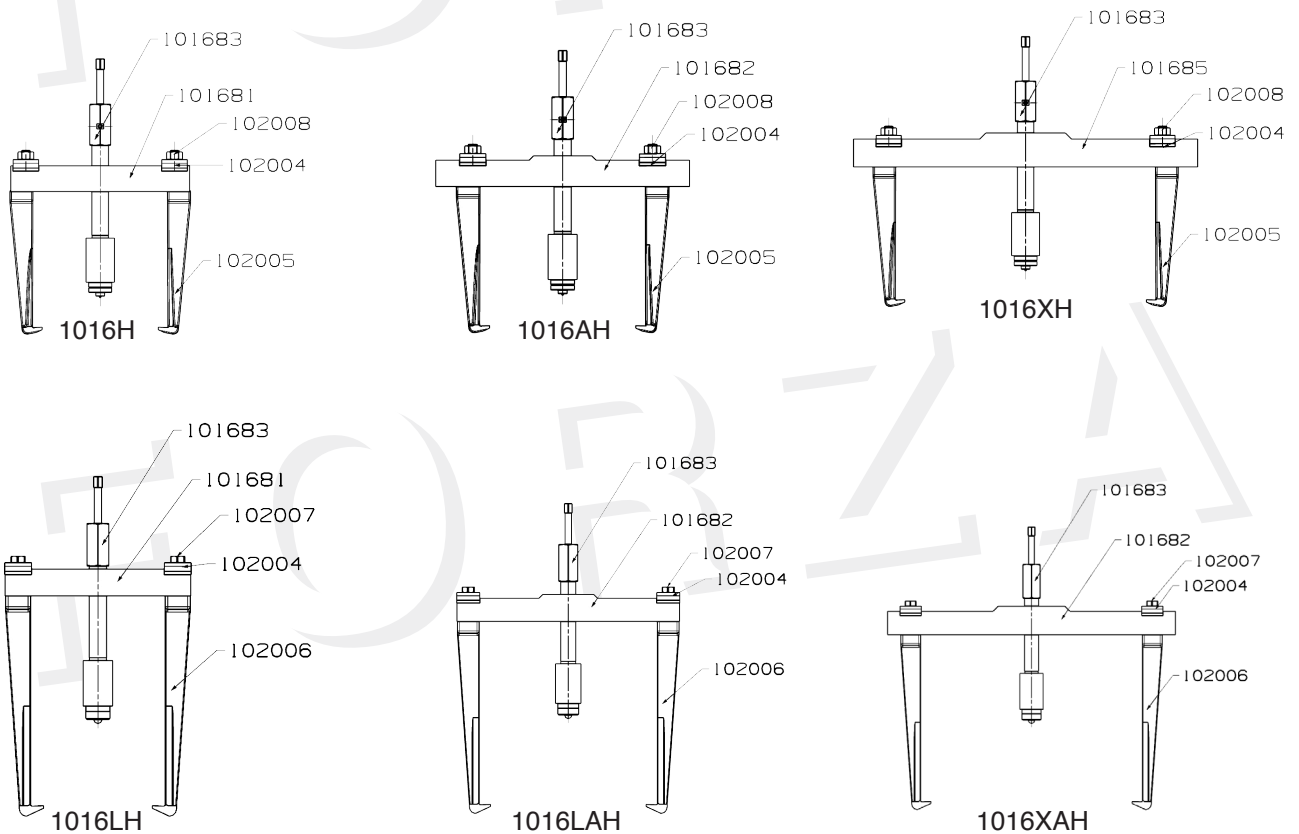

3. 1116H PULLER

Technical features.

- 2 extenders puller
- It combines with 1206B and 1208B splitters.

3.1 Dimensiones del extractor

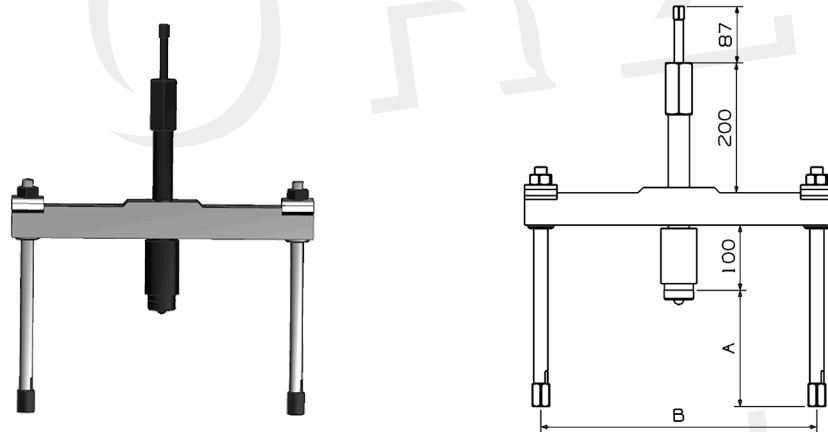

Reference	A	Bmax	Bmin	Weigth
1116H	155	325	105	11,3
1116AH	155	445	173	13,8

3.2. Exploded view

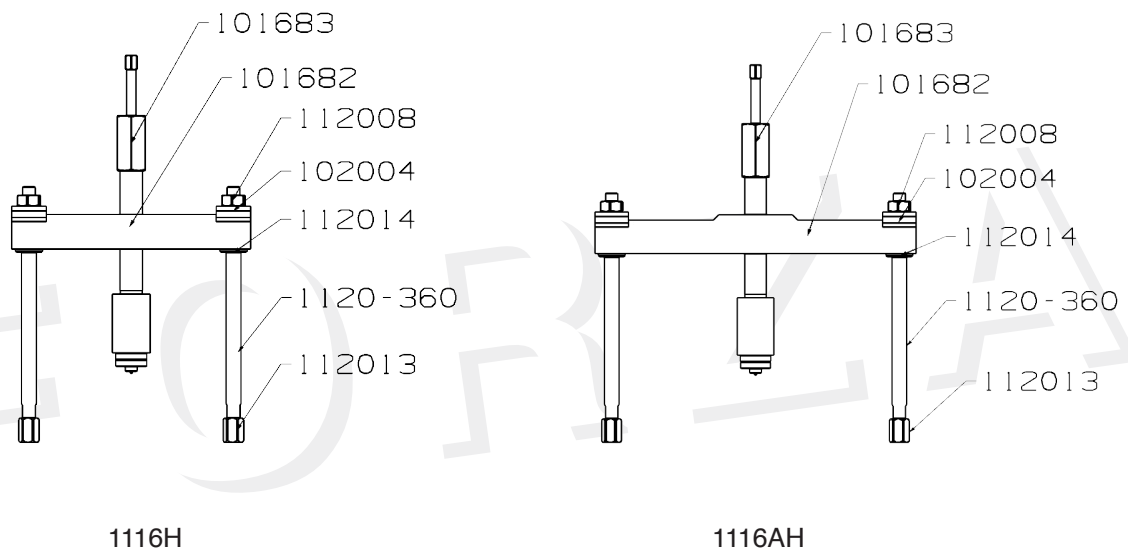

4. 2400H PULLER.

Technical features.

- 2 jaws puller.
- External
- It can stand 16 ton.
- Fixed jaws

4.1 Puller dimensions

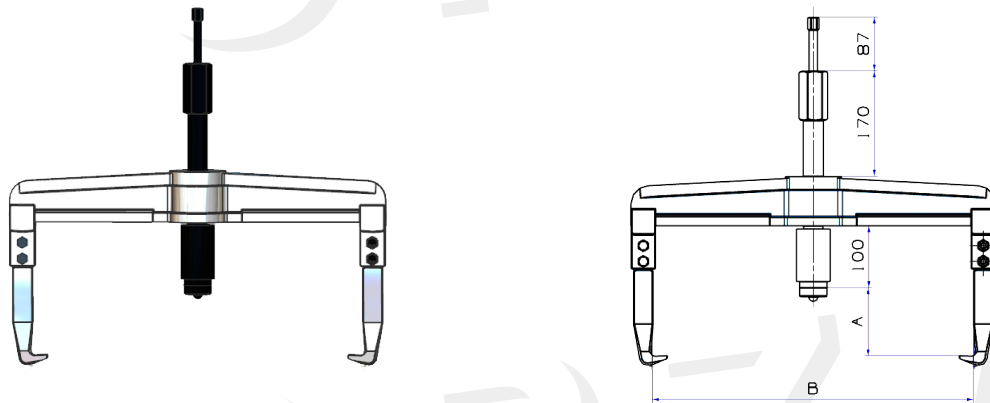

Reference	A	B	C	Weigth
2430H	100	240	325	9,5
2430LH	280	240	325	11,0
2435H	100	350	425	11,0
2435LH	280	350	425	12,0
2440H	100	510	585	17,0
2440LH	280	510	585	18,0
2450H	125	640	717	25,0
2450LH	250	640	717	28,0

4.2. Exploded view

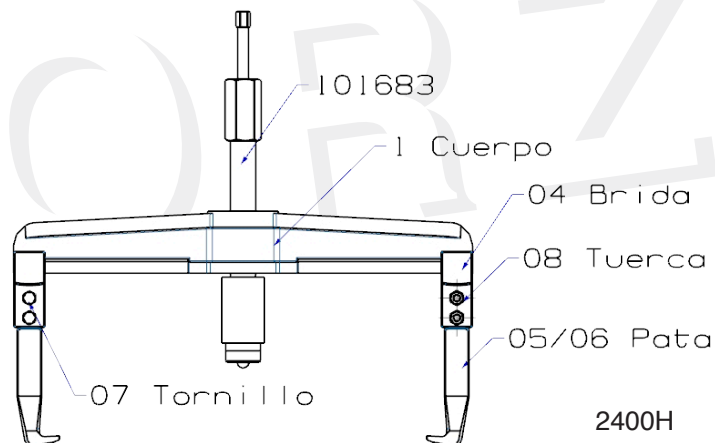

5. COMBINATIONS WITH 1200 SPLITTERS.

1116H pullers combine with 1200 series:

As a measure of the pulley to be extracted, Do not take the splitter minimum dimension B, but the height C, which is the distance between the extenders.

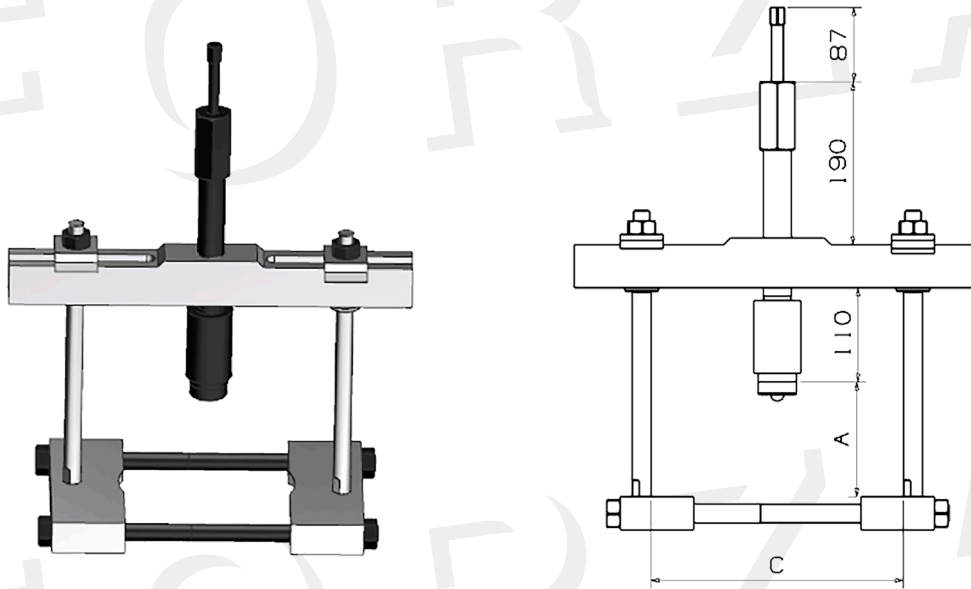

Reference	A	C
1116H - 1206B	110	182
1116AH - 1208B	110	306

Correct assembly of splitters.

The 1200 puller must be supported on the flat side.

The extenders shall be as close as possible to the part to be extracted.

That is to say, the distance L is as small as possible.

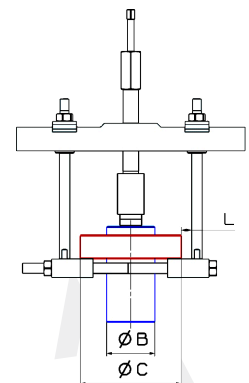

Incorrect assembly of splitters.

The 1200 puller is not supported on the flat side.

The extenders are very far from the part to be extracted. That is to say, the distance L is very large.

In this position the torque on the extender tip is multiplied by L.

In this position the maximum tension CAN NOT be reached. Watch the deflection of the splitter spindles and stop when you see it too big.

In this position the maximum tension CAN NOT be reached. Watch the deflection of the splitter spindles and stop when you see it too big.

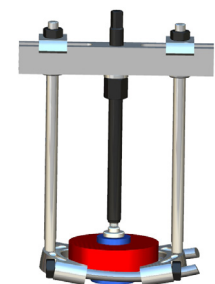

6.3 JAWS PULLER

Technical features

- 2 and 3 forged jaws
- External
- Forged jaws

6.1 1315TH PULLER

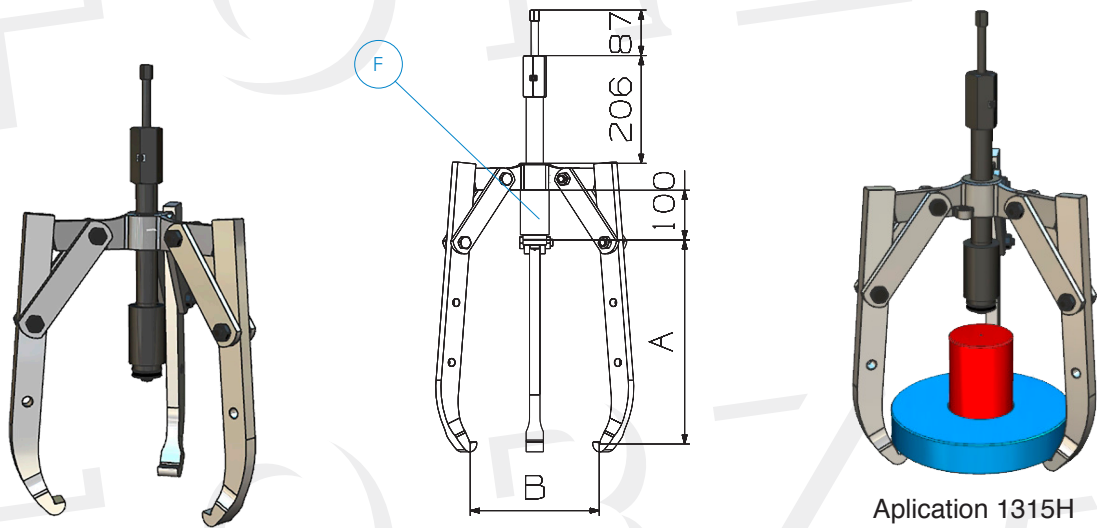

Reference	A	B	Ton.	Weigth	Jaw
1315TH	265	425	16	20	131705
1315LTH	380	480	16	23	131706
1315XTH	500	540	16	26	131716

6.1.1 Exploded view

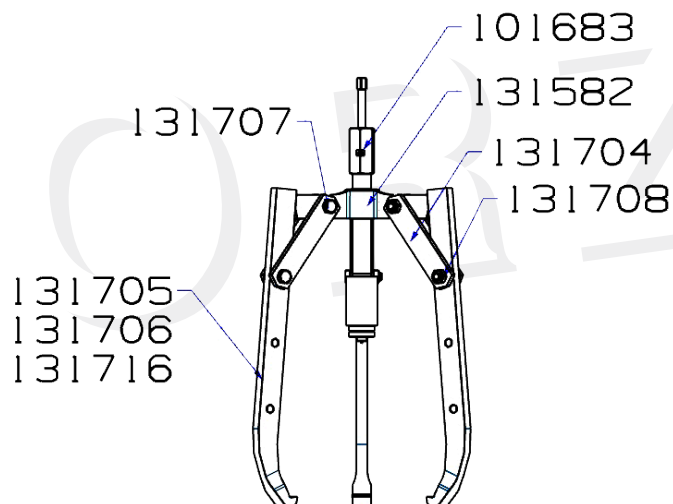

6.2 1315THA PULLER (Self-centering)

All the jaws move simultaneously. The selfcentering puller is very safe because it cannot be opened more than its suitable use allows.

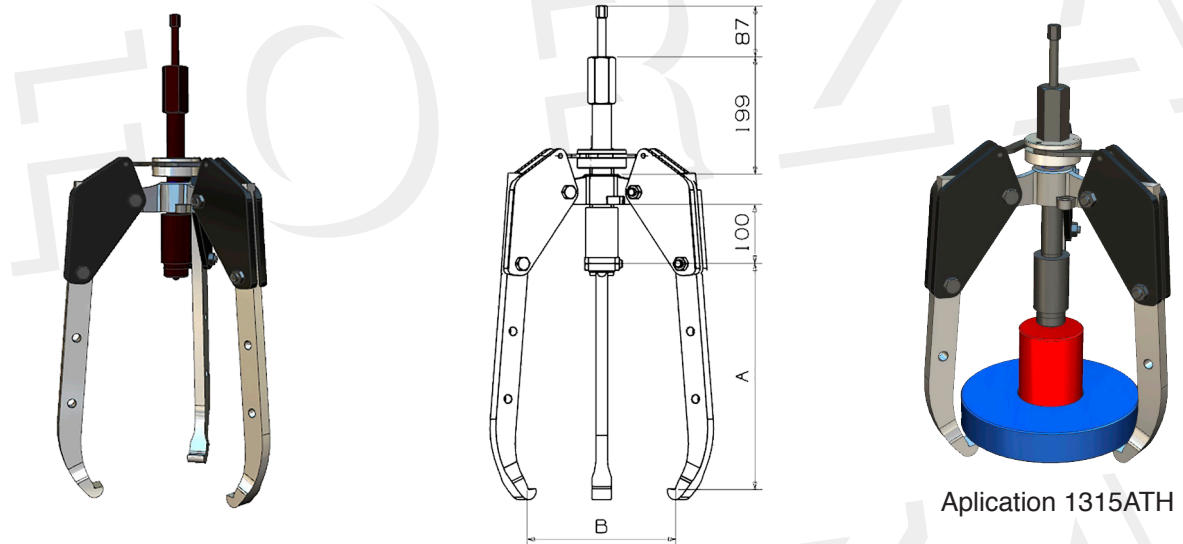

Reference	A	B	Ton.	Weigth	Jaw
1315ATH	265	425	16	29	131705
1315ALTH	385	480	16	32	131706
1315AXTH	500	540	16	35	131716

6.2.1 Exploded view

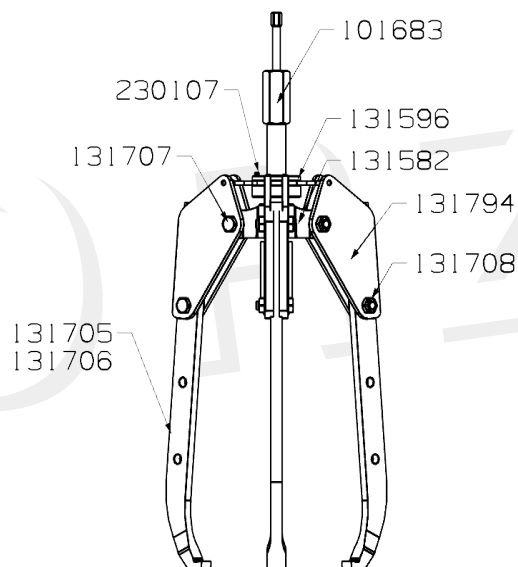

7. USER INSTRUCTIONS



- 1-Make sure that the extender or the jaws are well centered.
- 2- Use all the necessary personal protective equipment (PPE).
- 3- The force is made by the hydraulic spindle.

Instructions for use of the 1016H pullers



Release the M-8 prisoner with a key



Unscrew the spindle head

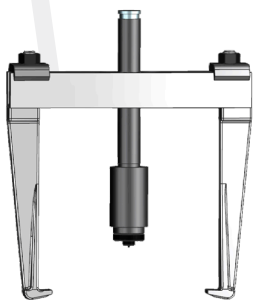

Thread the spindle to the body

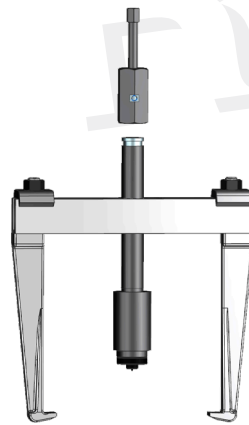

Thread the head to the spindle

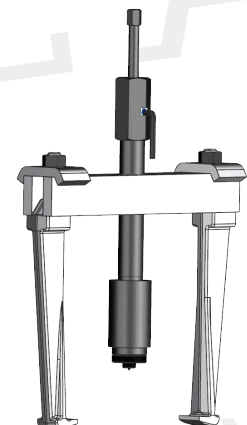

Tighten the M-8 prisoner

Instructions for use of 1116H pullers



Release the M-8 prisoner with a key



Unscrew the spindle head

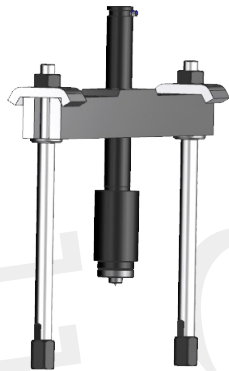

Thread the spindle to the body

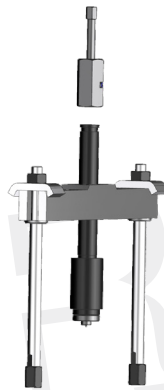

Thread the head to the spindle

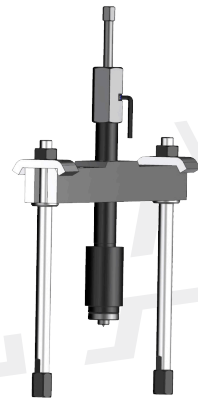

Tighten the M-8 screw

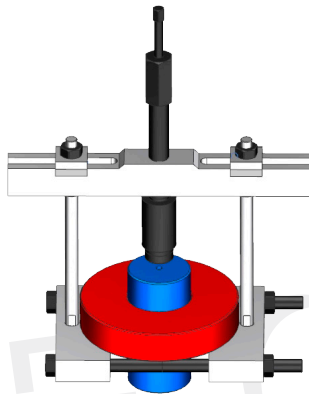

The extenders should be as close as possible to the pulley, the L dimension should be as small as possible. Let the pulley touch the extenders. This will prevent the splitter spindle from bending.

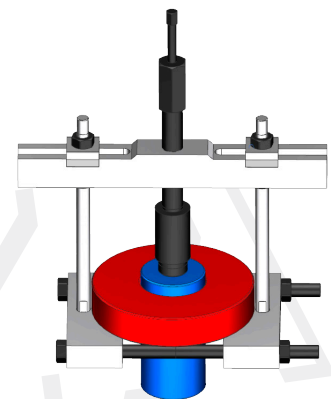

Instructions for use of 1316TH / THA pullers



Release the M-8 screw with a key



Unscrew the spindle head

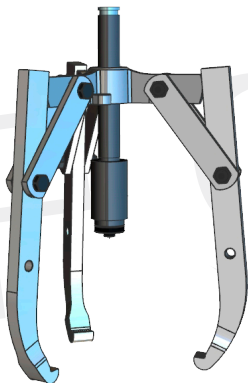

Thread the spindle to the body

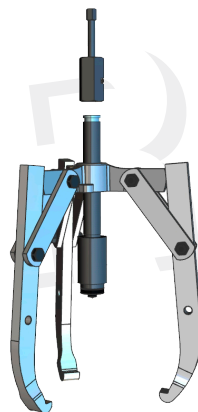

Thread the head to the spindle

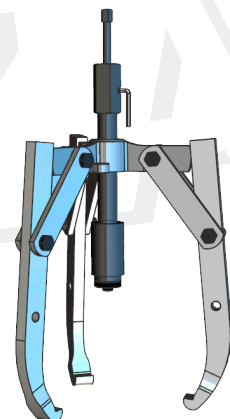

Tighten the M-8 prisoner

Instructions for use of 2400H pullers



Release the M-8 screw with a key



Unscrew the spindle head

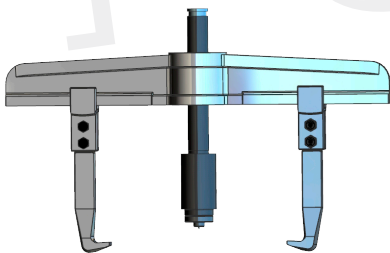

Thread the spindle to the body

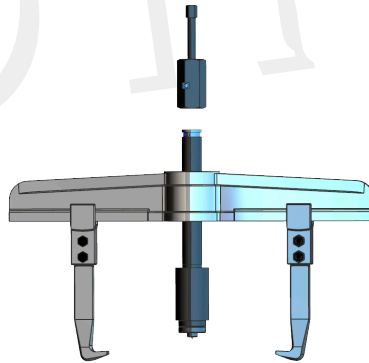

Thread the head to the spindle

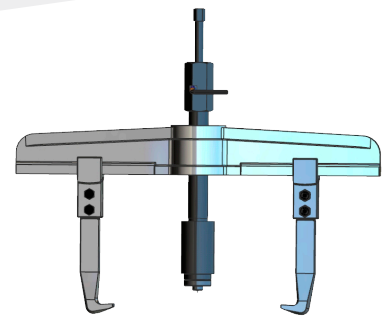

Tighten the M-8 prisoner

- 1- If the axis of the part is not centered use a point protector (2)
- 2- With the spindle fixed. Mount the puller in the part to be extracted. Make sure that it is centered (3)
- 3- Hand tighten the spindle until the tip is well supported on the shaft.
- 4- With a 17 wrench, pull the sub-spindle to apply force.
- 5- It is not advisable to use levers on the key when tightening the subspindle. With a 14 wrench is enough.
- 6- The return of the piston is manual
- 7- Lubricate (1) and do not hit (4) the spindle.

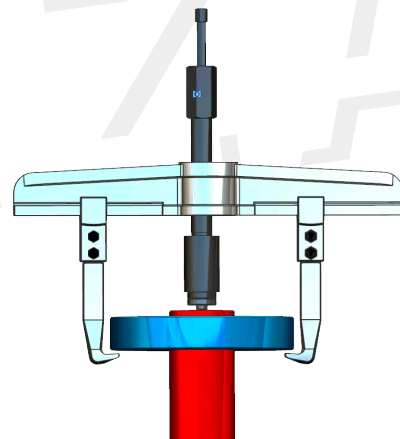
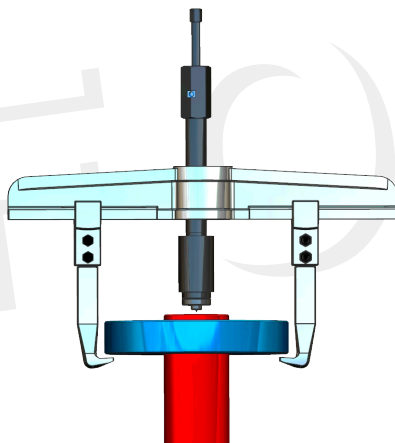



S.L. de Herramientas Especiales Forza

C/ San Miguel de Atxa, 24

01010 Vitoria

www.forza.es
