



Standart Seri Yassı Tip Tork Artırıcılar [170-6000 N.m]

Standard Mechanical Torque Multipliers [170-6000 N.m]



- » Torklama hassasiyeti $\pm 4\%$ daha iyi
- » **170 – 6000 N.m** aralığında 23 model
- » Aktarım oran seçenekleri 5:1 ~ 125:1
- » Tek ve çok kademeli planet dişli sistemi
- » sıkma ve sökme işlemlerine uygundur
- » Geniş çaplı, yassı tip, düşük tabanlı yapı
- » Kaydırmalı tip destek ayaklarıyla sevk edilir
- » Aktarımı yüksek modeller geri dönüş kilitlidir
- » Akredite kalibrasyonlu olarak sipariş verilebilir
- » Hafif ve ağır iş uygulamaları için uygun tasarım
- » Türkiye’de garanti servis ve yedek parça hizmeti

- » Accuracy guaranteed better than $\pm 4\%$,
- » 23 different models between 170-6000 N.m
- » 5:1 - 125:1 torque multiplication range
- » Single and multi-stage planet gear system
- » Suitable for clockwise and counter clockwise
- » Small, compact and aesthetics desing
- » High ratios allow the use of a small torque wrench
- » Robust construction, dont need maintenance
- » Anti Wind-Up Ratchet (AWUR) fitted to allow safer
- » Heavy duty is ideal for inclusion in the tool kit
- » UKAS accredited calibration may be ordered

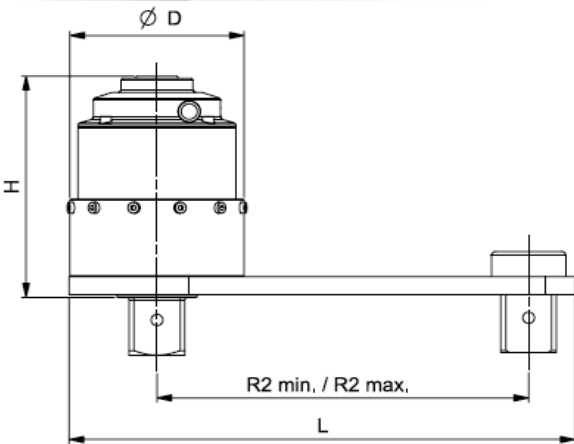

Gerİ Dönüş Yük Kilitli Standart Seri Yassı Mekanik Tork Artırıcılar

Standart Series Torque Multipliers-Non- Anti Wind Up Ratched

Parça Part	Tork Aralığı Torque Range		Oran Ratio	Giriş Kare Input Square		Çıkış Kare Output Square	Ağırlık Weight	Ölçüler (mm) Sizes			
	#	N.m		lbf.ft	#			inch	inch	H	L
16010	170-1700	125-1250	5:1	1/2"	3/4"	3.0	108	303	83	216	
16012.HD	170-1700	125-1250	5:1	3/4"	1"	3.2	108	303	83	216	
16034.HD	170-1700	125-1250	25:1	1/2"	1"	2.2	108	303	83	216	
16030	170-1700	125-1250	5:1	1/2"	1"	3.2	*	*	*	*	
16014	340-3400	250-2500	5:1	3/4"	1"	4.7	119	355	86	263	
16028	340-3400	250-2500	25:1	1/2"	1"	6.4	119	355	86	263	
16016	340-3400	250-2500	5:1	3/4"	1.1/2"	4.7	119	355	86	263	
16024	340-3400	250-2500	25:1	1/2"	1.1/2"	6.4	119	355	86	263	
16064.75	340-3400	250-2500	75:1	1/2"	1"	7.9	*	*	*	*	
16064	340-3400	250-2500	125:1	1/2"	1"	7.9	*	*	*	*	
16067	600-6000	450-4500	5:1	3/4"	1.1/2"	8.1	136	423	150	331	
16018	600-6000	450-4500	25:1	1/2"	1.1/2"	9.6	157	423	150	331	
16068.75	600-6000	450-4500	75:1	1/2"	1.1/2"	11.1	*	*	*	*	
16044	600-6000	450-4500	100:1	1/2" Hex	1.1/2"	11.6	*	*	*	*	

Gerİ Dönüş Yük Kilitli Standart Seri Yassı Mekanik Tork Artırıcılar

Standart Series Torque Multipliers-Anti Wind Up Ratched

Parça Part	Tork Aralığı Torque Range		Oran Ratio	Giriş Kare Input Square		Çıkış Kare Output Square	Ağırlık Weight	Ölçüler (mm) Sizes			
	#	N.m		lbf.ft	#			inch	inch	H	L
16088	170-1700	125-1250	25:1	1/2"	3/4"	5.5	*	*	*	*	
16089.HD	170-1700	125-1250	25:1	1/2"	1"	6.7	114	303	83	216	
16090	340-3400	250-2500	25:1	1/2"	1"	7.5	132	355	86	263	
16092	340-3400	250-2500	25:1	1/2"	1.1/2"	7.5	134	355	86	263	
16093	340-3400	250-2500	25:1	1/2"	1.1/2"	9.0	159	355	86	263	
16091	340-3400	250-2500	125:1	1/2"	1"	9.0	*	*	*	*	
16065	600-6000	450-4500	5:1	1/2"	1.1/2"	10.7	162	162	150	331	
16068	600-6000	450-4500	125:1	1/2"	1.1/2"	12.2	188	188	150	331	