

Air Pump

HYDRAULIC PA9 SERIES

148 cm³/min.
Single-Acting

Ideal for powering single-acting cylinders and portable hydraulic tools.

PUMPS

- Easier to operate than a hand pump, giving you the speed you need at an affordable price.
- Easy and economical to service; not a “throw away” unit.
- Unique bladder design for all-position operation and storage.
- Operates on 3-8 bar shop air, at 570 l.
- Hard-coat anodized aluminum housing.
- Oil filler with integral safety relief minimizes chance of damage to reservoir bladder if overfilling occurs.

PA9 Foot Control

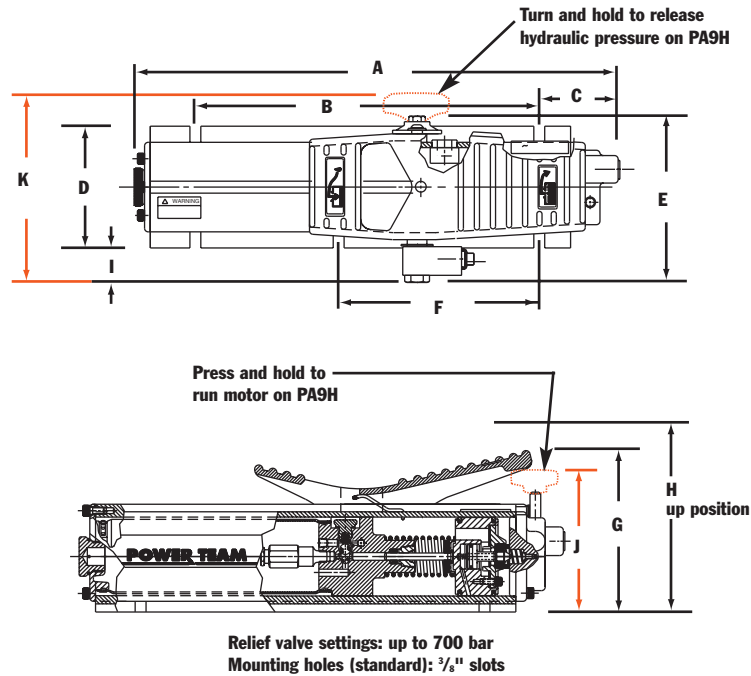

Pump No.	A (mm)	B (mm)	C (mm)	D (mm)	E (mm)	F (mm)	G (mm)	H (mm)	I (mm)	J (mm)	K (mm)
PA9	432	305	71,4	108	149	178	142	178	28,2	—	—
PA9H	432	305	71,4	108	—	178	—	178	28,2	122	170



PA9H Hand Control Pump as used in a straightening press.

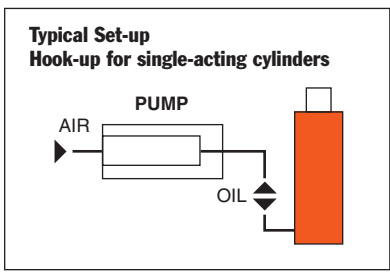
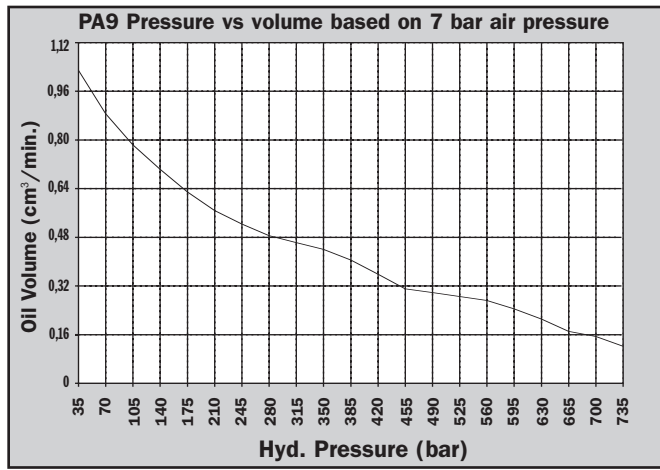

For Use with Cyl. Type	Order No.	Air Supply Req'd (bar)	Reservoir Cap. (cm ³)	Reservoir Usable (cm ³)	Oil Port (in)	Max. Pressure Output (bar)	Prod. Wt. (kg)
Single-Acting	PA9	3 – 8	574	549	³ / ₈ -NPTF	700	6,8
Single-Acting	PA9H	3 – 8	574	549	³ / ₈ -NPTF	700	6,8

