



Ultra Air Pump

UPF – Ultra Air Pump Foot

Air hydraulic pump, single acting, pedal operated, oil flow (l / min) 0,8 / 0,14 (1000bar) - 1,1 / 0,15 (l / min) to (700bar) - 2,1 / 0,2 (500bar) - 2,5 / 0,25 (400bar) - 2,6 / 0,7 (250bar)

Series: UP

Product line: Industrial tools, lifting systems, car repairers, clamping systems, hydraulic equipment (presses, jacks, ...), bead brakers, Automotive

- Pedal operation
- Unmistakable pedal design with integrated handle for portability
- 3-position pedal operation with spring return (advance, hold and release)
- Single-acting cylinder compatibility (double-acting with optional in-line hand valve)
- Compact and robust construction for heavy duty and long durability
- Easy maintenance
- No air lubricated required
- It works through the normal pneumatic network
- Versatile use in both vertical and horizontal positions
- Vent screw on the lid for tank ventilation during use
- Relief safety valve on the lid
- Maximum oil pressure valve adjustable from the outside to protect the circuit components
- Removable pyrex porthole level indicator for maximum easy refill
- Slots on the base support for easy installation onto the application
- Lightweight
- Low noise (75dBa)
- Various tank capacities (2.4 - 5 - 10 - 20) L for small and large cylinders

Technical features:

Max working pressure (bar):	250	400	500	700	1000
Cylinder compatibility:	Single acting Double acting through in-line hand valve (optional)				
Tank capacity (L):	2,4 – 5 – 7 – 10 – 12 – 20				
Usable oil (L):	2,1 – 4,65 – 6,9 – 9,5 – 11,1 – 19,4				
Max flow rate at nominal pressure (l/min):	0,7	0,25	0,2	0,15	0,14
Oil flow without load (l/min):	2,6	2,5	2,1	1,1	0,8
Oil flow with load (l/min):	0,7	0,25	0,2	0,15	0,14
Oil port:	3/8" NPTF (G3/8" – G1/4")				
Air port:	G1/4"				
Valve function:	Advance / Hold / Release				
Valve operation:	Manual				
Energy source:	Air				
Pneumatic range (bar):	2,8/8,3 (10 max)				
Average air consumption (l/min):	390		320	400	400
Noise (dBA):	75				
Weight (Kg):	6,8				

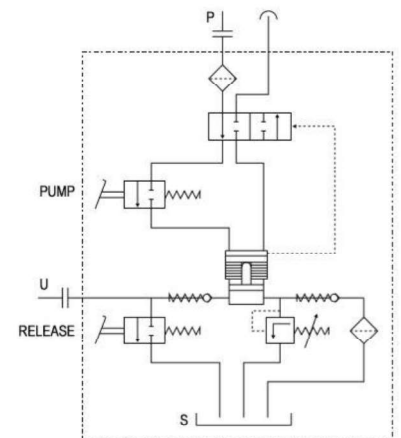

Size:

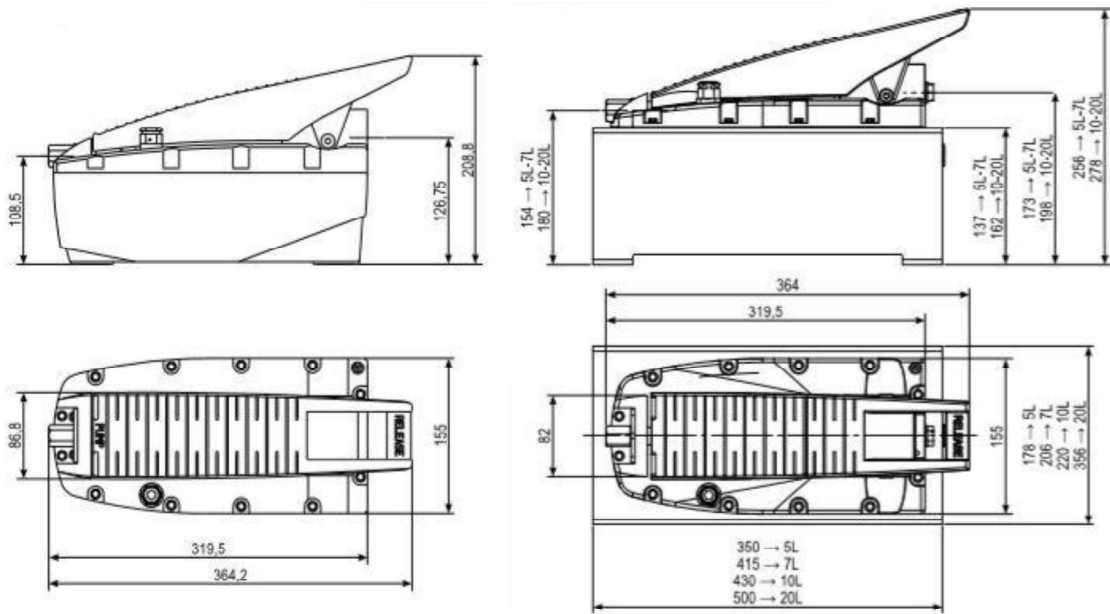

Series comparison:

Type	Max pressure (bar)	Cylinder	Tank (L)	Usable oil (L)	Oil flow unload (l/min)	Oil flow load (l/min)	Air range (bar)	Air consump (l/min)	Weight (kg)
UPF1002	1000	S.E.	2,4	2,1	0,8	0,14	2,8/10		6,8
UPF702	700	S.E.	2,4	2,1	1,1	0,15	2,8/10	50/440	6,5
UPF502	500	S.E.	2,4	2,1	2,1	0,2	2,8/10	110/320	6,8
UPF402	400	S.E.	2,4	2,1	2,5	0,25	2,8/10		6,7
UPF252	250	S.E.	2,4	2,1	2,6	0,7	2,8/10	180/390	6,7
UPF-2V702	700	S.E.	2,4	2,1	1,1	0,15	2,8/10	400	6,5
UPDPF705-16/5	700	S.E./2way	5	4,6	4,9	0,29	2,8/10		18
UPFD710	700	S.E.	10	9	8,5	0,26	4/10	780	23,7
UPFD725	700	S.E.	30	25	8,5	0,26	4/10	780	48,5

To order:

- P/N 915201100 UPF1002 1000BAR BELL
- P/N 915200010 UPF702 700BAR BELL
- P/N 915200030 UPF502 500BAR BELL
- P/N 91520098X UPF402 400BAR BELL
- P/N 915200020 UPF252 250BAR BELL

Accessories:

- Protection pedal kit
- Oversized tank
- Fixing plates
- Quick return kit (only for UPF)
- Fittings
- Hose Flex
- In-line hand valve for double acting cylinders
- Pressure gauge kit

Spare parts: SEAL KIT UPF