

Su Altı Saplama Gerdirme Cihazları

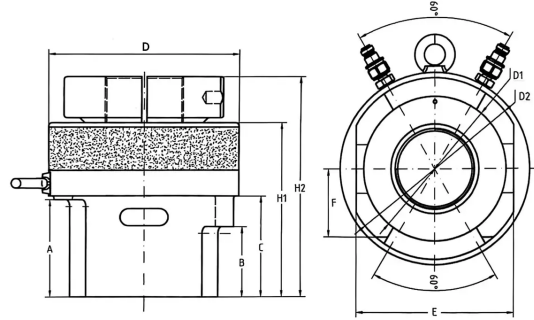

- » Kapasite 140 kN - 2400 kN
- » Kapasite aralığı M20 – M90
- » Imperial 3/4" - 3-1/2" inç
- » 7 farklı gerdirme pistonu
- » Çalışma basıncı 1500 bar
- » Her krikoda iki yağ girişi
- » Hızlı işlem için 30mm strok
- » Kilitli hızlı değişim somunu
- » Çift taraflı çalışma penceresi
- » Otomatik hizalama özelliği
- » Daha iyi tutuş için kaymaz yüzey
- » Tekli ve çoklu kullanıma uygun

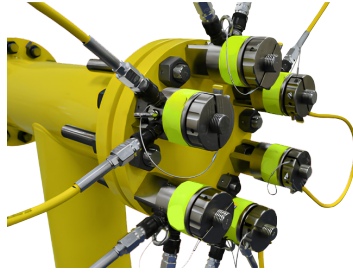

Model	Ölçü		Kuvvet	Strok	Hidrolik Etki Alanı		H2	H1	B	D	D1	D2	Min. Civata Boyu
	Metrik	Imp			kN	mm							
WST1	M20	3/4"	141	20	1.96	943	117	96	38	66	45	60	107
	M22	7/8"											105
WST2	M24	1" 1-1/8"	237	30	2.45	1585	147	127	51	82	56	75	139
	M27												136
	M30												134
WST3	M33	1-1/4" 1-3/8"	379	30	3.92	2532	162	137	58	97	67.5	92	142
	M36												139
WST4	M39	1-1/2" 1-5/8"	551	30	5.69	3676	169	145	63	111	80	106	147
	M42												144
WST5	M45	1-3/4" 1-7/8" 2"	880	30	9.10	5868	189	158	73	136	96	124	160
	M48												158
	M52												154
WST6	M56	2-1/4" 2-1/2" 2-3/4"	1564	30	16.17	10433	223	180	92	177	129	166	178
	M60												175
	M64												172
	M68												169
	M70												165
WST7	M76	3" 3-1/4" 3-1/2"	2419	30	26.63	16128	255	202	82	217	163	205	195
	M80												192
	M85												188
	M90												184



HLP3-20N



HLP3-20

1500 Bar
Hortum1500 Bar
Kaplın