

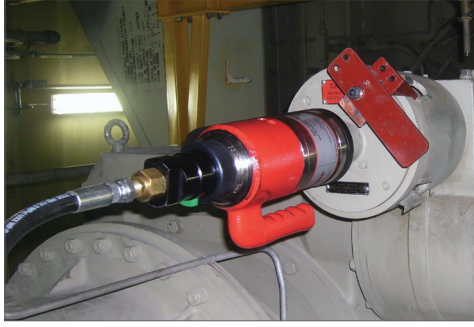

## Standart Seri Havalı Tork Artırıcılar - [160 - 3.400 N.m]

### Standard Series Pneumatic Torque Multipliers - [160 - 3.400 N.m]



- » Torklama hassasiyeti  $\pm 5\%$
- » **160 – 3400 N.m** aralığında 21 model
- » Sıkma ve sökme yönünde kullanılabilir
- » Tek veya çift hızlı şanzımanlı olarak sunulur
- » Boşta dönüş hız aralığı 5 – 150 devir / dakika
- » Darbesiz çalışır, 360° dönerek vidalama yapar
- » Tork sensörü ve açı ölçüm cihazı ile kullanılabilir
- » Sürgülü tip destek standart ayağı ile sevk edilir
- » Özel uygulamalar için farklı destek ayağı üretilir
- » Sıkma yönünde kalibrasyon belgesi mevcuttur
- » Her türlü endüstriyel torklama işlemine uygundur
- » Türkiye’de garanti servis ve yedek parça hizmeti

- » Accuracy better than  $\pm 5\%$
- » 21 models 160/3400 N.m
- » Suitable forward and reverse operation
- » Idle output speed range 5 - 150 rpm
- » Two speed and single speed models
- » Non-impacting or pulsing operation
- » Suitable for torque transducers & angle encoders
- » Supplied standert with a sliding reaction arm
- » Robust construction, longlife, maintenance free
- » Suitable models for almost every bolting application
- » Supplied with a house calibration certificate (CW)

#### Tek Hızlı Havalı Tork Artırıcılar / Single Speed Pneumatic Torque Multipliers

Parça Part	Tork Aralığı Torque Range		Sürücü Drive	Devir Hızı Idle Speed	Ağırlık Weight	Ölçüler (mm) Sizes			
#	N.m	lbf.ft	inch	d/d rpm	kg	H	L	R2 min	R2 max
16031	160-680	120-500	3/4"	30	10.6	350	303	83	216
16011	160-680	120-500	1"	30	10.6	350	303	83	216
16098	270-1200	200-900	3/4"	15	11.1	350	303	83	216
16097	270-1200	200-900	1"	15	11.1	350	303	83	216
16013	515-1700	380-1250	1"	9	11.1	350	303	83	216
16015	880-3400	650-2500	1"	5	14	393	355	86	263
16017	880-3400	650-2500	1.1/2"	5	14	393	355	86	263

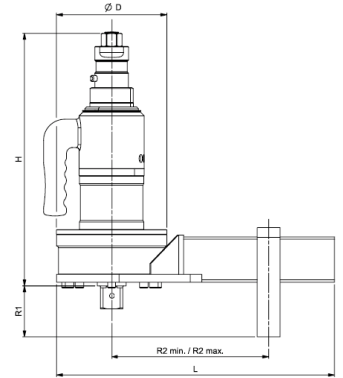

#### Çift Hızlı Havalı Tork Artırıcılar- [Otomatik] / Two Speed Automatic Torque Multipliers

Parça Part	Tork Aralığı Torque Range		Sürücü Drive	Devir Hızı Idle Speed	Ağırlık Weight	Ölçüler (mm) Sizes			
#	N.m	lbf.ft	inch	d/d rpm	kg	H	L	R2 min	R2 max
16031.AUT	160-680	120-500	3/4"	150	14.1	419	303	83	216
16011.AUT	160-680	120-500	1"	150	14.1	419	303	83	216
16098.AUT	270-1200	200-900	3/4"	75	14.6	419	303	83	216
16097.AUT	270-1200	200-900	1"	75	14.6	419	303	83	216
16013.AUT	515-1700	380-1250	1"	45	14.6	419	303	83	216
16015.AUT	880-3400	650-2500	1"	25	17.5	462	355	86	263
16017.AUT	880-3400	650-2500	1.1/2"	25	17.5	464	355	86	263



#### Çift Hızlı Havalı Tork Artırıcılar- [Manuel] / Two Speed Manual Torque Multipliers

Parça Part	Tork Aralığı Torque Range		Sürücü Drive	Devir Hızı Idle Speed	Ağırlık Weight	Ölçüler (mm) Sizes			
#	N.m	lbf.ft	inch	d/d rpm	kg	H	L	R2 min	R2 max
16031.MTS	160-680	120-500	3/4"	150	14.1	419	303	83	216
16011.MTS	160-680	120-500	1"	150	14.1	419	303	83	216
16098.MTS	270-1200	200-900	3/4"	75	14.6	419	303	83	216
16097.MTS	270-1200	200-900	1"	75	14.6	419	303	83	216
16013.MTS	515-1700	380-1250	1"	45	14.6	419	303	83	216
16015.MTS	880-3400	650-2500	1"	25	17.5	462	355	86	263
16017.MTS	880-3400	650-2500	1.1/2"	25	17.5	464	355	86	263

